

Table of Contents		
1	TITLE, TOC & REV	
2	MC33771	
3	SPI interface	

Revisions			
Rev	Description	Date	Approved
X1	Prototype initial	2020/3/17	Philippe Rousselle
A	Prototype release	2020/3/26	Philippe Rousselle

# FRDM33771CSPIEBV

## EVB MC33771C with SPI Interface

REF DES	ASSY_OPT	PAGE NAME
R41	DNP	02 - MC33771
J2_J1	DNP	03 - SPI interface

		<b>Automotive Product Group</b> 6501 William Cannon Drive West Austin, TX 78735-8598	
<small>This document contains information proprietary to NXP and shall not be used for engineering design, procurement or manufacture in whole or in part without the express written permission of NXP Semiconductors.</small>			
ICAP Classification: CP: _____ IUC: X PUE: _____			
Designer: Philippe Rousselle	Drawing Title: <b>XFRDM33771CSPEVB</b>		
Drawn by: Philippe Rousselle	Page Title: <b>TITLE, TOC &amp; REV</b>		
Approved: Philippe Rousselle	Size C	Document Number SCH-47189 PDF: SPF-47189	Rev A
Date: Monday, March 30, 2020	Sheet 1 of 3		



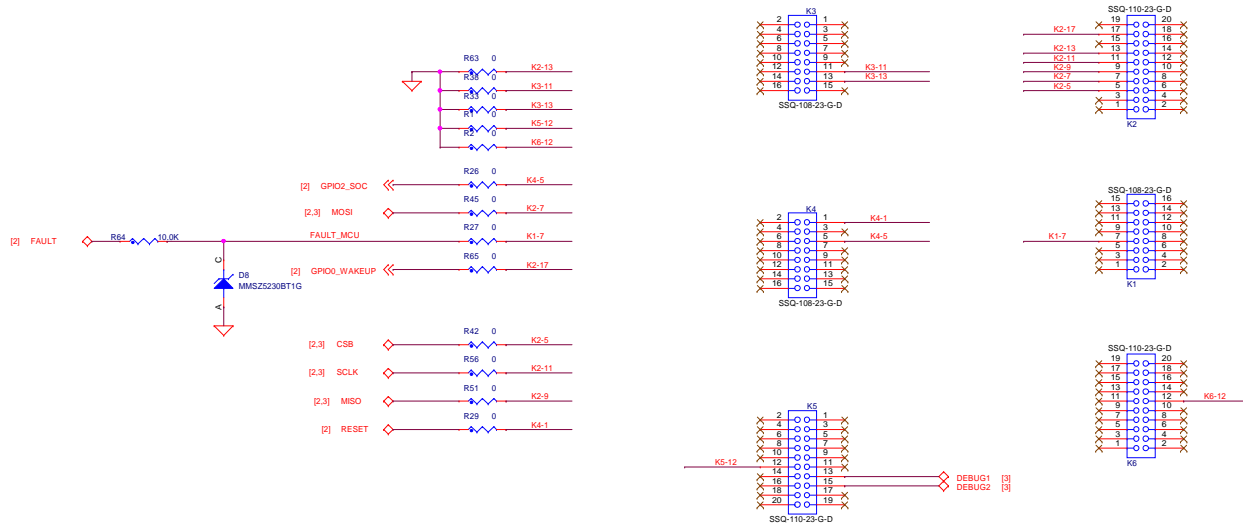

## SPI interface with S32K144EVb

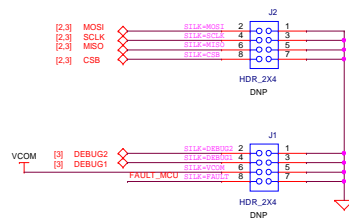

## SPI Analyzer Interface

ICAP Classification: <b>Classical</b>		UO: <b>PURR</b>
Drawing Title: <b>XFRDM33771CSPEVB</b>		
Page Title: <b>SPI Interface</b>		
Size: <b>C</b>	Document Number: <b>SCH-47189 PDF: SPP-47189</b>	Rev: <b>A</b>
Date: <b>Monday, March 30, 2020</b>	Sheet: <b>3</b>	of: <b>3</b>