

Motorola Embedded Motion Control

3-Phase ac BLDC High-Voltage Power Stage

User's Manual



MOTOROLA

**For More Information On This Product,
Go to: www.freescale.com**

Important Notice to Users

While every effort has been made to ensure the accuracy of all information in this document, Motorola assumes no liability to any party for any loss or damage caused by errors or omissions or by statements of any kind in this document, its updates, supplements, or special editions, whether such errors are omissions or statements resulting from negligence, accident, or any other cause. Motorola further assumes no liability arising out of the application or use of any information, product, or system described herein: nor any liability for incidental or consequential damages arising from the use of this document. Motorola disclaims all warranties regarding the information contained herein, whether expressed, implied, or statutory, *including implied warranties of merchantability or fitness for a particular purpose*. Motorola makes no representation that the interconnection of products in the manner described herein will not infringe on existing or future patent rights, nor do the descriptions contained herein imply the granting or license to make, use or sell equipment constructed in accordance with this description.

Trademarks

This document includes these trademarks:

Motorola and the Motorola logo are registered trademarks of Motorola, Inc.

Motorola, Inc., is an Equal Opportunity / Affirmative Action Employer.



List of Sections

Section 1. Introduction and Setup	11
Section 2. Operational Description	19
Section 3. Pin Descriptions	25
Section 4. Schematics and Parts List	31
Section 5. Design Considerations	47



Table of Contents

Section 1. Introduction and Setup

1.1	Contents	11
1.2	Introduction.....	11
1.3	About this Manual.....	13
1.4	Warnings.....	15
1.5	Setup Guide.....	16

Section 2. Operational Description

2.1	Contents	19
2.2	Description	19
2.3	Electrical Characteristics	21
2.4	Modification for One-Half and Three-Fourths Horsepower.....	22
2.5	Fuse Replacement.....	23

Section 3. Pin Descriptions

3.1	Contents	25
3.2	Pin-by-Pin Descriptions	25
3.2.1	Power Input Connector J11	25
3.2.2	Motor Output Connector J13	26
3.2.3	External Brake Connector J12	26
3.2.4	40-Pin Ribbon Connector J14	27

Section 4. Schematics and Parts List

4.1 Contents 31

4.2 Mechanical Characteristics 31

4.3 Schematics 31

4.4 Parts Lists 40

Section 5. Design Considerations

5.1 Contents 47

5.2 Overview 47

5.3 3-Phase H-Bridge 48

5.4 Bus Voltage and Current Feedback 50

5.5 Cycle-by-Cycle Current Limiting 52

5.6 Temperature Sensing 54

5.7 Back EMF Signals 55

5.8 Phase Current Sensing 56

5.9 Brake 57

5.10 Power Factor Correction 58

List of Figures

Figure	Title	Page
1-1	Systems' Configurations	13
1-2	3-Phase ac BLDC High-Voltage Power Stage	14
1-3	Setup	17
1-4	PFC Jumper.	18
2-1	Block Diagram	20
3-1	40-Pin Ribbon Connector J14.	27
4-1	3-Phase ac BLDC High-Voltage Power Stage Overview.	32
4-2	Gate Drive.	33
4-3	3-Phase H-Bridge	34
4-4	Current and Temperature Feedback	35
4-5	Back EMF Signals	36
4-6	Power Factor Correction and Brake Gate Drives	37
4-7	Power Supply	38
4-8	Identification Block	39
5-1	Phase A Output	49
5-2	Bus Feedback	51
5-3	Cycle-by-Cycle Current Limiting.	53
5-4	Temperature Sensing	54
5-5	Phase A Back EMF.	55
5-6	Phase A Current Sensing	56
5-7	Brake.	58
5-8	PFC Circuitry	59
5-9	PFC Zero Crossing Feedback	60



List of Figures

Freescale Semiconductor, Inc.

List of Tables

Table	Title	Page
2-1	Electrical Characteristics	21
2-2	Resistor Values	22
2-3	JP801 Settings	22
2-4	Fuse Ratings	23
3-1	Connector J13 Signal Descriptions	26
3-2	Connector J14 Signal Descriptions	28
4-1	Power Substrate Parts List	40
4-2	Printed Circuit Board Parts List	41



Section 1. Introduction and Setup

1.1 Contents

1.2	Introduction.	11
1.3	About this Manual.	13
1.4	Warnings.	15
1.5	Setup Guide.	16

1.2 Introduction

Motorola's 3-Phase ac high-voltage brushless dc (BLDC) power stage (HV ac power stage) is a 115/230 volt, 180 watt (one-fourth horsepower), off-line power stage that is an integral part of Motorola's embedded motion control series of development tools. It is supplied in kit number ECPWRHiVACBLDC.

In combination with one of the embedded motion control series control boards and an embedded motion control series optoisolation board, it provides a ready-made software development platform for fractional horsepower off-line motors. Feedback signals are provided that allow 3-phase ac induction and BLDC motors to be controlled with a wide variety of algorithms. In addition, the HV ac power stage includes an active power factor correction (PFC) circuit that facilitates development of PFC algorithms.

An illustration of the systems' architecture is shown in [Figure 1-1](#). A line drawing appears in [Figure 1-2](#).

The HV ac power stage's features are:

- 1-phase bridge rectifier
- Power factor switch and diode
- dc-bus brake IGBT and brake resistors
- 3-phase bridge inverter (6-IGBT's)
- Individual phase and dc bus current sensing shunts with Kelvin connections
- Power stage temperature sensing diodes
- IGBT gate drivers
- Current and temperature signal conditioning
- 3-phase back-EMF voltage sensing and zero cross detection circuitry
- Board identification processor (MC68HC705JJ7)
- Low-voltage on-board power supplies
- Cooling fans

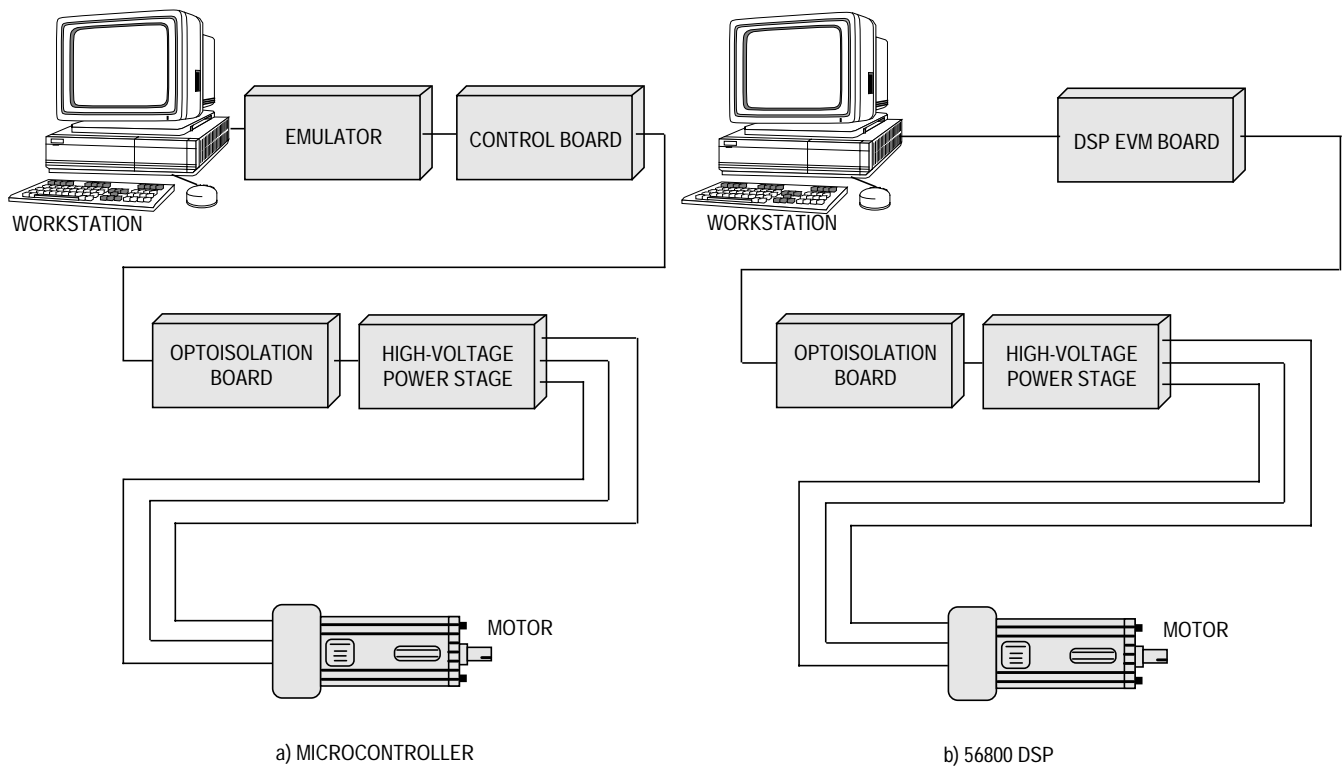

Figure 1-1. Systems' Configurations

1.3 About this Manual

Key items can be found in the following locations in this manual:

- Setup instructions are found in [1.5 Setup Guide](#).
- Schematics are found in [Section 4. Schematics and Parts List](#).
- Pin assignments are shown in [Figure 3-1. 40-Pin Ribbon Connector J14](#), and a pin-by-pin description is contained in [3.2 Pin-by-Pin Descriptions](#).
- For those interested in the reference design aspects of the board's circuitry, a description is provided in [Section 5. Design Considerations](#).

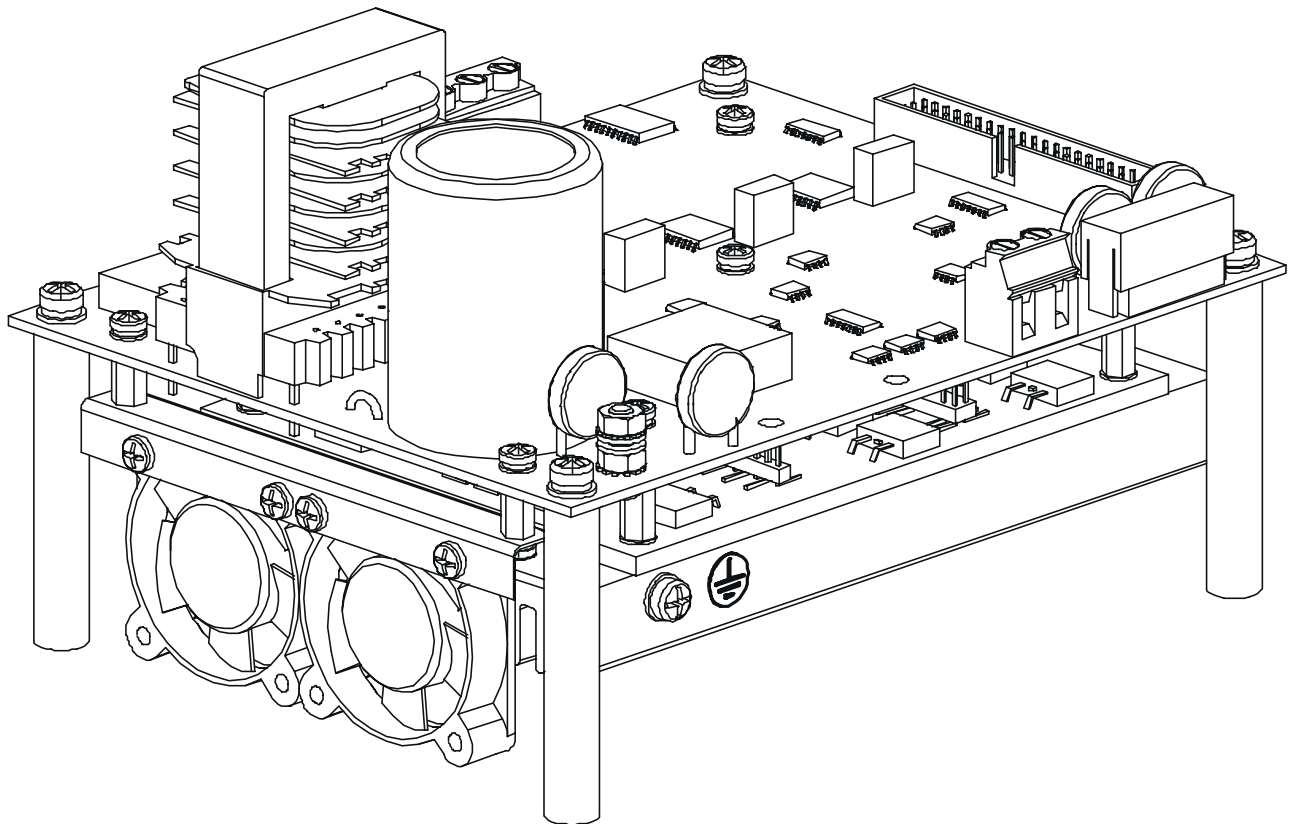

Figure 1-2. 3 Phase AC BLDC High Voltage Power Stage

1.4 Warnings

This development tool set operates in an environment that includes dangerous voltages and rotating machinery.

To facilitate safe operation, input power for the HV ac power stage should come from a current limited dc laboratory power supply, unless power factor correction is specifically being investigated.

An isolation transformer should be used when operating off an ac power line.

If an isolation transformer is not used, power stage grounds and oscilloscope grounds are at different potentials, unless the oscilloscope is floating. Note that probe grounds and, therefore, the case of a floated oscilloscope are subjected to dangerous voltages.

The user should be aware that:

- Before moving scope probes, making connections, etc., it is generally advisable to power down the high-voltage supply.
- When high voltage is applied, using only one hand for operating the test setup minimizes the possibility of electrical shock.
- Operation in lab setups that have grounded tables and/or chairs should be avoided.
- Wearing safety glasses, avoiding ties and jewelry, using shields, and operation by personnel trained in high-voltage lab techniques are also advisable.
- Power transistors, the PFC coil, and the motor can reach temperatures hot enough to cause burns.
- When powering down; due to storage in the bus capacitors, dangerous voltages are present until the power-on LED is off.

1.5 Setup Guide

Setup and connections for the HV ac power stage are straightforward. The power stage connects to an embedded motion control optoisolation board via a 40-pin ribbon cable and can be powered either by a 140- to 230-volt dc power supply or with line voltage. For both safety reasons and ease of making measurements, it is strongly recommended that a dc supply is used, unless power factor correction is specifically being investigated. The power supply should be current limited to under 4 amps. **Figure 1-3** depicts a completed setup. A step-by-step setup procedure is:

1. Plug one end of the 40-pin ribbon cable that comes with the optoisolator kit into input connector J14. The other end of this cable goes to the optoisolation board's 40-pin output connector.
2. Connect motor leads to output connector J13, located along the back edge of the top board. Phase A, phase B, and phase C are labeled Ph_A, Ph_B, and Ph_C.

For an ac induction motor, it does not matter which lead goes to which phase. For BLDC motors, it is important to get the wire color coded for phase A into the connector terminal labeled Ph_A, and so on for phase B and phase C.

3. Connect earth ground to the earth ground terminals on the top board and on the heat sink. The top board's ground terminal is located in the front left-hand corner and is marked with a ground symbol. The heat sink has a screw on its front edge that is also marked with a ground symbol.
4. Connect a line isolated, current limited dc power supply to connector J11, located on the front edge of the top board. The input voltage range is 140 to 230 Vdc. Current limit should be set for less than 4 amps. The dc supply's polarity does not matter.

Either a 110-volt or 220-volt ac line that is coupled through an isolation transformer may be used in place of a dc supply to provide input power. The connection is made on connector J11. Bias voltages are developed by internal power supplies. Only one power input is required.

WARNING: *Operation off an ac power line is significantly more hazardous than operation from a line isolated and current limited dc power supply.*

An isolation transformer should be used when operating off an ac power line.

5. Set up the optoisolation and control boards.
6. Optional PFC — The HV ac power stage is shipped with power factor correction (PFC) disabled. If power factor correction is desired, it is necessary to remove and resolder power jumper JP201 from the no PFC position to the PFC position. This jumper is found on the left side of the top board between the dc bus capacitor and PFC inductor. Circuit connections are illustrated in [Figure 1-4](#). For first time setups, operation without power factor correction is recommended.
7. Apply power first to the optoisolator and then to the power stage. The green power-on LED in the upper right-hand corner lights, and both fans run when power is present. Note that the optoisolation board powers the control board, and that the optoisolation board is not fully powered until power is applied to the power stage.

CAUTION: *Hazardous voltages are present. Re-read all of 1.4 Warnings carefully.*

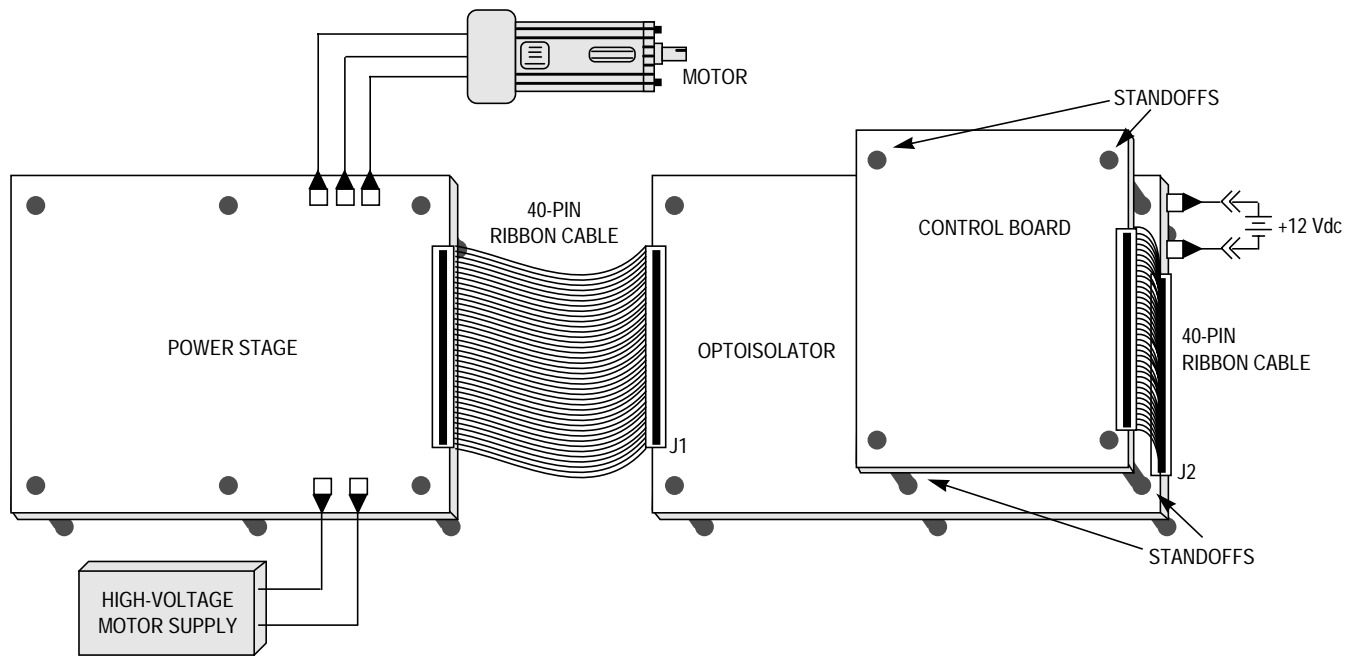

Figure 1-3. Setup

Introduction and Setup

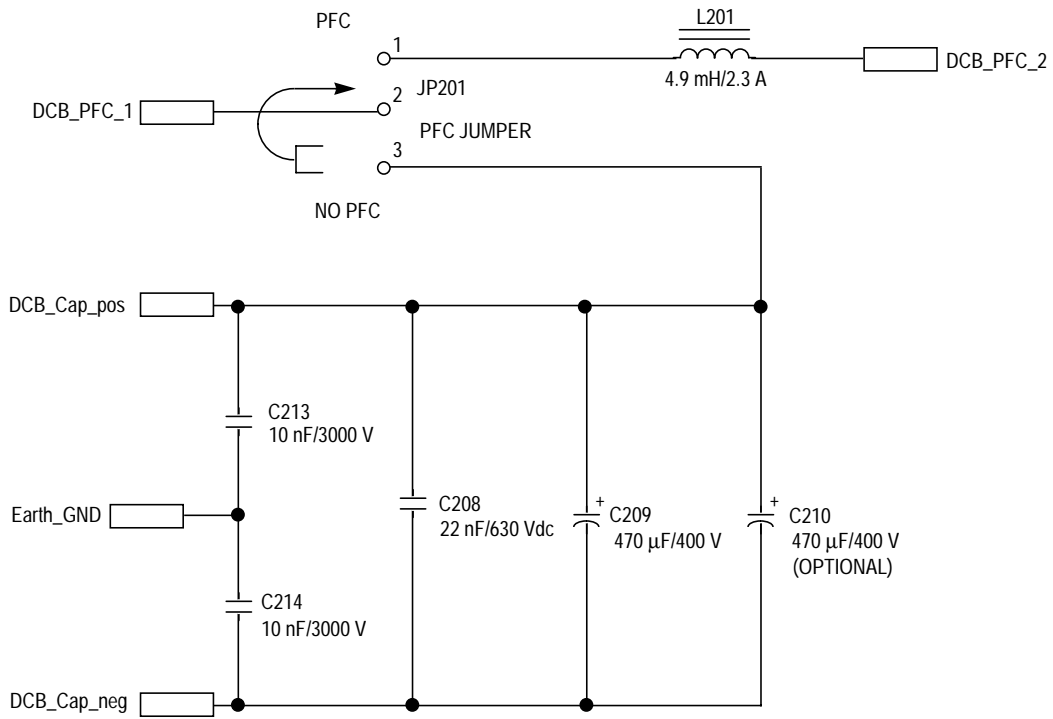

Figure 1-4. PFC Jumper

Section 2. Operational Description

2.1 Contents

2.2	Description	19
2.3	Electrical Characteristics	21
2.4	Modification for One-Half and Three-Fourths Horsepower.	22
2.5	Fuse Replacement	23

2.2 Description

Motorola's embedded motion control series high-voltage (HV) ac power stage is a 180 watt (one-fourth horsepower), 3-phase power stage that will operate off of dc input voltages from 140 to 230 volts and ac line voltages from 100 to 240 volts. In combination with one of the embedded motion control series control boards and an optoisolation board, it provides a software development platform that allows algorithms to be written and tested without the need to design and build a power stage. It supports a wide variety of algorithms for both ac induction and brushless dc (BLDC) motors.

Input connections are made via 40-pin ribbon cable connector J14. Pin assignments for the input connector are shown in **Figure 3-1. 40-Pin Ribbon Connector J14**. Power connections to the motor are made on output connector J13. Phase A, phase B, and phase C are labeled PH_A, Ph_B, and Ph_C on the board. Power requirements are met with a single external 140- to 230-volt dc power supply or an ac line voltage. Either input is supplied through connector J11. Current measuring circuitry is set up for 2.93 amps full scale. Both bus and phase leg currents are measured. A cycle-by-cycle overcurrent trip point is set at 2.69 amps.

Operational Description

The high-voltage ac power stage has both a printed circuit board and a power substrate. The printed circuit board contains IGBT gate drive circuits, analog signal conditioning, low-voltage power supplies, power factor control circuitry, and some of the large, passive, power components. This board also has an MC68HC705JJ7 microcontroller that is used for configuration and identification. All of the power electronics which need to dissipate heat are mounted on the power substrate. This substrate includes the power IGBTs, brake resistors, current sensing resistors, a power factor correction MOSFET, and temperature sensing diodes. **Figure 2-1** shows a block diagram.

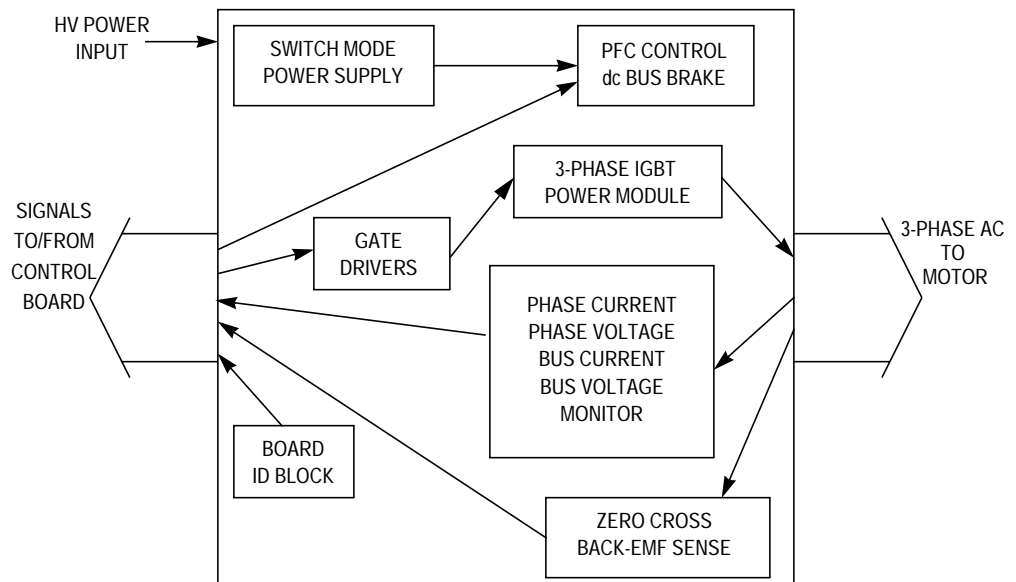

Figure 2-1. Block Diagram

2.3 Electrical Characteristics

The electrical characteristics in [Table 2-1](#) apply to operation at 25°C with a 160-Vdc power supply voltage.

Table 2-1. Electrical Characteristics

Characteristic	Symbol	Min	Typ	Max	Units
dc input voltage	V _{dc}	140	160	230	V
ac input voltage	V _{ac}	100	208	240	V
Quiescent current	I _{CC}	—	70	—	mA
Min logic 1 input voltage	V _{IH}	2.0	—	—	V
Max logic 0 input voltage	V _{IL}	—	—	0.8	V
Input resistance	R _{In}	—	10 kΩ	—	
Analog output range	V _{Out}	0	—	3.3	V
Bus current sense voltage	I _{Sense}	—	563	—	mV/A
Bus voltage sense voltage	V _{Bus}	—	8.09	—	mV/V
Peak output current	I _{PK}	—	—	2.8	A
Brake resistor dissipation (continuous)	P _{BK}	—	—	50	W
Brake resistor dissipation (15 sec pk)	P _{BK(Pk)}	—	—	100	W
Total power dissipation	P _{diss}	—	—	85	W

2.4 Modification for One-Half and Three-Fourths Horsepower

The HV ac power stage can be modified for operation at either one-half or three-fourths horsepower. To change maximum output power, follow these steps:

1. Remove power and wait until the power-on LED is off.
2. If PFC jumper JP201 is in the PFC position, remove and resolder it into the no PFC position.
3. Make the resistor value changes shown in **Table 2-2**. These resistors set current amplifier gains. For one-half and three-fourths horsepower, lower gains allow for higher measured currents and higher overcurrent trip points.

Table 2-2. Resistor Values

Resistors	1/4 HP (180 W)	1/2 HP (370 W)	3/4 HP (550 W)
R303, R305, R307, R314, R315, R318, R319, R322	75 kΩ	62 kΩ	56 kΩ
R301, R304, R311, R313, R316, R317, R320, R321	10 kΩ	15 kΩ	16 kΩ

4. Configure identification coding jumper JP801 with the settings indicated in **Table 2-3**. This procedure allows software to interpret the new analog values correctly.

Table 2-3. JP801 Settings

Position	1/4 HP (180 W)	1/2 HP (370 W)	3/4 HP (550 W)
1-2	Open	Short	Open
3-4	Open	Open	Short
5-6	Open	Open	Open
7-8	Open	Open	Open

5. For 550 watts (three-fourths horsepower), it is also necessary to add an additional 470- μ F/400-volt bus capacitor. To install the capacitor, it is first necessary to remove PFC inductor L201. Mounting holes for the additional capacitor are located within L201's footprint. Note that it is essential to orient the capacitor such that polarity is correct. Positive and negative connections are indicated by + (plus) and - (minus) silk-screened labels on the board. In addition, the pad for the capacitor's positive lead is square, and the pad for its negative lead is round.
6. Once these changes have been made, configuration for either one-half or three-fourths horsepower is complete.

2.5 Fuse Replacement

A fast blow fuse is located on the front right-hand corner of the top board. If this fuse has to be replaced, follow these steps:

1. Remove power and wait until the power-on LED is off.
2. Remove the fuse's protective case.
3. Replace the fuse with one of the selections shown in [Table 2-4](#).

Table 2-4. Fuse Ratings

Motor Horsepower	RMS Input Current (Amps)	Fuse Current Rating (Amps)	Fuse Voltage Rating (Volts)	Fuse Type
$\frac{1}{4}$ (180 W)	2.3	2.5	250	Fast blow
$\frac{1}{2}$ (370 W)	4.8	6.3	250	Fast blow
$\frac{3}{4}$ (550 W)	7.1	8	250	Fast blow

4. Replace the protective case.
5. Set the controller's speed control input to zero RPM.
6. Apply power and resume operation.



Section 3. Pin Descriptions

3.1 Contents

3.2	Pin-by-Pin Descriptions	25
3.2.1	Power Input Connector J11	25
3.2.2	Motor Output Connector J13	26
3.2.3	External Brake Connector J12	26
3.2.4	40-Pin Ribbon Connector J14	27

3.2 Pin-by-Pin Descriptions

Inputs and outputs are located on four connectors. Pin descriptions for each of these connectors are included in this section.

3.2.1 Power Input Connector J11

The power input connector, labeled J11, is located on the front edge of the board. It will accept dc voltages from 140 to 230 volts or an isolated ac line input from 100 to 240 volts. In either case, the power source should be capable of supplying at least 200 watts.

Pin Descriptions

3.2.2 Motor Output Connector J13

Power outputs to the motor are located on connector J11. Phase outputs are labeled Ph_A, Ph_B, and Ph_C. Pin assignments are described in [Table 3-1](#).

Table 3-1. Connector J13 Signal Descriptions

Pin No.	Signal Name	Description
1	Ph_A	Ph_A supplies power to motor phase A. On an induction motor, any one of the three phase windings can be connected here. For brushless dc motors it is important to connect the wire color coded for phase A into the connector terminal labeled Ph_A, and so on for phase B and phase C.
2	Ph_B	Ph_B supplies power to motor phase B. On an induction motor, any one of the three phase windings can be connected here. For brushless dc motors it is important to connect the wire color coded for phase B into the connector terminal labeled Ph_B, and so on for phase A and phase C.
3	Ph_C	Ph_C supplies power to motor phase C. On an induction motor, any one of the three phase windings can be connected here. For brushless dc motors it is important to connect the wire color coded for phase C into the connector terminal labeled Ph_C, and so on for phase A and phase B.

3.2.3 External Brake Connector J12

An optional external brake resistor can be connected to external brake connector J12, labeled Ext. Brake. The external resistor allows power dissipation to increase beyond the 50 watts that brake resistors R6–R9 provide.

3.2.4 40-Pin Ribbon Connector J14

Signal inputs are grouped together on 40-pin ribbon cable connector J14, located on the right side of the board. Pin assignments are shown in **Figure 3-1**. In this figure, a schematic representation appears on the left, and a physical layout of the connector appears on the right. The physical view assumes that the board is oriented such that its title is read from left to right. Signal descriptions are listed in **Table 3-2**.

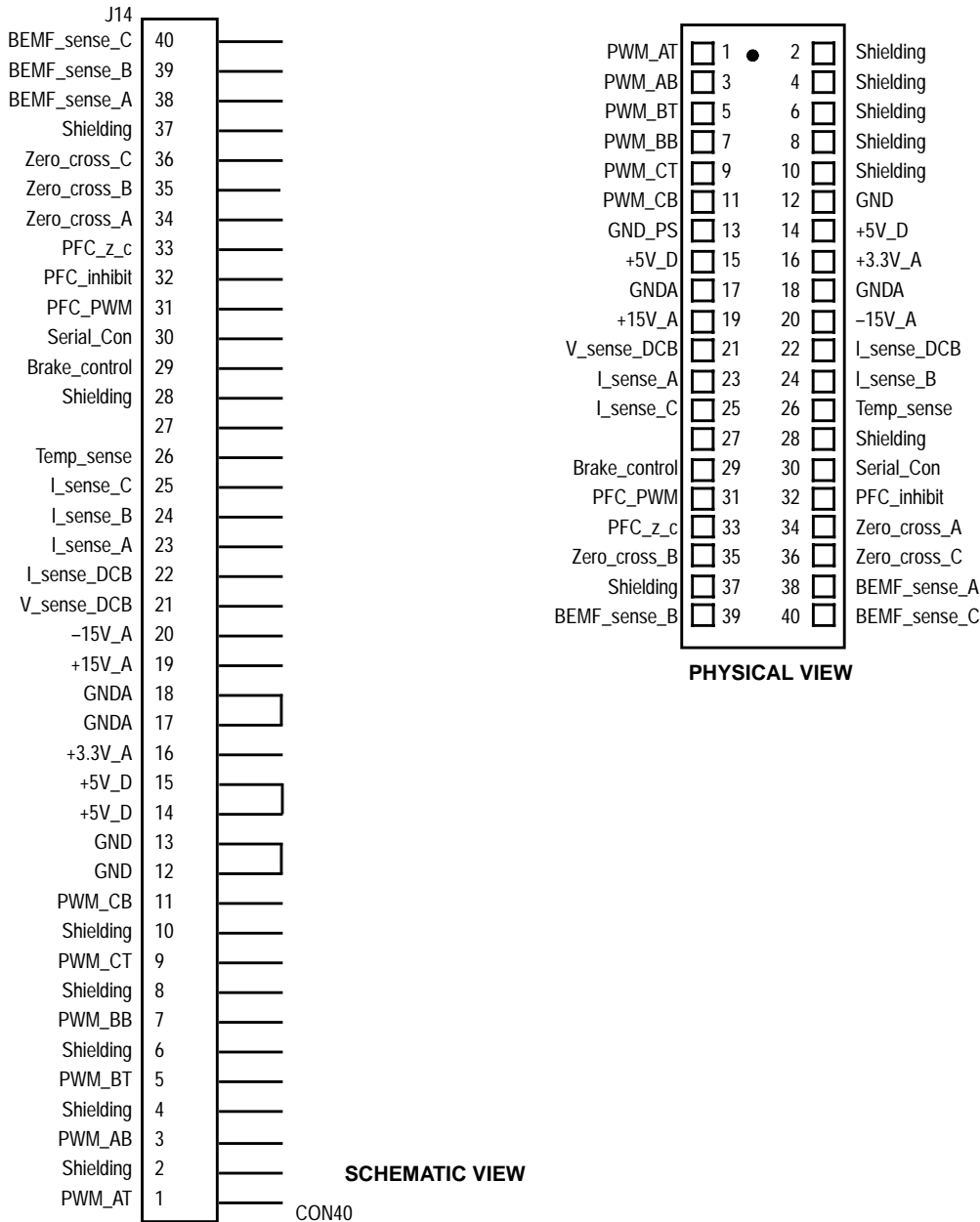

Figure 3-1. 40-Pin Ribbon Connector J14

Table 3-2. Connector J14 Signal Descriptions

Pin No.	Signal Name	Description
1	PWM_AT	PWM_AT is the gate drive signal for the top half-bridge of phase A. A logic high turns phase A's top switch on.
2	Shielding	Pin 2 is connected to a shield wire in the ribbon cable and ground on the board.
3	PWM_AB	PWM_AB is the gate drive signal for the bottom half-bridge of phase A. A logic high turns phase A's bottom switch on.
4	Shielding	Pin 4 is connected to a shield wire in the ribbon cable and ground on the board.
5	PWM_BT	PWM_BT is the gate drive signal for the top half-bridge of phase B. A logic high turns phase B's top switch on.
6	Shielding	Pin 6 is connected to a shield wire in the ribbon cable and ground on the board.
7	PWM_BB	PWM_BB is the gate drive signal for the bottom half-bridge of phase B. A logic high turns phase B's bottom switch on.
8	Shielding	Pin 8 is connected to a shield wire in the ribbon cable and ground on the board.
9	PWM_CT	PWM_CT is the gate drive signal for the top half-bridge of phase C. A logic high turns phase C's top switch on.
10	Shielding	Pin 10 is connected to a shield wire in the ribbon cable and ground on the board.
11	PWM_CB	PWM_CB is the gate drive signal for the bottom half-bridge of phase C. A logic high turns phase C's bottom switch on.
12	GND	Digital and power ground
13	GND	Digital and power ground, redundant connection
14	+5V digital	Digital +5-volt power supply
15	+5V digital	Digital +5-volt power supply, redundant connection
16	+3.3V analog	Analog +3.3-volt power supply
17	GND_A	Analog power supply ground
18	GND_A	Analog power supply ground, redundant connection
19	+15V_A	Analog +15-volt power supply
20	-15V_A	Analog -15-volt power supply
21	V_sense_DCB	V_sense_DCB is an analog sense signal that measures dc bus voltage. It is scaled at 8.09 mV per volt of dc bus voltage.
22	I_sense_DCB	I_sense_DCB is an analog sense signal that measures dc bus current. It is scaled at 0.563 volts per amp of dc bus current.

Table 3-2. Connector J14 Signal Descriptions (Continued)

Pin No.	Signal Name	Description
23	I_sense_A	I_sense_A is an analog sense signal that measures current in phase A. It is scaled at 0.563 volts per amp of dc bus current.
24	I_sense_B	I_sense_B is an analog sense signal that measures current in phase B. It is scaled at 0.563 volts per amp of dc bus current.
25	I_sense_C	I_sense_C is an analog sense signal that measures current in phase C. It is scaled at 0.563 volts per amp of dc bus current.
26	Temp_sense	Temp_sense is an analog sense signal that measures power module temperature.
27		No connection
28	Shielding	Pin 28 is connected to a shield wire in the ribbon cable and analog ground on the board.
29	Brake_control	Brake_control is the gate drive signal for the brake IGBT.
30	Serial_Con	Serial_Con is an identification signal that lets the controller know which power stage is present.
31	PFC_PWM	PFC_PWM is a digital signal that controls the power factor correction circuit's switch.
32	PFC_inhibit	PFC_inhibit is a digital output used to enable or disable the power factor correction circuit.
33	PFC_z_c	PFC_z_c is a digital signal. Its edges represent power line voltage zero crossing events.
34	Zero_cross_A	Zero_cross_A is a digital signal used for sensing phase A back-EMF zero crossing events.
35	Zero_cross_B	Zero_cross_B is a digital signal used for sensing phase B back-EMF zero crossing events.
36	Zero_cross_C	Zero_cross_C is a digital signal used for sensing phase C back-EMF zero crossing events.
37	Shielding	Pin 37 is connected to a shield wire in the ribbon cable and analog ground on the board.
38	BEMF_sense_A	BEMF_sense_A is an analog sense signal that measures phase A back EMF. It is scaled at 8.09 mV per volt of dc bus voltage.
39	BEMF_sense_B	BEMF_sense_B is an analog sense signal that measures phase B back EMF. It is scaled at 8.09 mV per volt of dc bus voltage.
40	BEMF_sense_C	BEMF_sense_A is an analog sense signal that measures phase C back EMF. It is scaled at 8.09 mV per volt of dc bus voltage.



Section 4. Schematics and Parts List

4.1 Contents

4.2	Mechanical Characteristics	31
4.3	Schematics	31
4.4	Parts Lists	40

4.2 Mechanical Characteristics

Mechanically, the high-voltage (HV) power stage consists of an FR-4 circuit board, a 3.2-mm aluminum circuit board, two fans, a fan bracket, a heat sink, inter-board connectors, and standoffs. Construction is depicted in **Figure 1-2. 3-Phase ac BLDC High-Voltage Power Stage**. The aluminum circuit board, fans, and heat sink provide thermal capability for surface-mounted power components. The FR-4 board contains control circuitry and through-hole mounted power components. The two boards plug together via 10 vertical connectors to, in effect, form a discrete power module.

Four holes on the top board are spaced to allow mounting standoffs such that a control board can be placed on top of the power stage. This configuration allows mounting control and power functions in one compact mechanical assembly.

4.3 Schematics

A set of schematics for the HV ac power stage appears in **Figure 4-1** through **Figure 4-8**. An overview of the board appears in **Figure 4-1**. H-bridge gate drive is shown in **Figure 4-2**. The 3-phase H-bridge appears in **Figure 4-3**. Current and temperature feedback circuits are shown in **Figure 4-4**. Back EMF feedback circuitry appears in **Figure 4-5**. Power factor correction and brake gate drives are shown in **Figure 4-6**. An on-board power supply appears in **Figure 4-7**, and finally the identification block is shown in **Figure 4-8**. Unless otherwise specified, resistors are 1/8 watt, have a $\pm 5\%$ tolerance, and have values shown in ohms. Interrupted lines coded with the same letters are electrically connected.

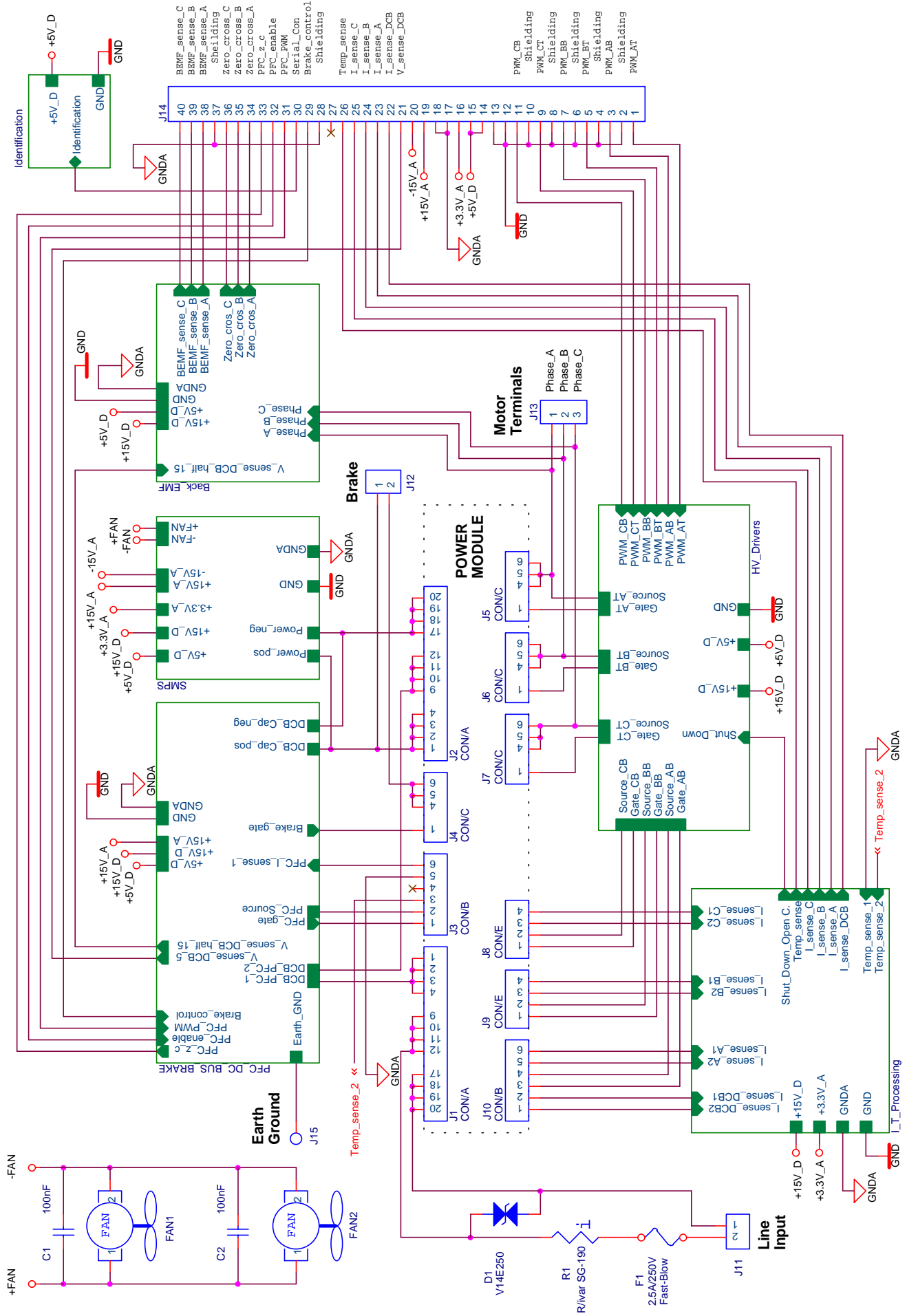

Figure 4-1. 3 Phase AC BLDC High Voltage Power Stage Overview

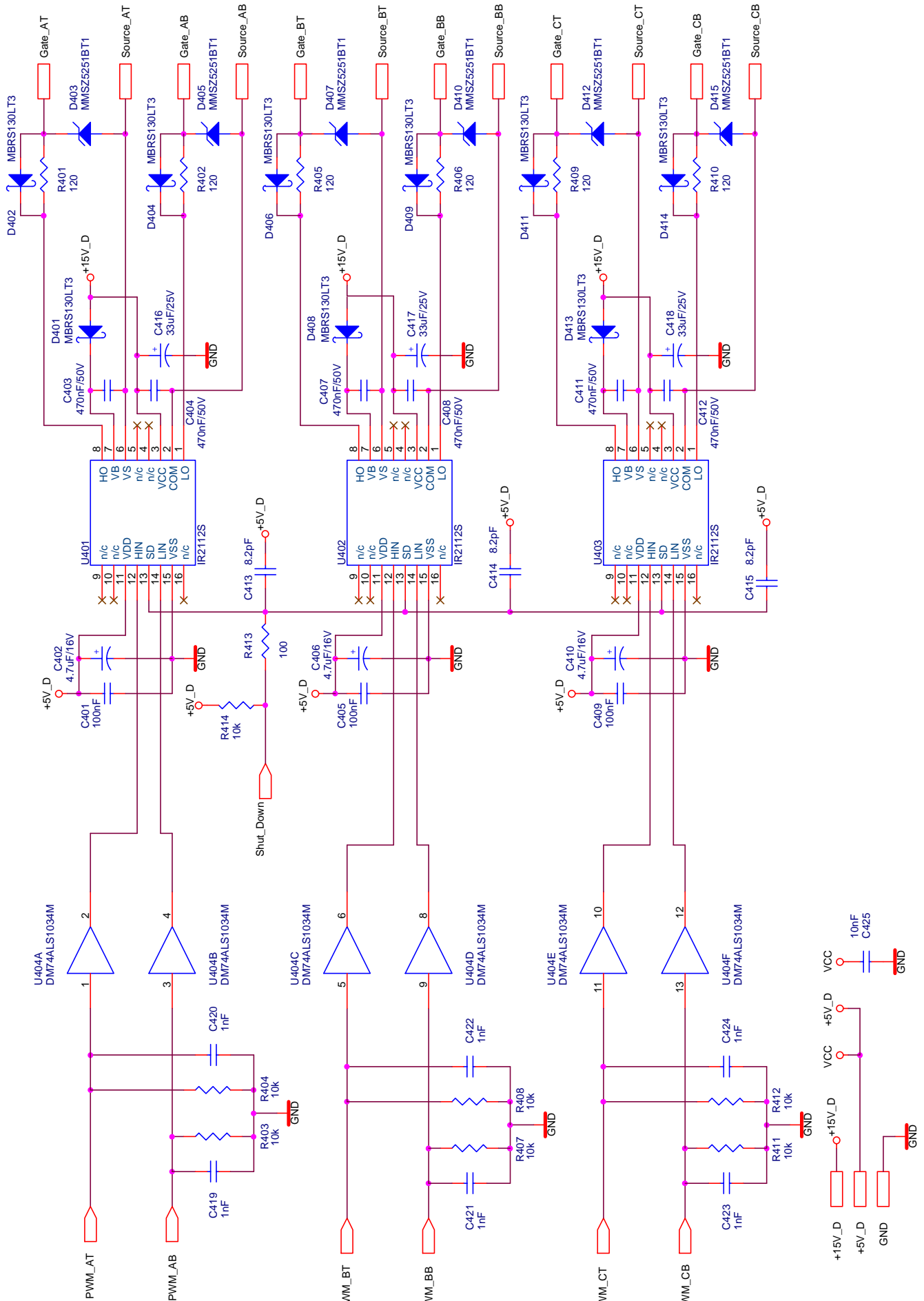

Figure 4-2. Gate Drive

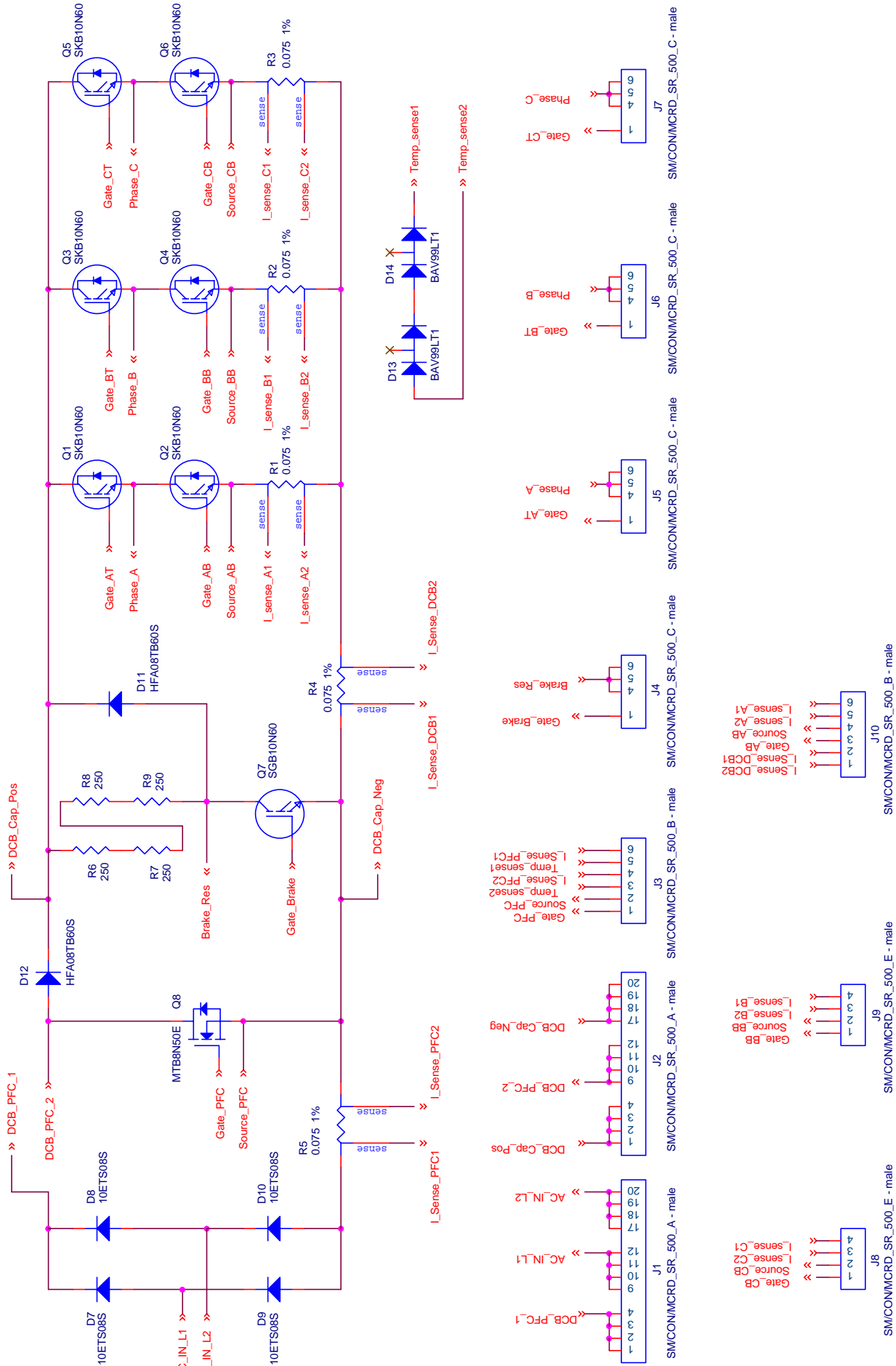

Figure 4-3. 3 Phase H-Bridge

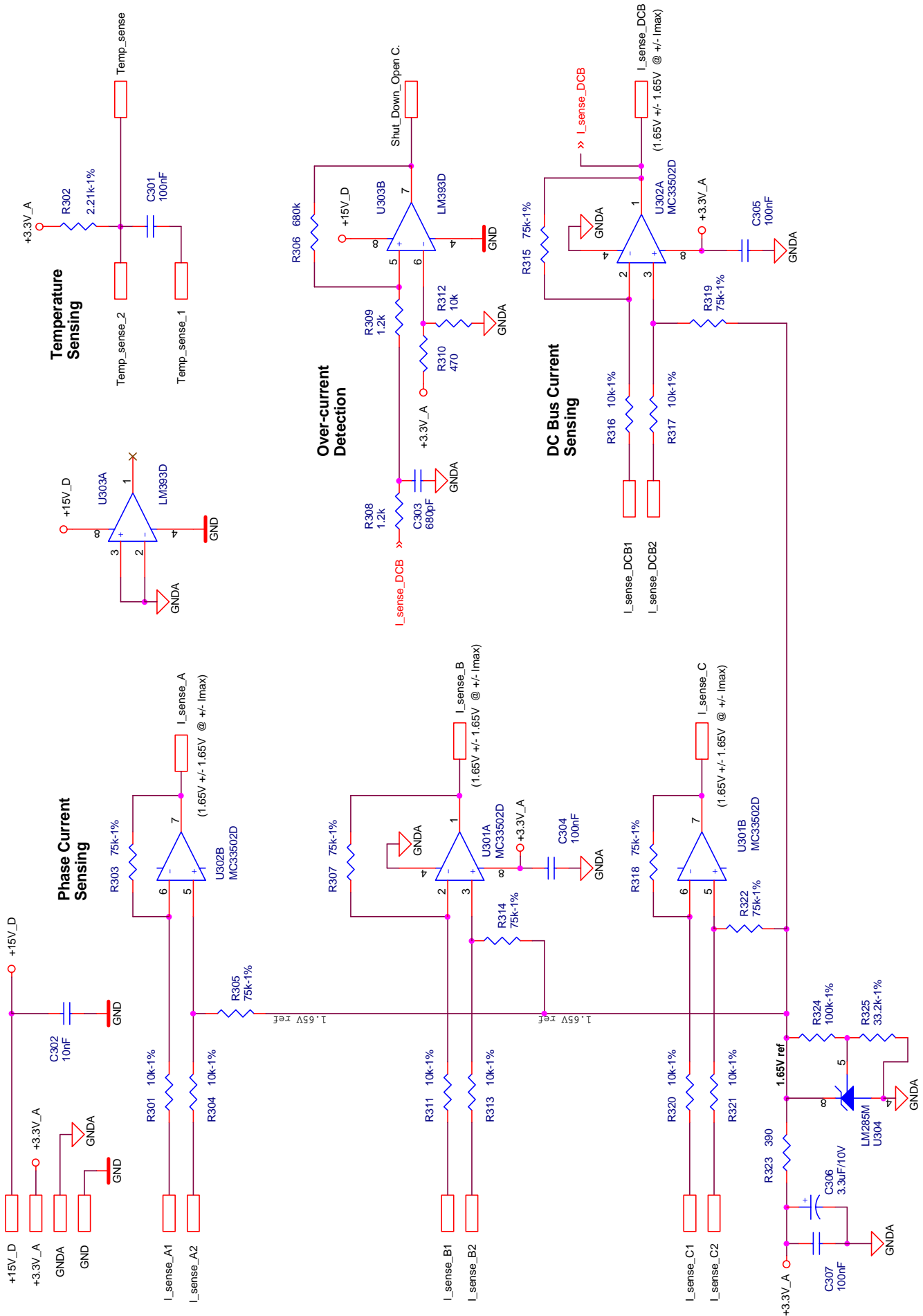

Figure 4-4. Current & Temperature Feedback

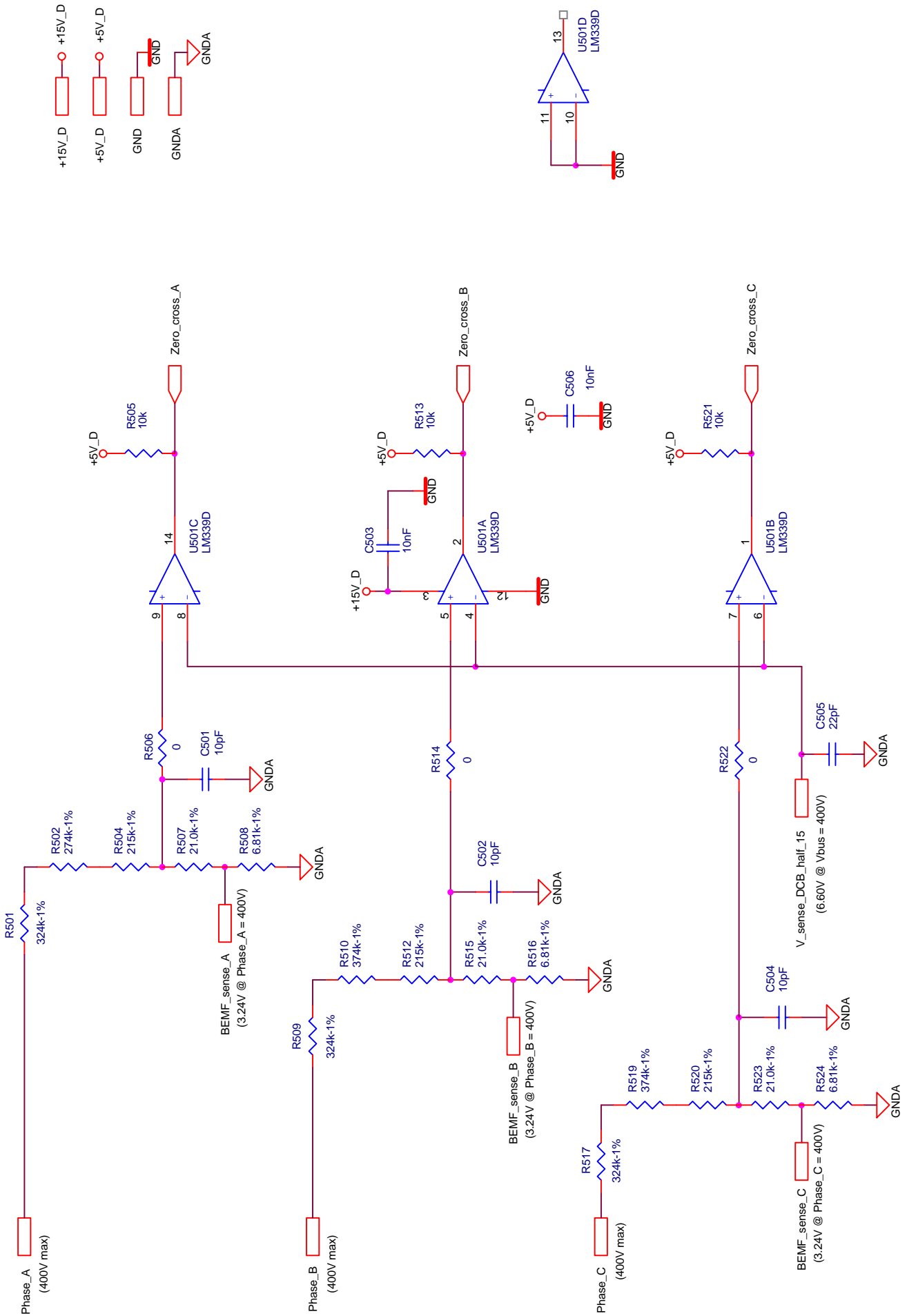
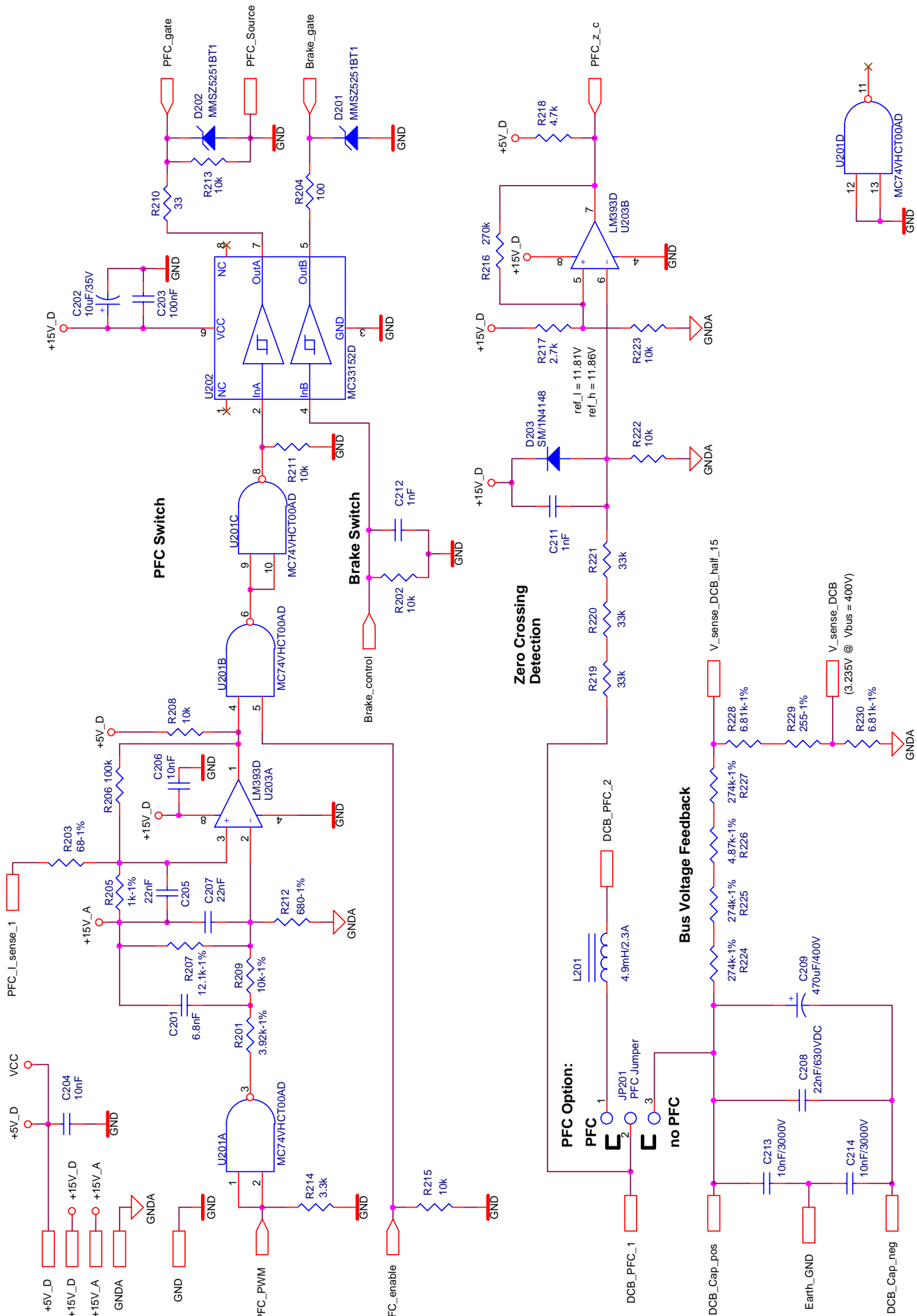

Figure 4-5. Back EMF Signals

For More Information On This Product,
Go to: www.freescale.com



For More Information On This Product, Go to: www.freescale.com

Figure 4-6. Power Factor Correction & Brake Gate Drives

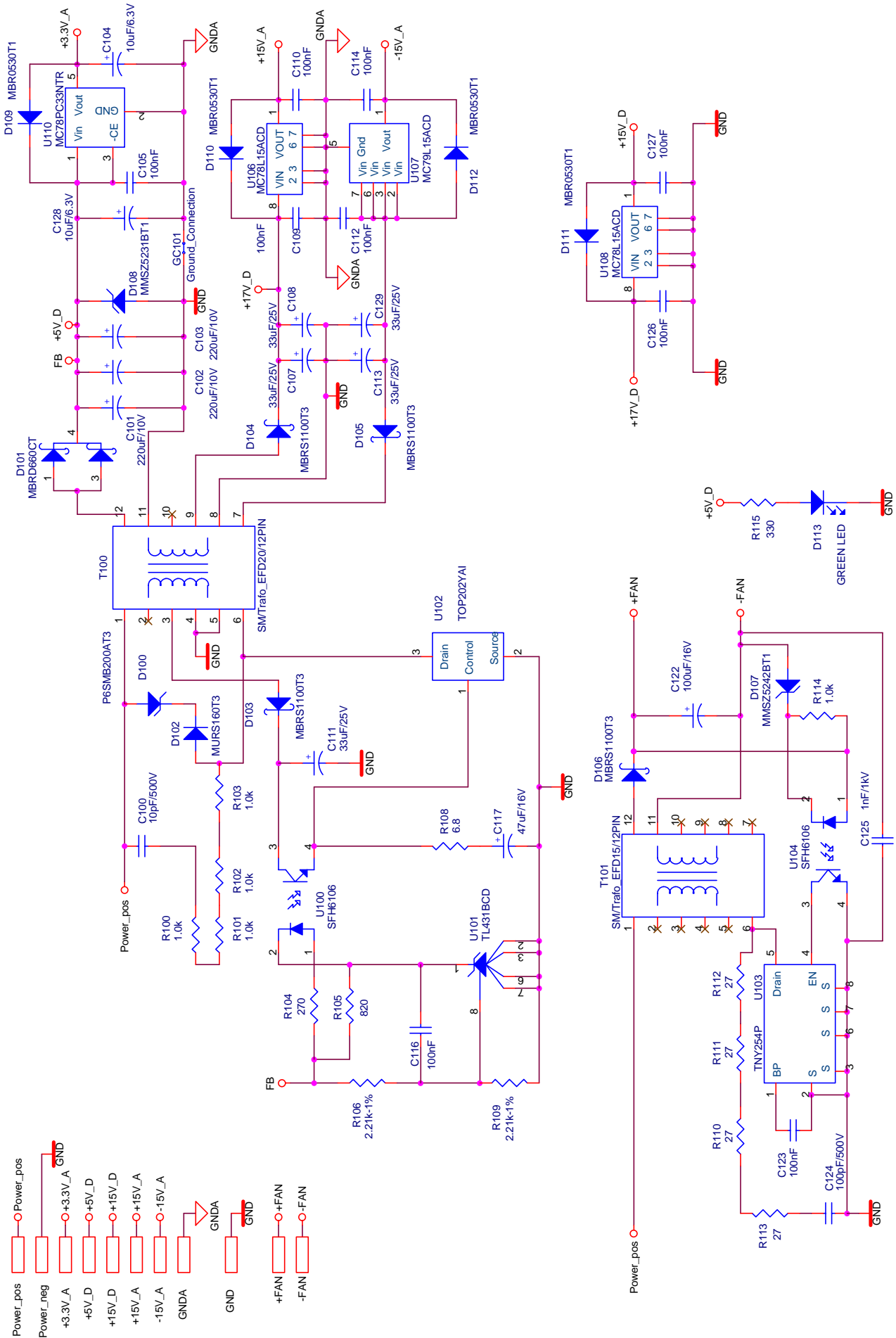

Figure 4-7. Power Supply

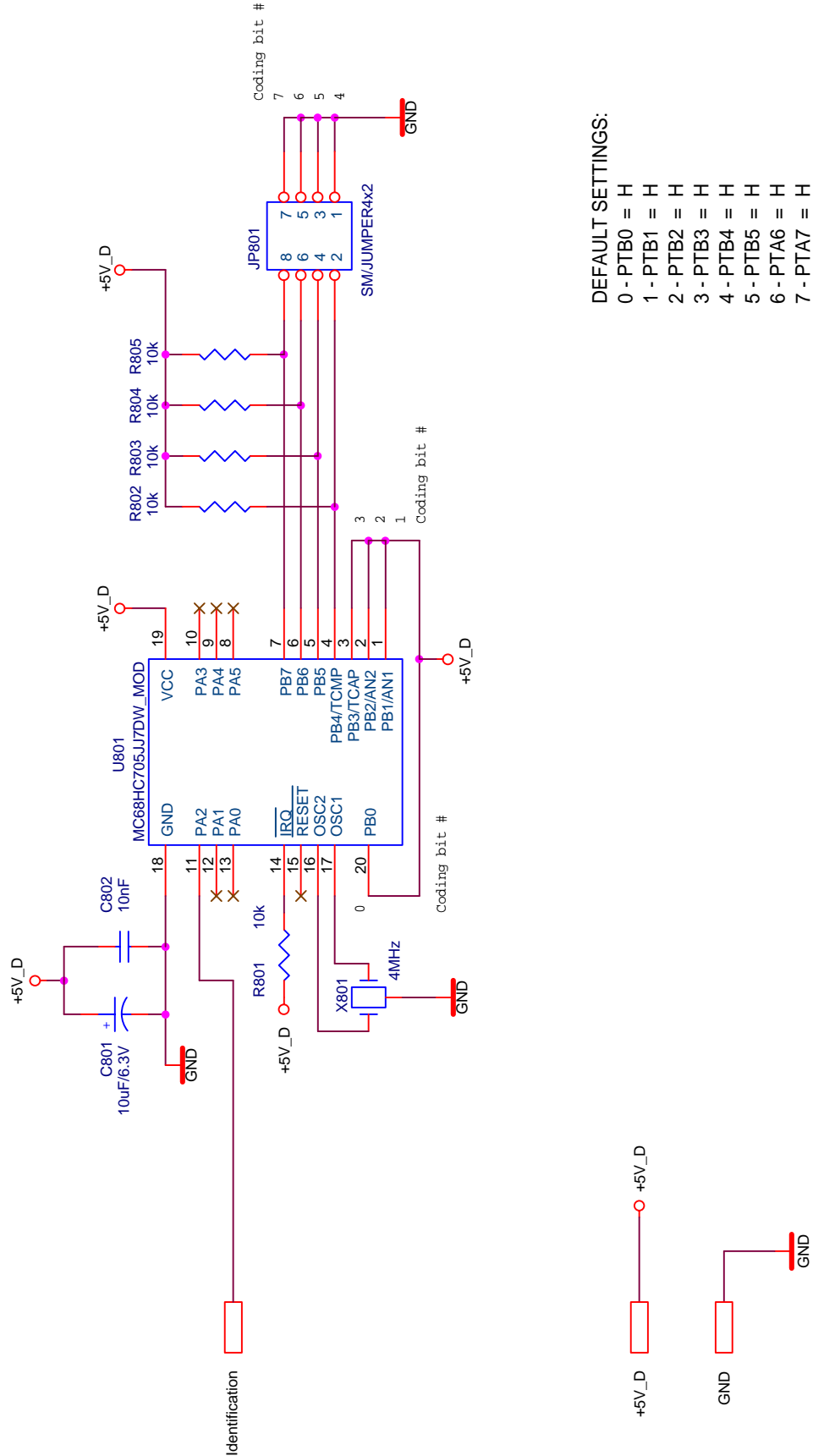

Figure 4-8. Identification Block

Schematics and Parts List
4.4 Parts Lists

The HV ac power stage's parts content is described in [Table 4-1](#) for the power substrate and in [Table 4-2](#) for the printed circuit board.

Table 4-1. Power Substrate Parts List

Designators	Qty	Description	Manufacturer	Part Number
D7, D8, D9, D10	4	10 A/800 V rectifier	International Rectifier	10ETS08S
D11, D12	2	8 A/600 V ultrafast rectifier	International Rectifier	HFA08TB60S
D13, D14	2	Dual diode — temp sensing	ON Semiconductor	BAV99LT1
J1, J2	2	SM/CON/MCRD_SR_500_A - male	Fisher Elektronik	SL 11 SMD 104 20Z
J3, J10	2	SM/CON/MCRD_SR_500_B - male	Fisher Elektronik	SL 10 SMD 104 6Z
J4, J5, J6, J7	4	SM/CON/MCRD_SR_500_C - male	Fisher Elektronik	SL 10 SMD 104 6Z
J8, J9	2	SM/CON/MCRD_SR_500_E - male	Fisher Elektronik	SL 10 SMD 104 4Z
Q1, Q2, Q3, Q4, Q5, Q6	6	10 A/600 V co-packaged IGBT	Infineon	SKB10N60
Q7	1	10 A/600 V IGBT	Infineon	SGB10N60
Q8	1	8 A/500 V MOSFET	ON Semiconductor	MTB8N50E
R1, R2, R3, R4, R5	5	0.075 Ω 1%	Isabellenhutte	PMA-A-R075-1
R6, R7, R8, R9	4	250 Ω	Caddock Electronics	MP725-250-5.0%
	1	Power substrate	CUBE	46615770

Table 4-2. Printed Circuit Board Parts List (Sheet 1 of 5)

Designators	Qty	Description	Manufacturer	Part Number
C1, C2, C105, C109, C110, C112, C114, C116, C123, C126, C127, C203, C301, C304, C305, C307, C401, C405, C409	19	100 nF/25 V	Vitramon	VJ0805U104MXXA_
C100	1	10 pF/500 V	Vishay Sprague	Typ:5GAQ10, Serie: 562C
C101, C102, C103	3	220 μ F/10 V	AVX	TPSE227K010R0100
C104,C128,C801	3	10 μ F/6.3 V	Sprague	293D106X_6R3B2_
C107, C108, C111, C113, C129, C416, C417, C418	8	33 μ F/25 V	AVX	TPSE336K025R0200
C117	1	47 μ F/16 V	Any available	
C122	1	100 μ F/16 V	AVX	TPSE107K016R0100
C204, C206, C302, C425, C503, C506, C802	7	10 nF/25 V	Vitramon	VJ0805U103MXXA_
C124	3	100 pF/500 V	Vishay Sprague	Typ:5GAT10, Serie: 562C
C125	1	1 nF/1 kV	muRata	DE0505E102Z1K
C201	1	6.8 nF	Vitramon	VJ0805A682JXA_
C202	1	10 μ F/35 V	Sprague	293D106X_035D2_
C205, C207	2	22 nF	Vitramon	VJ0805A223JXA_
C208	1	22 nF/630 Vdc	WIMA	MKP10
C209	1	470 μ F/400 V	Philips Components	15746471
C211, C212, C419, C420, C421, C422, C423, C424	8	1 nF	Vitramon	VJ0805A102JXA_
C213, C214	2	10 nF/ 3000 V	Thomson	5ST410MCMCA
C303	1	680 pF	Vitramon	VJ0805A681JXA_
C306	1	3.3 μ F/10 V	Sprague	293D335X_010A2_
C402, C406, C410	3	4.7 μ F/16 V	Sprague	293D475X_016B2_
C403, C404, C407, C408, C411, C412	6	470 nF/50 V	Vitramon	VJ1206U474MXAA_
C413, C414, C415	3	8.2 pF	Vitramon	VJ0805A8R2DXA_
C505	1	22 pF	Vitramon	VJ0805A220DXA_

Schematics and Parts List
Table 4-2. Printed Circuit Board Parts List (Sheet 2 of 5)

Designators	Qty	Description	Manufacturer	Part Number
D1	1	V14E250	EPCOS	SOIV-S-10K250
D100	1	Transient suppressor	ON Semiconductor	P6SMB200AT3
D101	1	6 A/60 V Schottky	ON Semiconductor	MBRD660CT
D102, D401, D408, D413	4	1 A/600 V ultrafast	ON Semiconductor	MURS160T3
D103, D104, D105, D106	4	1 A/100 V Schottky	ON Semiconductor	MBRS1100T3
D107	1	12 V/.5 W zener	ON Semiconductor	MMSZ5242BT1
D108	1	5.1 V/.5 W zener	ON Semiconductor	MMSZ5231BT1
D109, D110, D111, D112	4	0.5 A/30 V Schottky	ON Semiconductor	MBR0530T1
D113	1	Green LED	Kingbright	L-934GT
D201, D202, D403, D405, D407, D410, D412, D415	8	22 V/0.5 W zener	ON Semiconductor	MMSZ5251BT1
D203	1	1N4148	Fairchild	1N4148LL-34
D402, D404, D406, D409, D411, D414	6	1 A/30 V Schottky	ON Semiconductor	MBRS130LT3
F1	1	Fuse holder	MULTICOMP	MCHTE15M
JP201	1	Power jumper		
JP801	1	4X2 jumper pads		
J2, J1	2	20-pin connector	Fisher Elektronik	BL 2 20Z
J3, J10	2	6-pin connector	Fisher Elektronik	BL 1 6Z
J4, J5, J6, J7	4	6-pin connector	Fisher Elektronik	BL 1 6Z
J9, J8	2	4-pin connector	Fisher Elektronik	BL 1 4Z
J11, J12	2	Terminal block	Weidmuller	LP 7.62/2/90

Table 4-2. Printed Circuit Board Parts List (Sheet 3 of 5)

Designators	Qty	Description	Manufacturer	Part Number
J13	1	Terminal block	Weidmuller	LP 7.62/3/90
J14	1	40-pin connector	Fischer Elektronik	ASLG40G
L201	1	4.9 mH/2.3 A	Thompson Television Components	SMT4 ref G6982
R1	1	Inrush limiter	Rhopoint Components	SG190
R100, R101, R102, R103	4	1.0 k Ω	Dale	CRCW1206-102J
R104	1	270 Ω	Dale	CRCW0805-271J
R105	1	820 Ω	Dale	CRCW0805-821J
R106, R109	2	2.21 k Ω –1%	Any available	
R108	1	56 Ω	Any available	
R110, R111, R112, R113	4	27 Ω	Dale	CRCW1206-270J
R114	1	1.0 k Ω	Dale	CRCW0805-102J
R115	1	330 Ω	Dale	CRCW0805-331J
R201	1	3.92 k Ω –1%	Any available	
R202, 214	2	3.3 k Ω	Dale	CRCW0805-332J
R208, R211, R213, R215, R223, R312, R403, R404, R407, R408, R411, R412, R414, R505, R513, R521, R801, R802, R803, R804, R805	21	10 k Ω	Dale	CRCW0805-103J
R203	1	68.1 –1%	Any available	
R204, R413	2	100 Ω	Dale	CRCW0805-101J
R206	1	100 k Ω	Dale	CRCW0805-104J
R207	1	12.1 k Ω –1%	Any available	
R210	1	33 Ω	Dale	CRCW0805-330J
R212	1	681 Ω –1%	Any available	
R216	1	270 Ω	Dale	CRCW0805-274J
R217	1	2.7 k Ω	Dale	CRCW0805-272J

Schematics and Parts List
Table 4-2. Printed Circuit Board Parts List (Sheet 4 of 5)

Designators	Qty	Description	Manufacturer	Part Number
R218	1	4.7 k Ω	Dale	CRCW0805-472J
R219	1	33 k Ω	Dale	CRCW0805-333J
R220, R221	2	33 k Ω	Dale	CRCW0805-333J
R222	1	10 k Ω	Dale	CRCW0805-103J
R224, R225, R227, R502, R510, R519	6	274 k Ω –1%	Any available	
R226	1	4.87 k Ω –1%	Any available	
R228, R230, R508, R516, R524	5	6.81 k Ω –1%	Any available	
R229	1	255 Ω –1%	Any available	
R209, R301, R304, R311, R313, R316, R317, R320, R321	9	10 k Ω –1%	Dale	CRCW0805-103F
R302	1	2.21 k Ω –1%	Any available	
R205	1	1 k Ω –1%	Dale	CRCW0805-102F
R303, R305, R307, R314, R315, R318, R319, R322	8	75 k Ω –1%	Dale	CRCW0805-753F
R306	1	680 k Ω	Dale	CRCW0805-684J
R308, R309	2	1.2 k Ω	Dale	CRCW0805-122J
R310	1	220 Ω	Dale	CRCW0805-221J
R323	1	390 Ω	Dale	CRCW0805-391J
R324	1	100 k Ω –1%	Dale	CRCW0805-104F
R325	1	33.2 k Ω –1%	Any available	
R401, R402, R405, R406, R409, R410	6	120 Ω	Dale	CRCW0805-121J
R501, R509, R517	3	324 k Ω –1%	Any available	
R504, R512, R520	3	215 k Ω –1%	Any available	
R506, R514, R522	3	0	Any available	
R507, R515, R523	3	21.0 k Ω –1%	Any available	
T100	1	SMPS transformer	Tronic Praha s.r.o	TRONIC 99 060 09

Table 4-2. Printed Circuit Board Parts List (Sheet 5 of 5)

Designators	Qty	Description	Manufacturer	Part Number
T101	1	SMPS transformer	Tronic Praha s.r.o	TRONIC 00 003 73
U100, U104	2	Optocoupler	Infineon	SFH6106-2
U101	1	Voltage reference	ON Semiconductor	TL431BCD
U102	1	SMPS controller	Power Integration	TOP202YAI
U103	1	SMPS controller	Power Integration	TNY254P
U108, U106	2	15 V/.1 A regulator	ON Semiconductor	MC78L15ACD
U107	1	- 15 V/0.1 A regulator	ON Semiconductor	MC79L15ACD
U110	1	3.3 V/.15 A regulator	ON Semiconductor	MC78PC33NTR
U201	1	Quad 2-input NAND gate	ON Semiconductor	MC74VHCT00AD
U202	1	Dual gate driver	ON Semiconductor	MC33152D
U203, U303	2	Dual comparator	ON Semiconductor	LM393D
U301, U302	2	Dual op amp	ON Semiconductor	MC33502D
U304	1	Voltage reference	National Semiconductor	LM285M
U401, U402, U403	3	Dual gate driver	International Rectifier	IR2112S
U404	1	Hex non-inverting driver	Fairchild	DM74ALS1034M
U501	1	Quad comparator	ON Semiconductor	LM339D
U801	1	Microcontroller	Motorola	MC68HC708JJ7CDW
X801	1	4-MHz resonator	muRata	CSTCC4.00MG



Section 5. Design Considerations

5.1 Contents

5.2	Overview	47
5.3	3-Phase H-Bridge	48
5.4	Bus Voltage and Current Feedback	50
5.5	Cycle-by-Cycle Current Limiting	52
5.6	Temperature Sensing	54
5.7	Back EMF Signals	55
5.8	Phase Current Sensing	56
5.9	Brake	57
5.10	Power Factor Correction	58

5.2 Overview

From a systems point of view, the HV ac power stage fits into an architecture that is designed for software development. In addition to the hardware that is needed to run a motor, a variety of feedback signals that facilitate control algorithm development and a PFC circuit are provided.

Circuit descriptions for the HV ac power stage appear in [5.3 3-Phase H-Bridge](#) through [5.10 Power Factor Correction](#). One phase leg of the 3-phase H-bridge is looked at in [5.3 3-Phase H-Bridge](#). Bus voltage and bus current feedback are discussed in [5.4 Bus Voltage and Current Feedback](#). Cycle-by-cycle current limiting is highlighted in [5.5 Cycle-by-Cycle Current Limiting](#). Temperature sensing is discussed in [5.6 Temperature Sensing](#). Back-EMF signals appear in [5.7 Back EMF Signals](#). Phase current sensing is discussed in [5.8 Phase Current Sensing](#). The brake is highlighted in [5.9 Brake](#), and finally power factor correction is discussed in [5.10 Power Factor Correction](#).

5.3 3-Phase H-Bridge

The output stage is configured as a 3-phase H-bridge with IGBT output transistors. It is simplified considerably by high-voltage integrated gate drivers that have a cycle-by-cycle current limit feature. A schematic that shows one phase is illustrated in [Figure 5-1](#).

At the input, pulldown resistors R403 and R404 set a logic low in the absence of a signal. Open input pulldown is important, since it is desirable to keep the power transistors off in case of either a broken connection or absence of power on the control board. The drive signal is buffered by U404A and U404B. This part has a minimum logic 1 input voltage of 2.0 volts and a maximum logic 0 input voltage of 0.8 volts, which allows for inputs from either 3.3- or 5-volt logic. Gate drive is supplied by an international rectifier, IR2112. Undervoltage lockout and cycle-by-cycle current limiting are also provided by the IR2112. Undervoltage lockout is set nominally at 8.4 volts. Current limiting is discussed further in [5.5 Cycle-by-Cycle Current Limiting](#).

One of the more important design decisions in a motor drive is selection of gate drive impedance for the output transistors. In [Figure 5-1](#), resistor R402, diode D404, and the IR2112's nominal 500-mA current sinking capability determine gate drive impedance for the lower half-bridge transistor. A similar network is used on the upper half-bridge. These networks set turn-on gate drive impedance at approximately 120 ohms and turn-off gate drive to approximately 500 mA. These values produce transition times of approximately 200 ns.

Transition times of this length represent a carefully weighed compromise between power dissipation and noise generation. Generally, transition times longer than 250 ns tend to get power hungry at non-audible PWM rates; and transition times under 50 ns create di/dt 's so large that proper operation is difficult to achieve. The HV ac power stage is designed with switching times at the higher end of this range to minimize noise.

Anti-parallel diode softness is also a first order design consideration. If the anti-parallel diodes in an off-line motor drive are allowed to snap, the resulting di/dt 's can cause noise management problems that are difficult to solve. In general, it is desirable to have peak to zero di/dt approximately equal the applied di/dt that is used to turn the anti-parallel diodes off. The SKB10N60 IGBT's that are used in this design are targeted at this kind of reverse recovery characteristic.

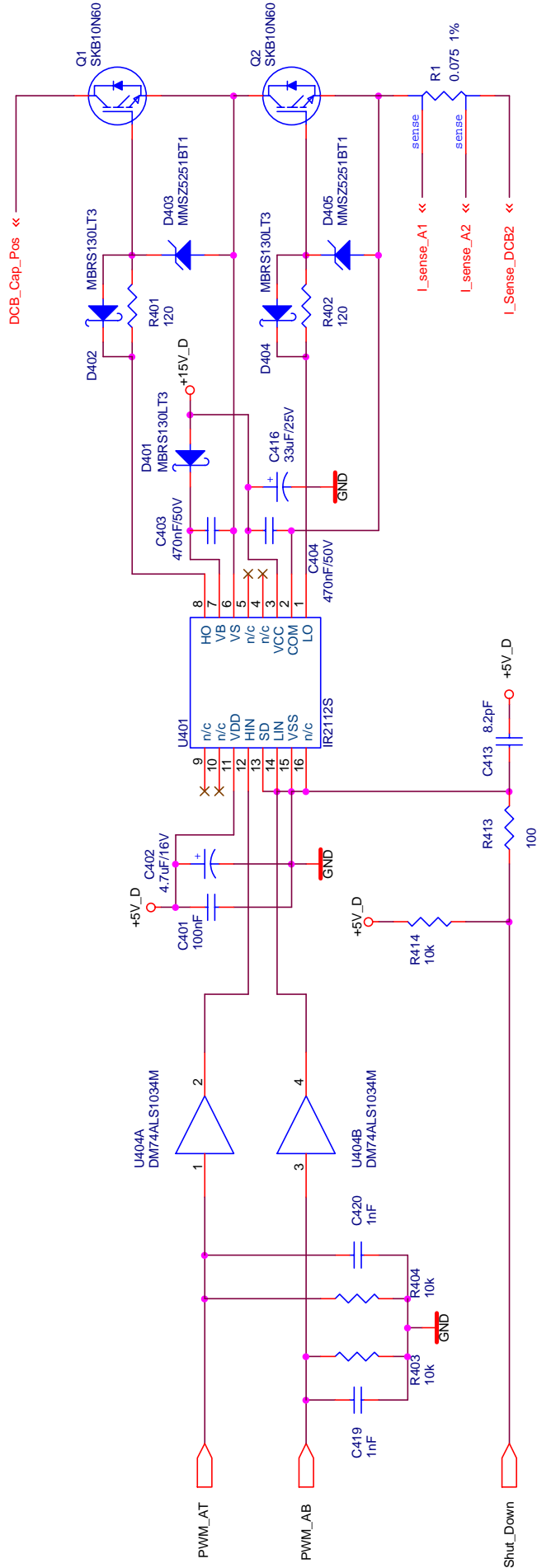

Figure 5-1. Phase A Output

5.4 Bus Voltage and Current Feedback

Feedback signals proportional to bus voltage and bus current are provided by the circuitry shown in [Figure 5-2](#). Bus voltage is scaled down by a voltage divider consisting of R224 –R230.

The values are chosen such that a 400-volt maximum bus voltage corresponds to 3.24 volts at output V_sense_DCB. An additional output, V_sense_DCB_half_15, provides a reference used in zero crossing detection.

Bus current is sampled by resistor R4 in [Figure 4-3](#), and amplified by the circuit in [Figure 5-2](#). This circuit provides a voltage output suitable for sampling with A/D (analog-to-digital) inputs. An MC33502 is used for the differential amplifier. With R315 = R319 and R316 = R317, the gain is given by:

$$A = R315/R316$$

The output voltage is shifted up by 1.65 V to accommodate both positive and negative current swings. A ± 300 -mV voltage drop across the sense resistor corresponds to a measured current range of ± 2.93 amps. In addition to providing an A/D input, this signal also is used for cycle-by-cycle current limiting. A discussion of cycle-by-cycle current limiting follows in [5.3 3-Phase H-Bridge](#).

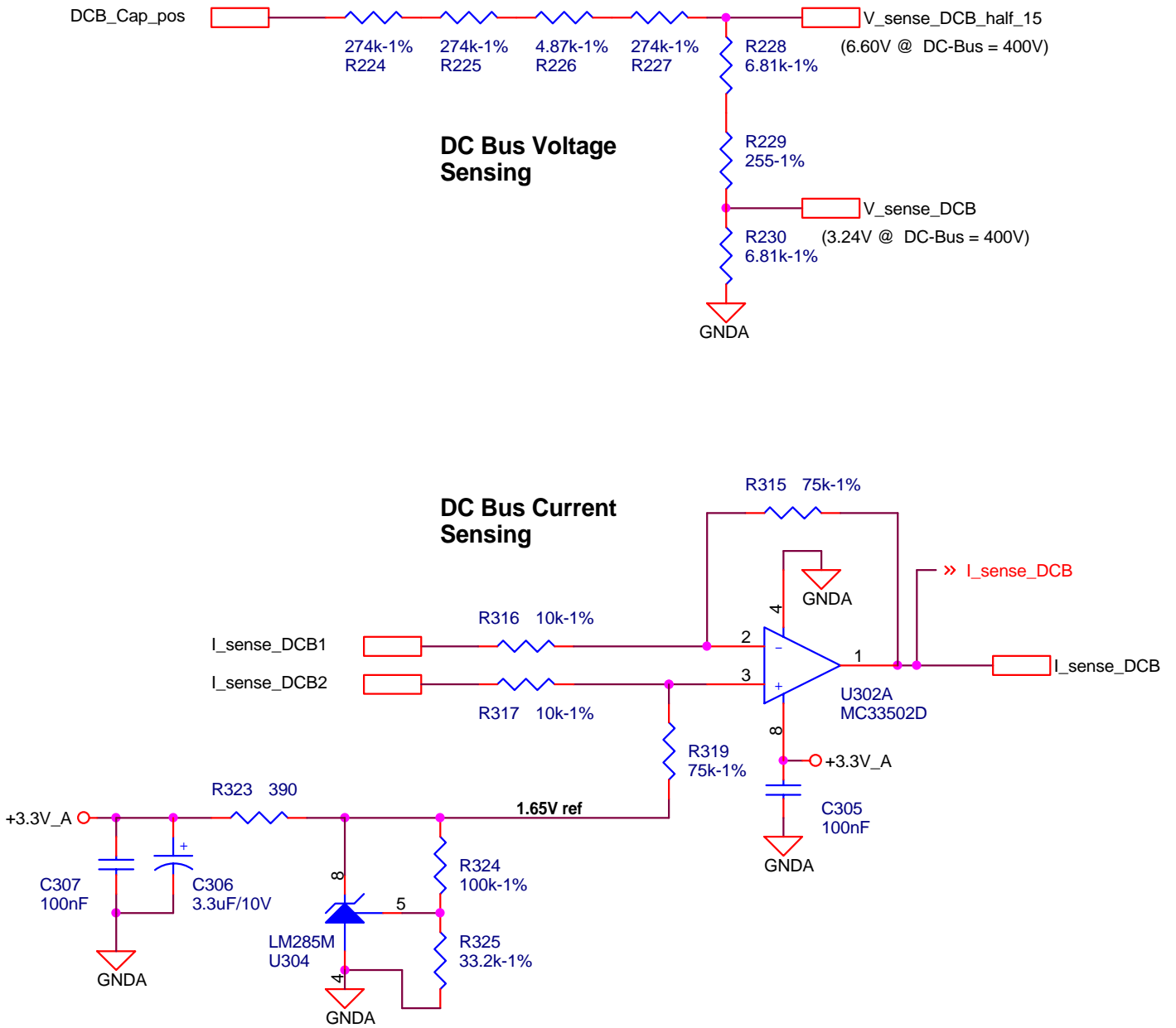

Figure 5-2. Bus Feedback

5.5 Cycle-by-Cycle Current Limiting

Cycle-by-cycle current limiting is provided by the circuitry illustrated in **Figure 5-3**. Bus current feedback signal, I_sense_DCB, is filtered with R308 and C303 to remove spikes, and then compared to a 3.15-volt reference with U303B. The open collector output of U303B is pulled up by R414. Additional filtering is provided by C413, C414, and C415. The resulting signal is fed into the IR2112 gate driver's shutdown input on all three phases. Therefore, when bus current exceeds 2.69 amps, all six output transistors are switched off.

The IR2112's shutdown input is buffered by RS latches for both top and bottom gate drives. Once a shutdown signal is received, the latches hold the gate drive off for each output transistor, until that transistor's gate drive signal is switched low, and then is turned on again. Hence, current limiting occurs on a cycle-by-cycle basis.

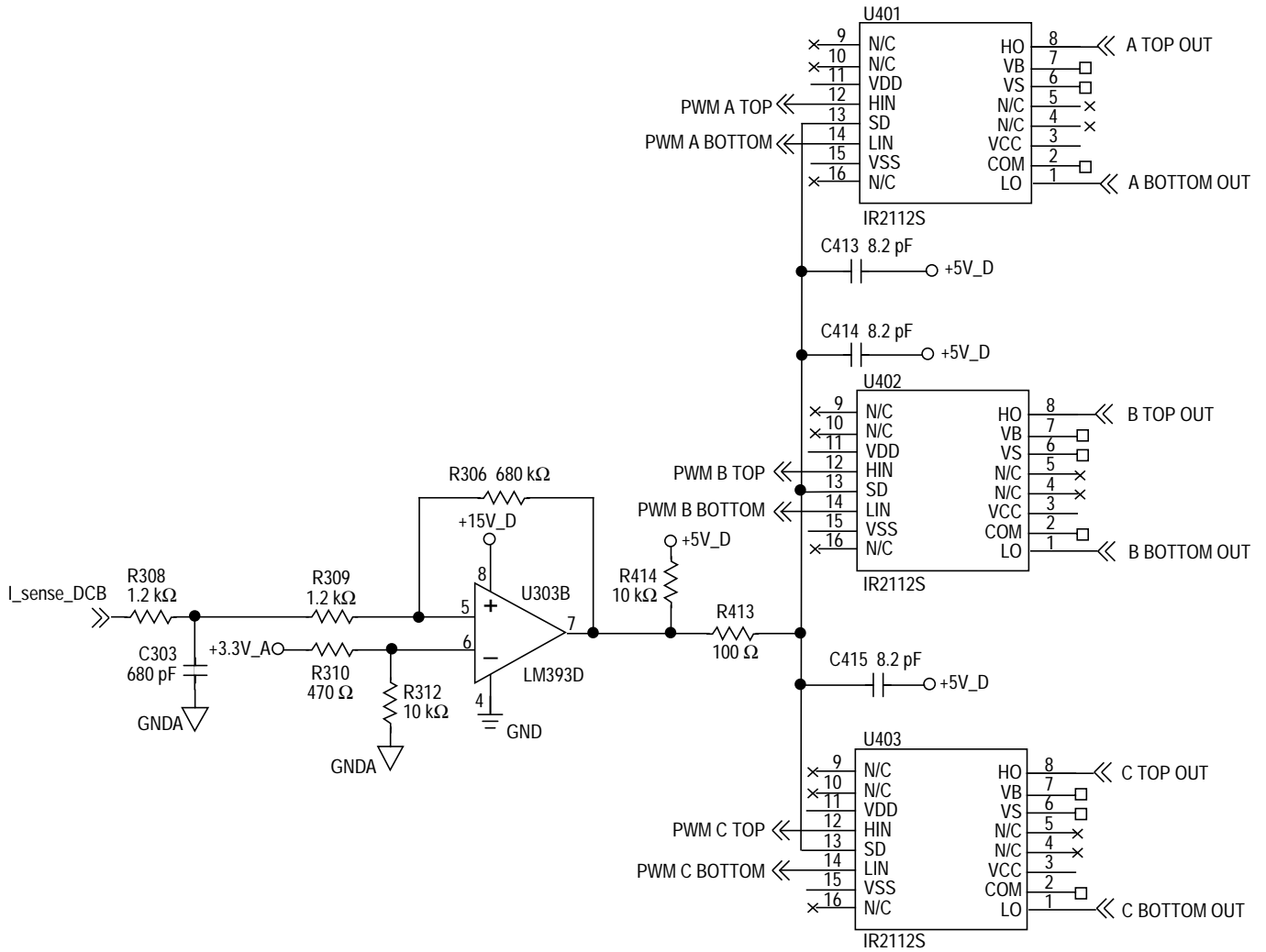

Figure 5-3. Cycle-by-Cycle Current Limiting

5.6 Temperature Sensing

Cycle-by-cycle current limiting keeps average bus current within safe limits. Current limiting by itself, however, does not necessarily ensure that a power stage is operating within safe thermal limits. For thermal protection, the circuit in **Figure 5-4** is used. It consists of four diodes connected in series, a bias resistor, and a noise suppression capacitor. The four diodes have a combined temperature coefficient of $8.8 \text{ mV}/^\circ\text{C}$. The resulting signal, Temp_sense, is fed back to an A/D input where software can be used to set safe operating limits.

Due to unit-to-unit variations in diode forward voltage, it is highly desirable to calibrate this signal. To do so, a value for Temp_sense is read at a known temperature and then stored in nonvolatile memory. The measured value, rather than the nominal value, is then used as a reference point for further readings.

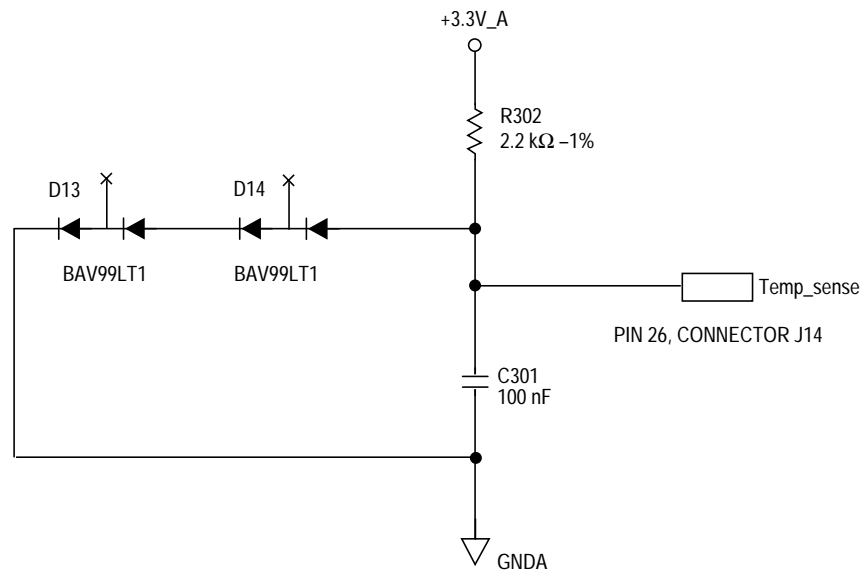

Figure 5-4. Temperature Sensing

5.7 Back EMF Signals

Back EMF and zero crossing signals are included to support sensorless algorithms for brushless dc motors and dead time distortion correction for ac induction motors. Referring to **Figure 5-5**, which shows circuitry for phase A, the raw phase voltage is scaled down by a voltage divider consisting of R501, R502, R504, R507, and R508. One output from this divider produces back EMF sense voltage BEMF_sense_A. Resistor values are chosen such that a 400-volt maximum phase voltage corresponds to a 3.24-volt maximum A/D input. A zero crossing signal is obtained by comparing motor phase voltage with one-half the motor bus voltage. Comparator U501C performs this function, producing zero crossing signal Zero_cross_A.

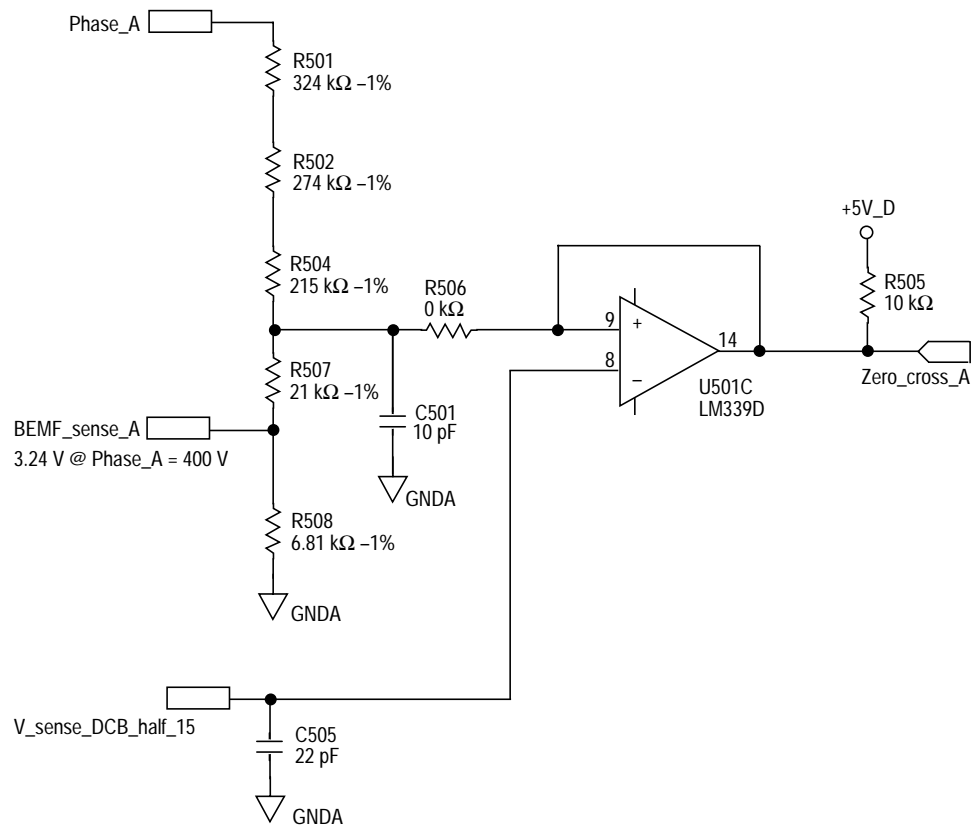

Figure 5-5. Phase A Back EMF

5.8 Phase Current Sensing

Lower half-bridge sampling resistors provide phase current information for all three phases. Since these resistors sample current in the lower phase legs, they do not directly measure phase current. However, given phase voltages for all three phases, phase current can be constructed mathematically from the lower phase leg values. This information can be used in vector control algorithms for ac induction motors. The measurement circuitry for one phase is shown in [Figure 5-6](#).

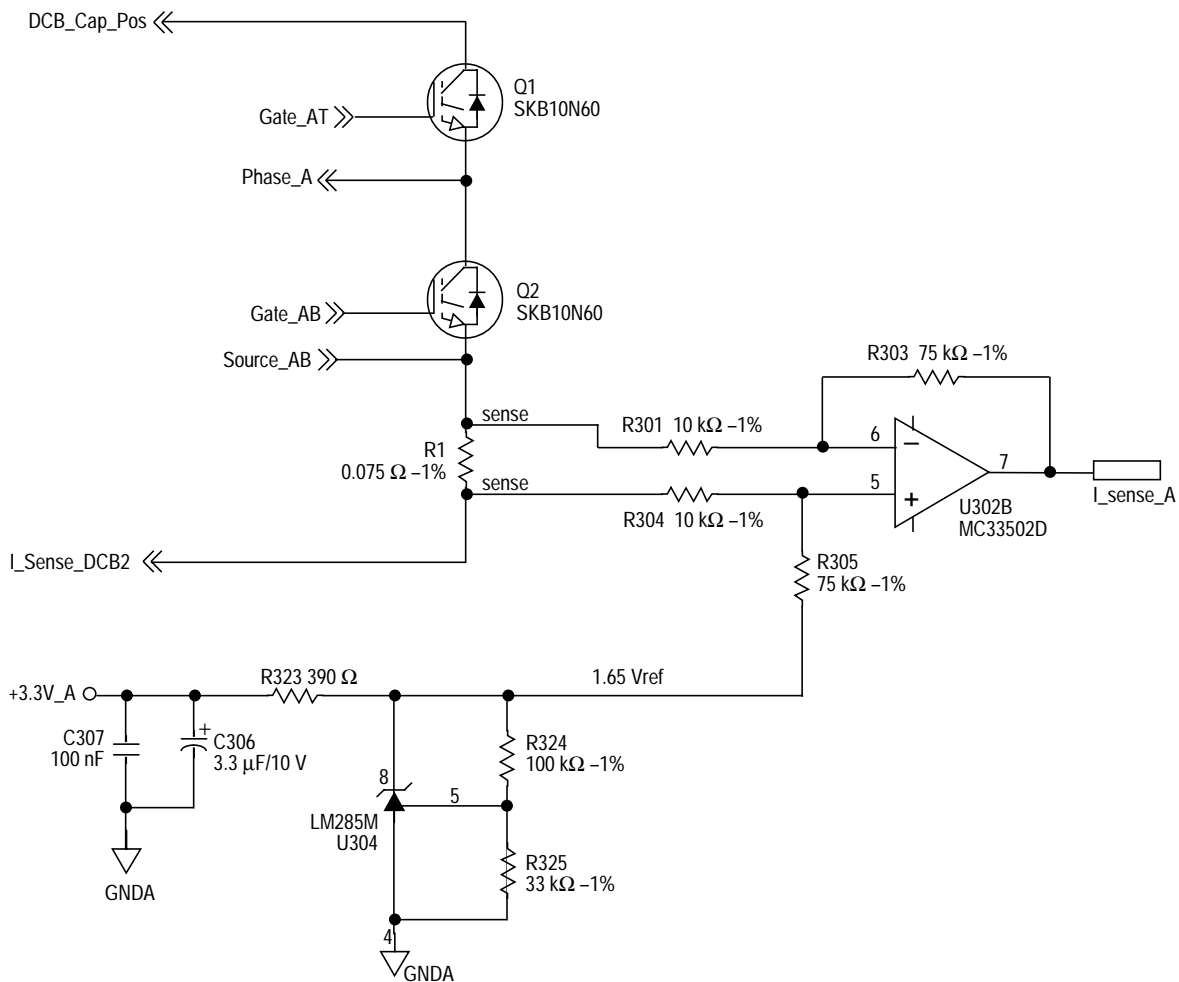

Figure 5-6. Phase A Current Sensing

Referencing the sampling resistors to the negative motor rail makes the measurement circuitry straightforward and inexpensive. Current is sampled by resistor R1, and amplified by differential amplifier U302B. This circuit provides a voltage output suitable for sampling with A/D inputs. An MC33502 is again used for the differential amplifier. With $R301 = R302$ and $R303 = R305$, the gain is given by:

$$A = R303/R301$$

The output voltage is shifted up by 1.65 V to accommodate both positive and negative current swings. A ± 300 -mV voltage drop across the shunt resistor corresponds to a measured current range of ± 2.69 amps.

5.9 Brake

A brake circuit is included to dissipate re-generative motor energy during periods of active deceleration or rapid reversal. Under these conditions, motor back EMF adds to the dc bus voltage. Without a means to dissipate excess energy, an overvoltage condition could easily occur.

The circuit shown in [Figure 5-7](#) connects R6–R9 across the dc bus to dissipate energy. Q7 is turned on by software when the bus voltage sensing circuit in [Figure 5-2](#) indicates that bus voltage could exceed safe levels. On-board power resistors R6–R9 will safely dissipate up to 50 watts continuously or up to 100 watts for 15 seconds. Additional power dissipation capability can be added externally via brake connector J12.

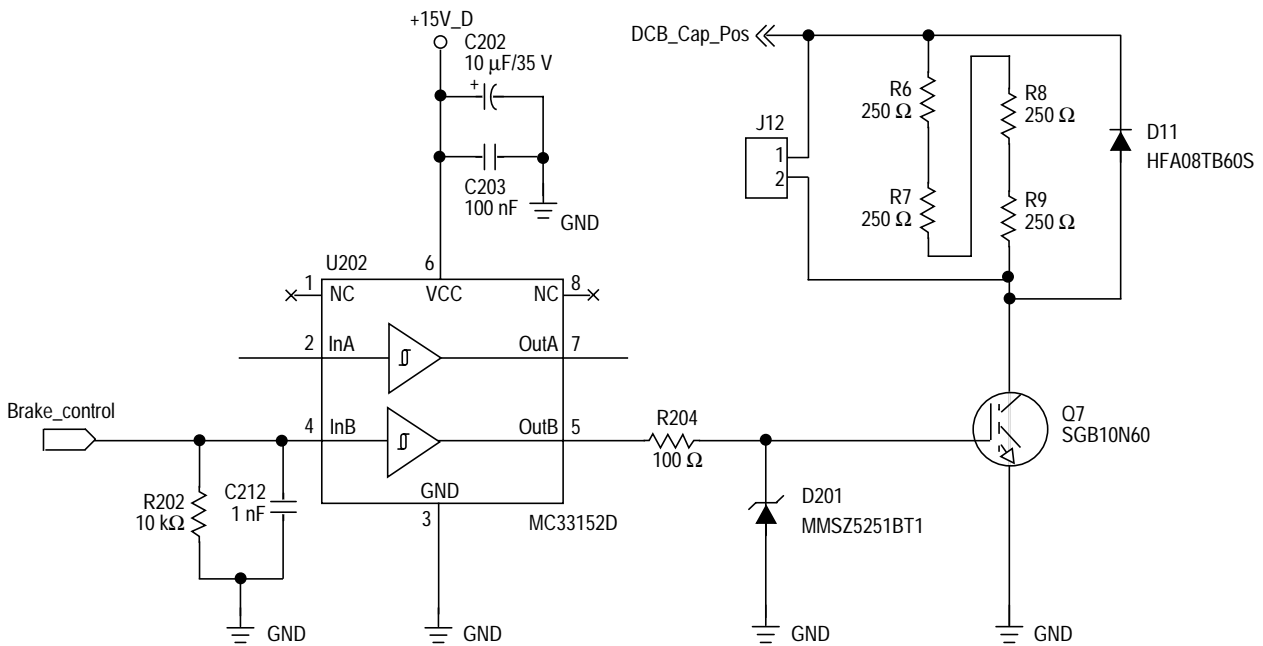

Figure 5-7. Brake

5.10 Power Factor Correction

A power factor correction (PFC) circuit is included to facilitate development of software that includes PFC control features. The objective of the PFC hardware and software is to draw sinusoidal current from the ac line, in an attempt to approach as closely as possible a unity power factor. Without PFC, current is drawn from the ac line at the peak of the sine wave, when the ac line voltage exceeds the dc bus voltage. PFC circuitry is illustrated in [Figure 5-8](#).

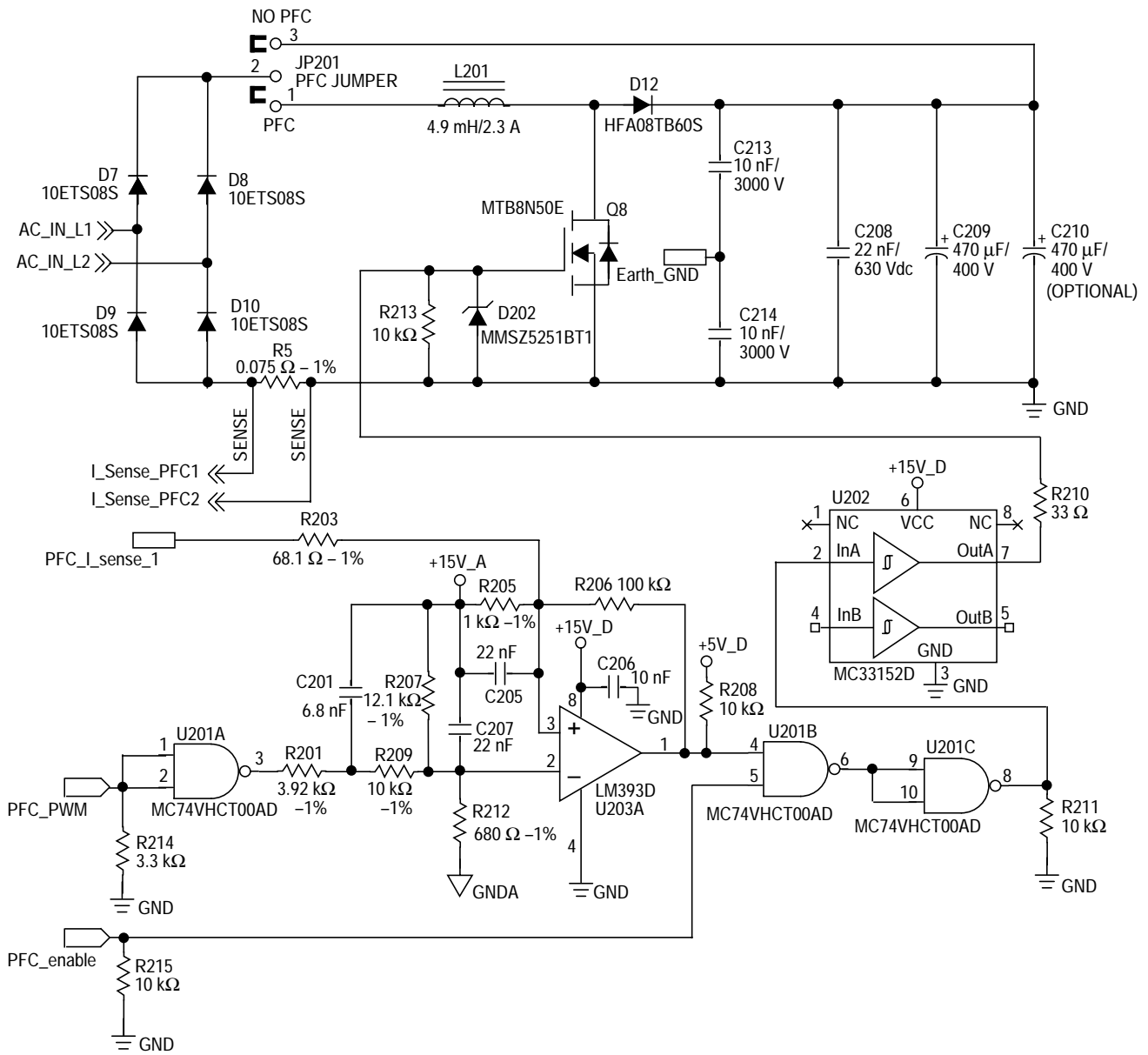

Figure 5-8. PFC Circuitry

Looking toward the top of [Figure 5-8](#), Q8, L201, D12, and the bus capacitors form a boost power supply. This configuration allows current to be drawn from the ac line, when line voltage is lower than the dc bus voltage. Pulse-width modulation is controlled by software and augmented by the analog circuitry in the lower half of [Figure 5-8](#). Voltage feedback is provided by the bus voltage sensing circuit in [Figure 5-2](#). A zero crossing feedback signal, PFC_z_c, is also used and is produced by the circuit in [Figure 5-9](#).

Design Considerations

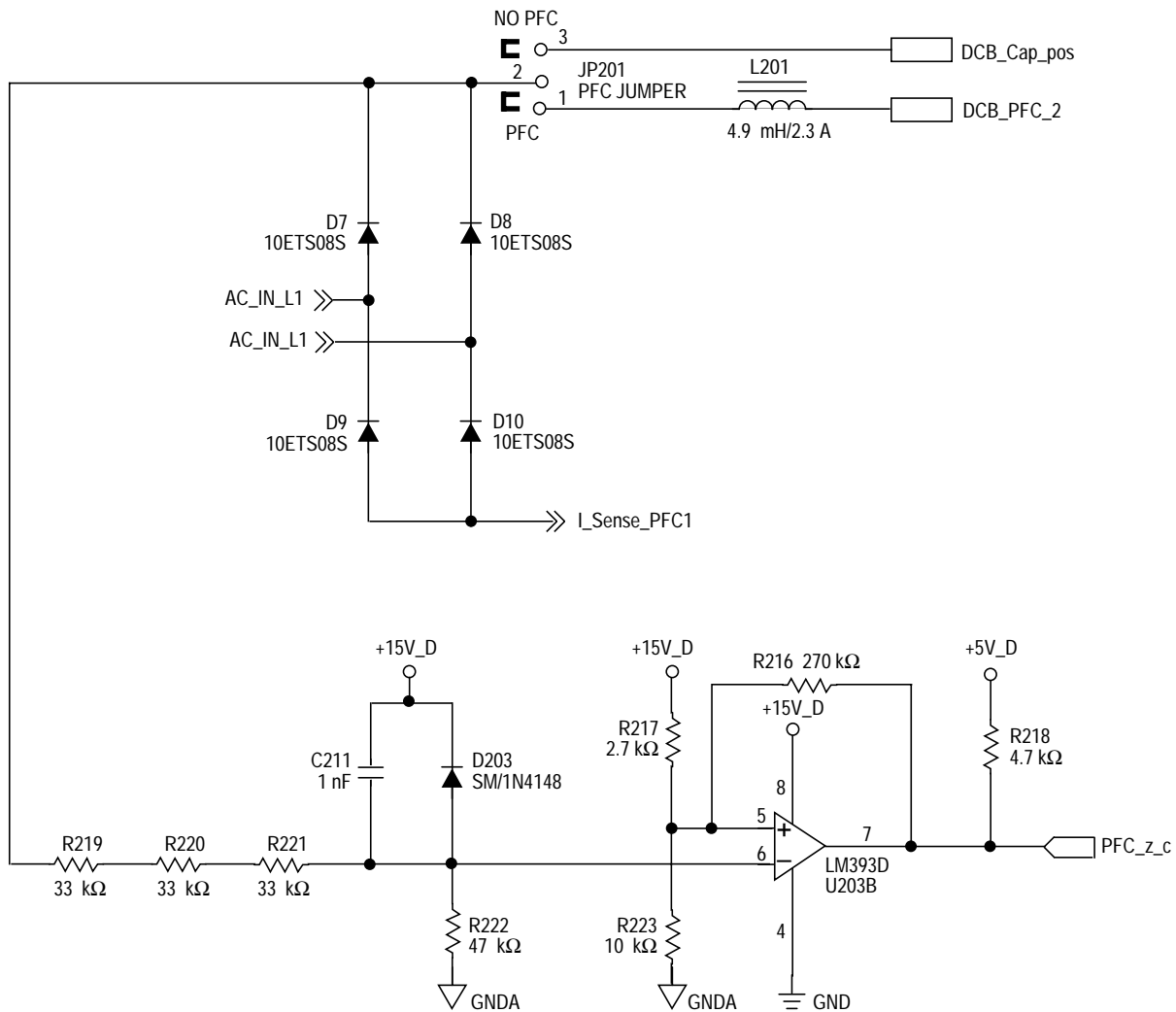

Figure 5-9. PFC Zero Crossing Feedback

In this circuit, R219, R220, and R221 provide a relatively high impedance connection to the rectified line voltage, and form a .32:1 voltage divider with R222. D203 clamps the divided down voltage to approximately 15.7 volts. Comparator U203B then compares this signal to a 11.8-volt reference. Approximately fifty millivolts of hysteresis is added by R216. The result is a logic high at output PFC_z_c when the comparator's input voltage falls below 11.79 volts. This output remains high until 10.84 volts is reached on the next cycle.



Freescale Semiconductor, Inc.

Freescale Semiconductor, Inc.

**For More Information On This Product,
Go to: www.freescale.com**

Motorola reserves the right to make changes without further notice to any products herein. Motorola makes no warranty, representation or guarantee regarding the suitability of its products for any particular purpose, nor does Motorola assume any liability arising out of the application or use of any product or circuit, and specifically disclaims any and all liability, including without limitation consequential or incidental damages. "Typical" parameters which may be provided in Motorola data sheets and/or specifications can and do vary in different applications and actual performance may vary over time. All operating parameters, including "Typicals" must be validated for each customer application by customer's technical experts. Motorola does not convey any license under its patent rights nor the rights of others. Motorola products are not designed, intended, or authorized for use as components in systems intended for surgical implant into the body, or other applications intended to support or sustain life, or for any other application in which the failure of the Motorola product could create a situation where personal injury or death may occur. Should Buyer purchase or use Motorola products for any such unintended or unauthorized application, Buyer shall indemnify and hold Motorola and its officers, employees, subsidiaries, affiliates, and distributors harmless against all claims, costs, damages, and expenses, and reasonable attorney fees arising out of, directly or indirectly, any claim of personal injury or death associated with such unintended or unauthorized use, even if such claim alleges that Motorola was negligent regarding the design or manufacture of the part. Motorola and  are registered trademarks of Motorola, Inc. Motorola, Inc. is an Equal Opportunity/Affirmative Action Employer.

How to reach us:

USA/EUROPE/Locations Not Listed: Motorola Literature Distribution, P.O. Box 5405, Denver, Colorado 80217. 1-303-675-2140 or 1-800-441-2447. Customer Focus Center, 1-800-521-6274

JAPAN: Motorola Japan Ltd.; SPS, Technical Information Center, 3-20-1, Minami-Azabu, Minato-ku, Tokyo 106-8573 Japan. 81-3-3440-8573

ASIA/PACIFIC: Motorola Semiconductors H.K. Ltd.; Silicon Harbour Centre, 2 Dai King Street, Tai Po Industrial Estate, Tai Po, N.T., Hong Kong. 852-26668334

HOME PAGE: <http://motorola.com/semiconductors/>



MOTOROLA

© Motorola, Inc., 2000

MEMC3PBLDCPSUM/D

**For More Information On This Product,
Go to: www.freescale.com**