

June, 2010

MPC563xM/MPC564xA Low-End Engine Control Hardware Design

FTF-AUT-F0679

Randy Dees
MSG Automotive Applications





Agenda

- ▶ **Session objectives**
- ▶ System block diagram and overview
- ▶ MPC563xM powertrain advantages and overview
- ▶ Secondary safety MCU
- ▶ SmartMOS devices
- ▶ Pressure sensor
- ▶ Software drivers and libraries
- ▶ Mechanics
- ▶ Summary



- ▶ This seminar presents the minimum hardware requirements (power supply and external components) for designing an engine controller using MPC5634M Power Architecture microcontrollers, including interfacing to Freescale Analog SmartMOS devices. This seminar covers the MPC5634M Reference Design module for a 4-cylinder MPC5634M engine control module (ECM), including an overview of the software (AutoSAR-based, eTPU driver overview) that will be available from Freescale to support this design.

Note: Not all slides in this presentation can be presented during a 1 hour training session. A reduced set will be covered that covers the objective listed above. The additional slides provide additional information that may be useful in designing a system.

MPC563xM-based Four-cylinder Engine Reference Design

- ▶ Basic but fully functional Engine Control Unit
- ▶ Capable of running a four-cylinder gasoline engine
 - Meeting stringent emissions standards
- ▶ Robust enclosure
 - Permits customer evaluation on dynamometer and in vehicle
- ▶ Low-level software provided
 - Simple maps for fuel and spark
 - Closed loop idle control
 - Enough to run an engine but not to meet emissions standards
 - Not production quality
- ▶ Calibration using CCP/XCP
- ▶ Basic on board diagnostics using Freescale analog devices
- ▶ Documentation package





Agenda

- ▶ Session objectives
- ▶ **System block diagram and overview**
- ▶ MPC563xM powertrain advantages and overview
- ▶ Secondary safety MCU
- ▶ SmartMOS devices
- ▶ Pressure sensor
- ▶ Software drivers and libraries
- ▶ Mechanics
- ▶ Summary



MPC5634M ECU Block Diagram

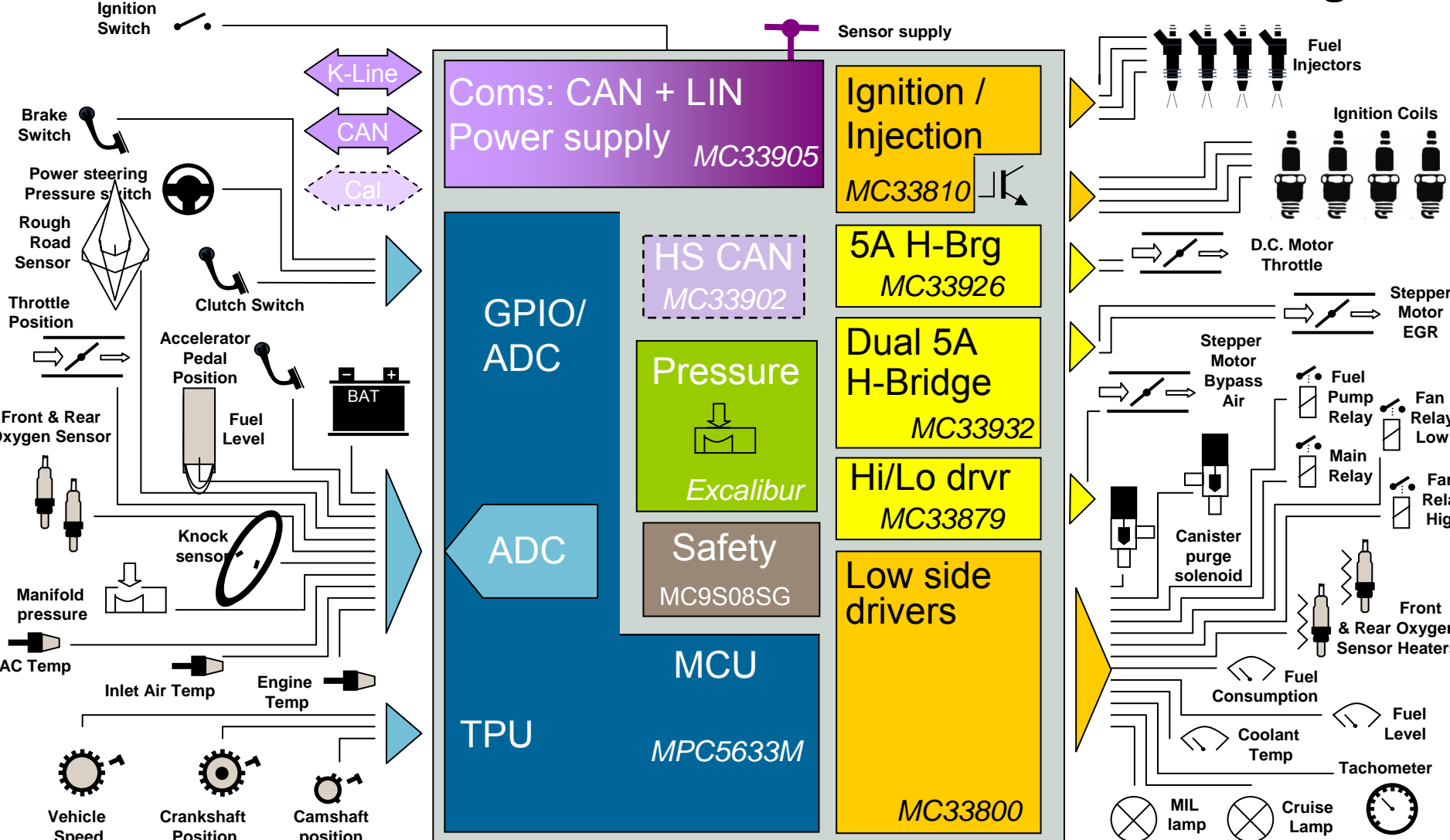

MPC563xM Engine Control Unit Components

- ▶ MPC563xM Power Architecture MCU
 - System control
- ▶ S08SG8 8-bit MCU
 - Safety MCU - Redundant signal capabilities
- ▶ MC33905 System Basis Chip
 - 5V power supply
 - CAN driver
 - LIN driver
 - K-Line driver
- ▶ MC33810 4-Cylinder Ignition/Injection Driver
 - Ignition drivers (spark plugs)
 - Injection drivers (injector solenoids)
- ▶ MC33926 5A H-Bridge
 - DC motor (throttle control)
- ▶ MC33932 Dual 5A H-Bridge
 - Stepper motor for control of exhaust gas recirculation (EGR)
- ▶ MC33879 High/Low Side Drivers
 - Alternate control for ETC
- ▶ MC33800 Low Side Drivers/Octal Switch
 - Controls relays, fuel pump, coolant temperature monitor, coolant fan, oxygen sensor heater control, etc.

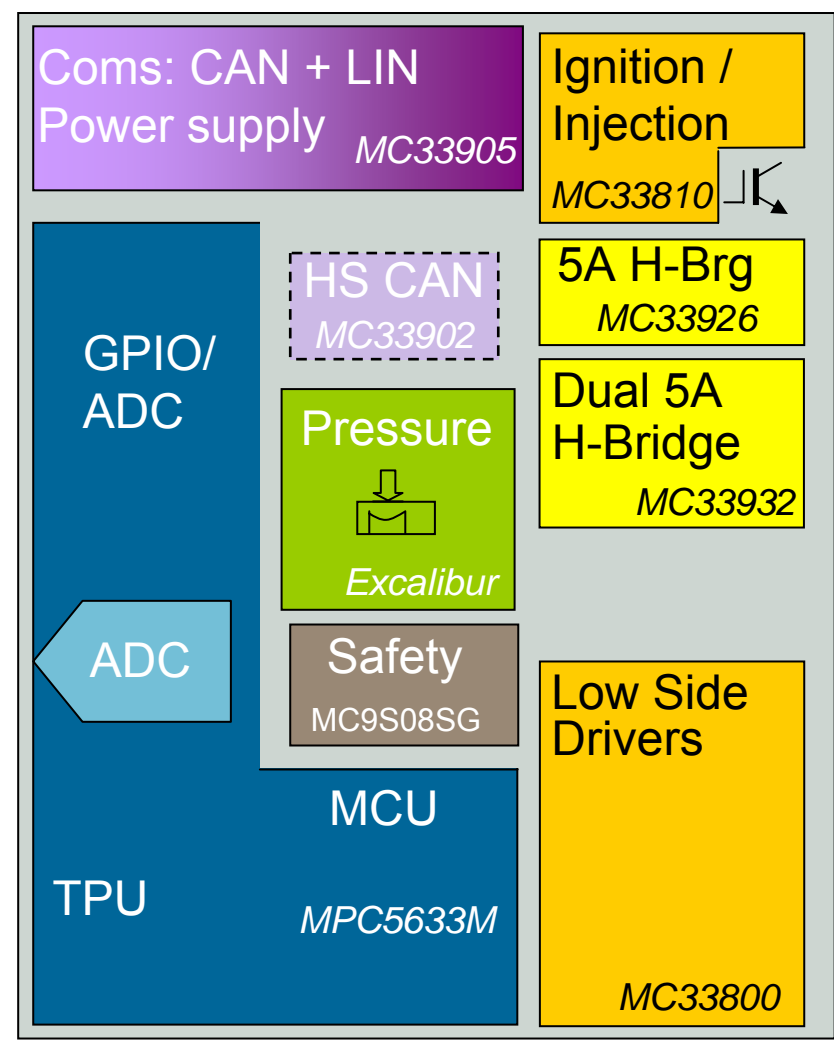



Agenda

- ▶ Session objectives
- ▶ System block diagram and overview
- ▶ **MPC563xM powertrain advantages and overview**
- ▶ Secondary safety MCU
- ▶ SmartMOS devices
- ▶ Pressure sensor
- ▶ Software drivers and libraries
- ▶ Mechanics
- ▶ Summary



MPC5634M ECU Block Diagram

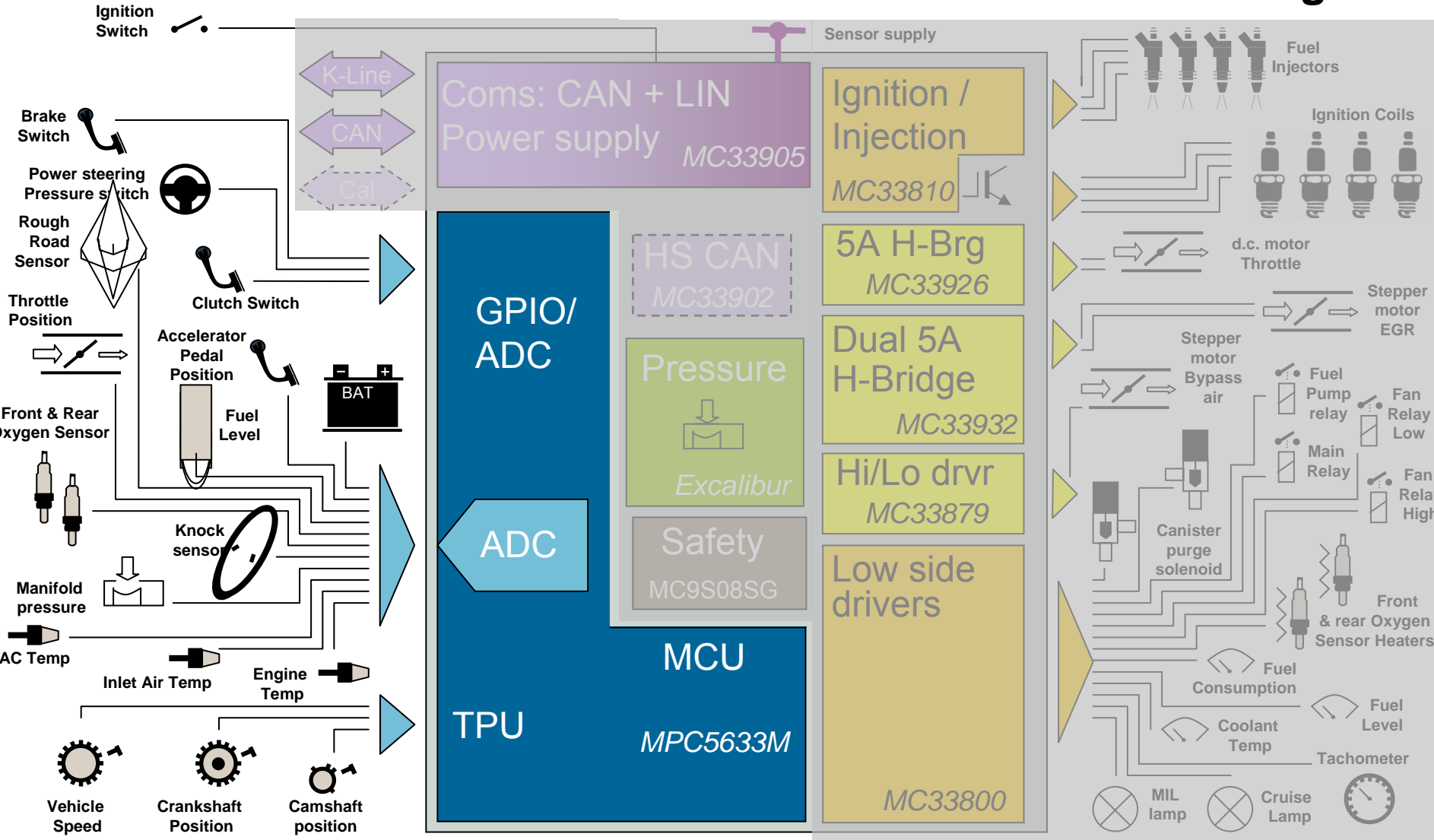

- ▶ 70, 80 and 80 MHz options PowerPC™ ISA e200z335 Core + VLE
 - Binary user mode compatible with RCPU (MPC500) and e200z6
 - Signal Processing Engine for DSP and floating point features
 - Variable Length Encoding instruction set supports smaller code size
 - EABI Interrupt instructions
 - 16-entry Memory Management Unit

Memory

- ▶ 1.5 Mbyte RWW Flash with ECC
- ▶ 111k SRAM
 - 94k Data RAM (also has 32K/24K for standby) with ECC
 - 17k for eTPU2 (14k code & 3k parameters)

I/O

- ▶ Timed I/O Channels
 - 32 channel eTPU2
 - 16 channel eMIOS
- ▶ 2 x FlexCAN: 64 + 32 buffers
- ▶ 2 x eSCI
- ▶ 2 x DSPi 16 bits wide up to 6 chip selects each
 - Supports 32-bit Micro Second Bus
- ▶ 34-channel dual ADC : up to 12 bit and less than 1us conversions, 6 queues with triggering and DMA support.
 - Variable gain amplifier (X1, X2, X4)
 - Decimation filter (4th order IIR or 8th order FIR with prog.coeff.)
 - 4 pairs differentials inputs with selectable pull ups and downs

System

- ▶ FM-PLL
- ▶ Junction temperature sensor
- ▶ 32 channel DMA controller
- ▶ Nexus IEEE-ISTO 5001-2003 Class 2+ (eTPU2 Class 1)
- ▶ **Single 5V power supply**
- ▶ EBI for calibration (16bit, CSP only)
- ▶ 144 LQFP package (32 ADC)
- ▶ 176 LQFP package
- ▶ 208 MAPBGA (no bus, 34 ADC)
- ▶ 496 CSP Calibration Bus (used in VertiCal emulation devices)

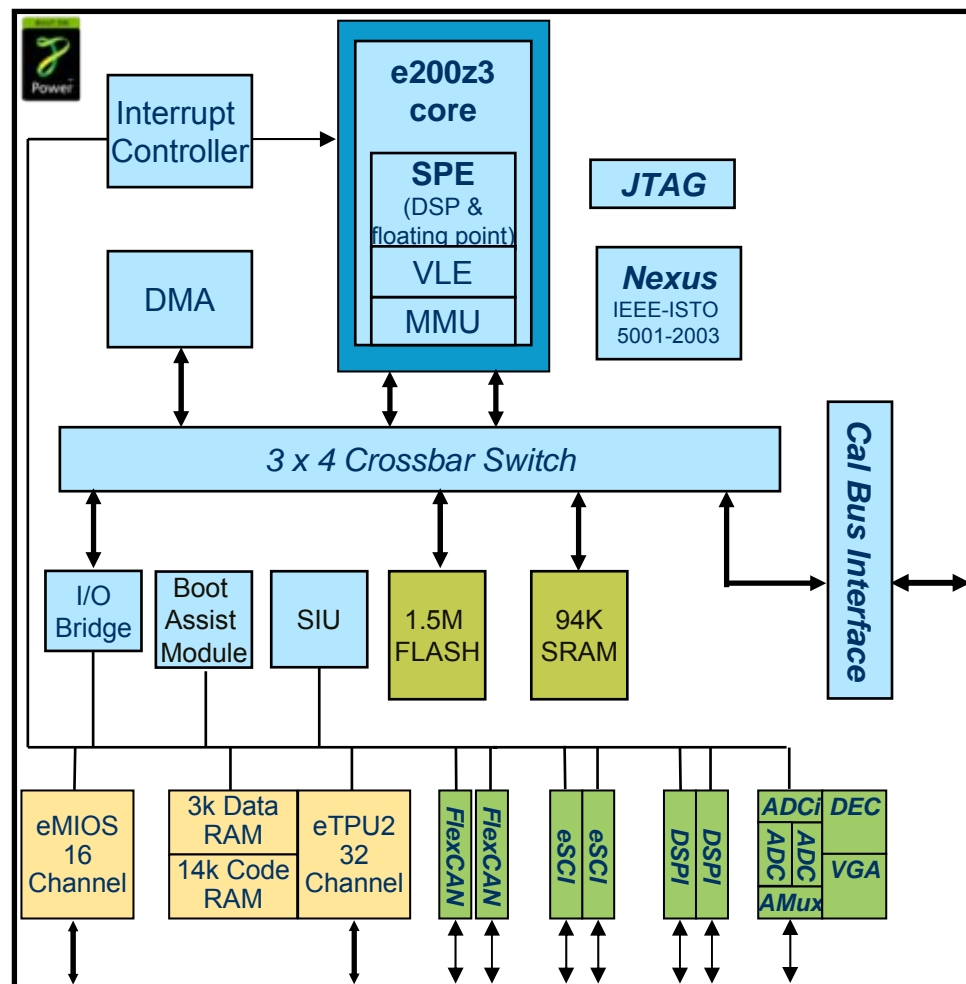

▶ **Designed for entry-level powertrain applications**

- Freescale’s first 32-bit, 90 nm powertrain MCU family built on Power Architecture® technology designed for up to 4-cylinder engines
 - 1–4-cylinder gasoline direct injection engines
 - Entry-level diesel engines
 - Entry-level transmission control

▶ **Enables suppliers to go beyond 16-bit capabilities**

- Code density, includes VLE instruction set
- Flash up to 1.5 MB
- RAM up to 94 KB
- CPU performance up to 80 MHz

▶ **Offers enhanced powertrain functionality such as:**

- On-chip emission control/knock system
- Hardware decimator to offload DSP calculations from CPU
- eTPU2 to handle complex timer applications and offload CPU

▶ **Addresses aggressive cost constraints of emerging markets**

- Engine and transmission suppliers focused on emerging markets
- All global suppliers selling into emerging markets (e.g., China, India)
- All global suppliers selling to entry-level powertrain markets (e.g. Japan, EMEA)



- ▶ Powerful Power Architecture CPU and peripherals
- ▶ 144-lead QFP package (176/208 also available)
- ▶ Features all designed for powertrain, e.g. eTPU, ADC
- ▶ Integrated knock solution eliminates external ASIC
- ▶ Don't need as much optimization of software (to make it fit/run)
- ▶ Floating point support for model-based code
- ▶ Expansion available for flash/RAM
- ▶ Compatible CPU/device/pinout roadmap with headroom
- ▶ Calibration solution developed and available
- ▶ Engine software components developed and available
- ▶ Significant Freescale support/expertise in powertrain on 32-bit

- ▶ 100% compatible with the eTPU used on the MPC55xx Family devices
 - No changes required to hardware or software if only eTPU features are used
- ▶ Supports a wider range of frequencies
 - Supports higher frequency operation and full system clock resolution which is most useful at lower frequencies
- ▶ New channel features
 - Main change is programmable channel modes to provide additional flexibility and control of timer channels
- ▶ New programming features
 - Biggest change is engine relative addressing mode to allow more efficient C code
- ▶ Safety related enhancements
 - New software watchdog and memory error detection features
- ▶ Enhancements for motor control
 - This is not a change to the eTPU itself but a change in integration
 - More eTPU channels have separate input and output signals to allow an eTPU to control 4 BLDC motors

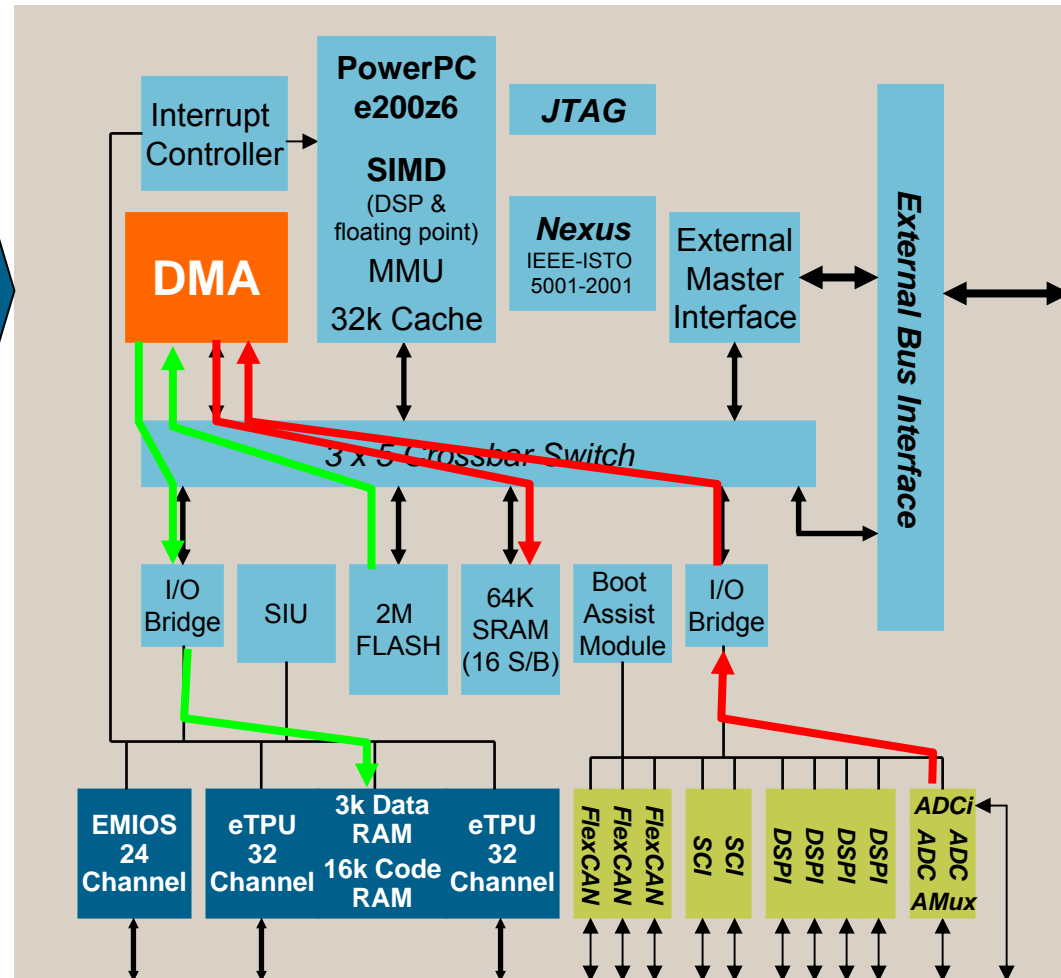
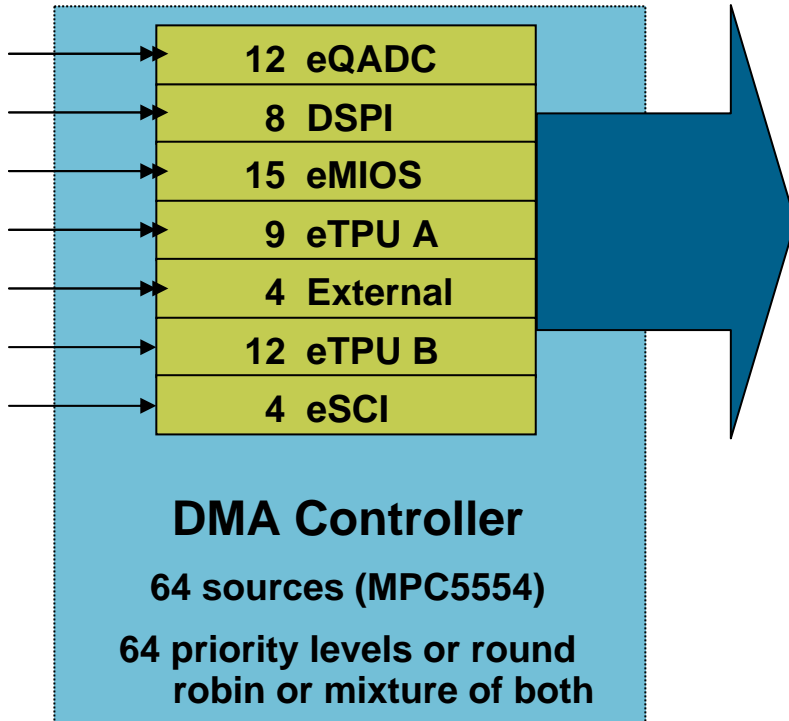

For more information, attend the following session:
 FTF-AUT-F0451 Tips and Tricks with DMA on MPC56xx

Enhanced Time Processor Unit: eTPU

- ▶ A programmable 32 channel timer and angle co-processor
 - ▶ Performs complex timing and I/O management without CPU intervention
 - Scheduler allows service of EVENT requests
 - Fuel injection example follows EVENT flag requests service
- Channel hardware changes pin due to timer match. It is also programmed as an EVENT

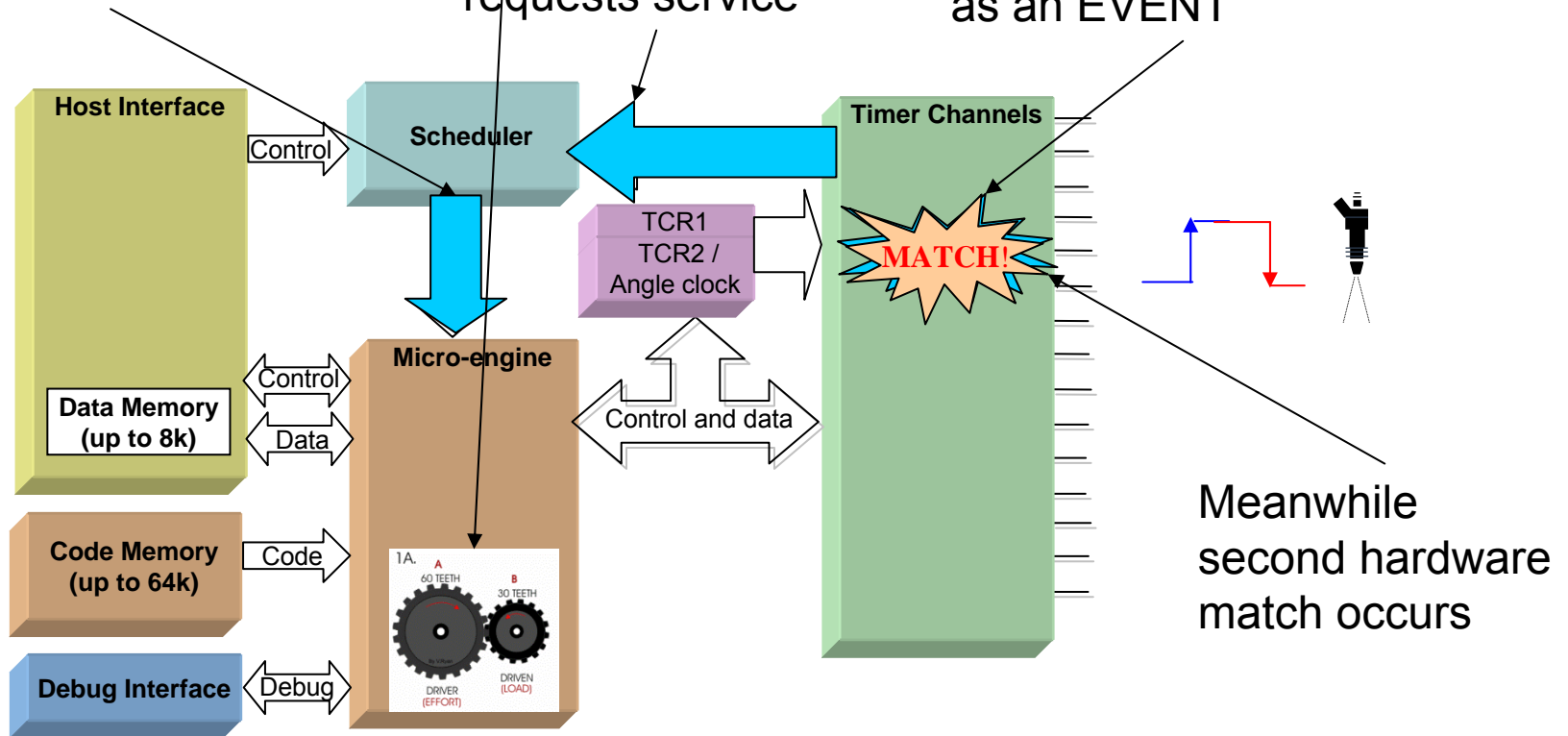

For more information, attend the following session:
 FTF-AUT-F0447 Using Enhanced Time Processing Unit (eTPU/eTPU2) for Combustion Engine Management and Electric Motor Control

Microengine reads THREAD of code for this EVENT only

Microengine reads updated time match

Microengine writes updated time match to channel hardware

Microengine now waits for next EVENT from Scheduler

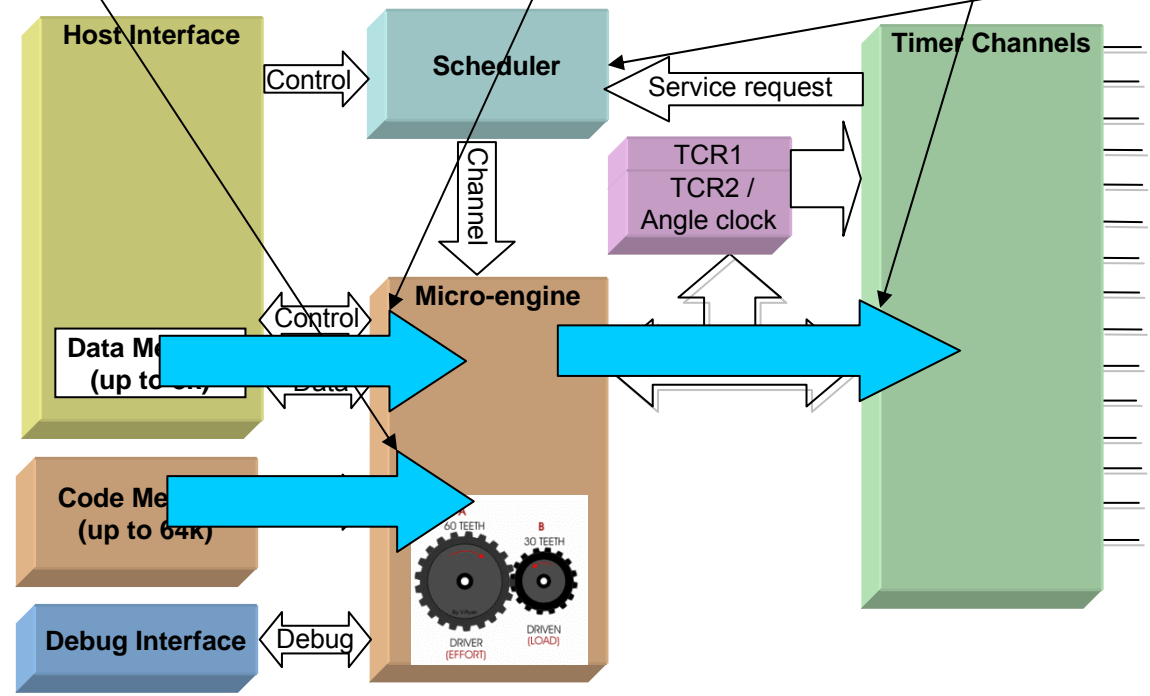

- ▶ Two independent on-chip ADCs
- ▶ 12-bit resolution
- ▶ 1µs conversion time
(1 M sample/second) for 12-bit differential result
- ▶ 1.06 us for 12-bit single ended result
- ▶ 10-bit and 8-bit conversions for up to 1.4 M sample/second
- ▶ Sample times of 2 (default), 8, 64 or 128 ADC clock cycles
- ▶ Single-ended signal range from 0 to 5V
- ▶ Variable gain amplifier for X1, X2, X4
- ▶ 40 single ended channels available to both ADCs in 324BGA and 416BGA
- ▶ 34 channels in 208BGA
- ▶ 4 pairs of differential analog input channels
- ▶ Programmable pull ups, pull downs for each differential input (5k, 100k, 200k)

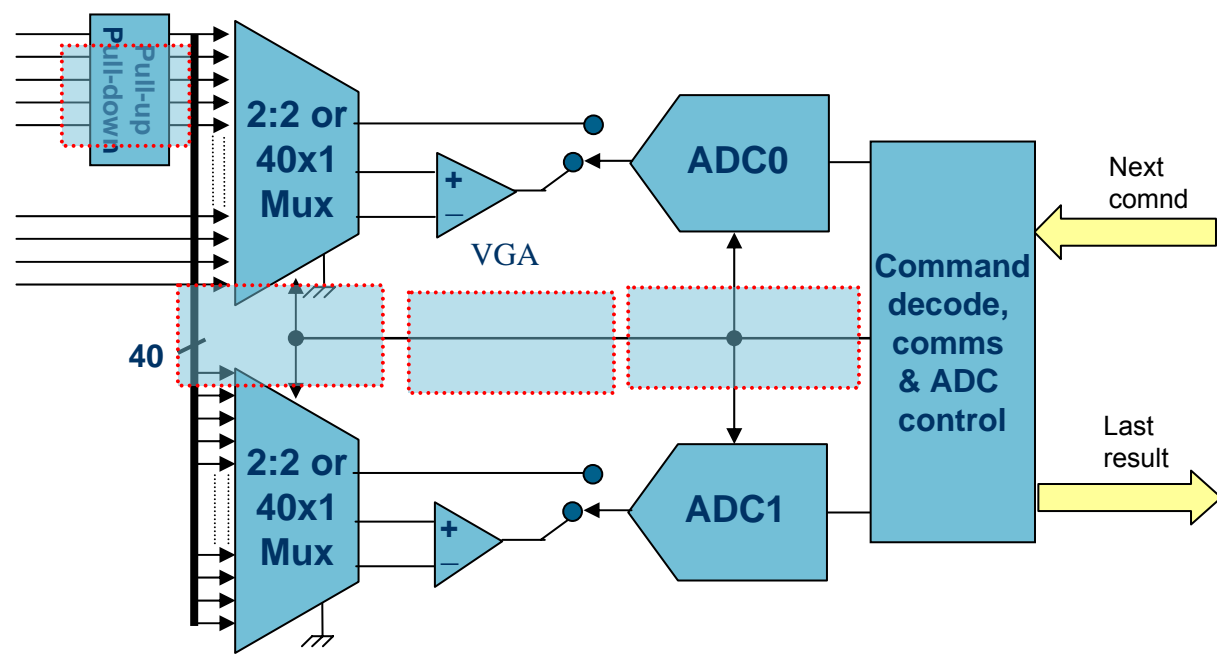

- ▶ CFIFO local buffers: store the next few commands fetched by DMA from command queues
- ▶ CFIFO queue triggers from timers or pins
- ▶ Priority logic: presents the analog block with the next conversion
- ▶ Calibration module: trims results to improve accuracy
- ▶ Decimator: filters a data stream, can downsample, rectify and integrate
- ▶ DMA: allows decimator to be used as stand alone filter
- ▶ RFIFO local buffers: stores the last few results prior to DMA transfer to results queues

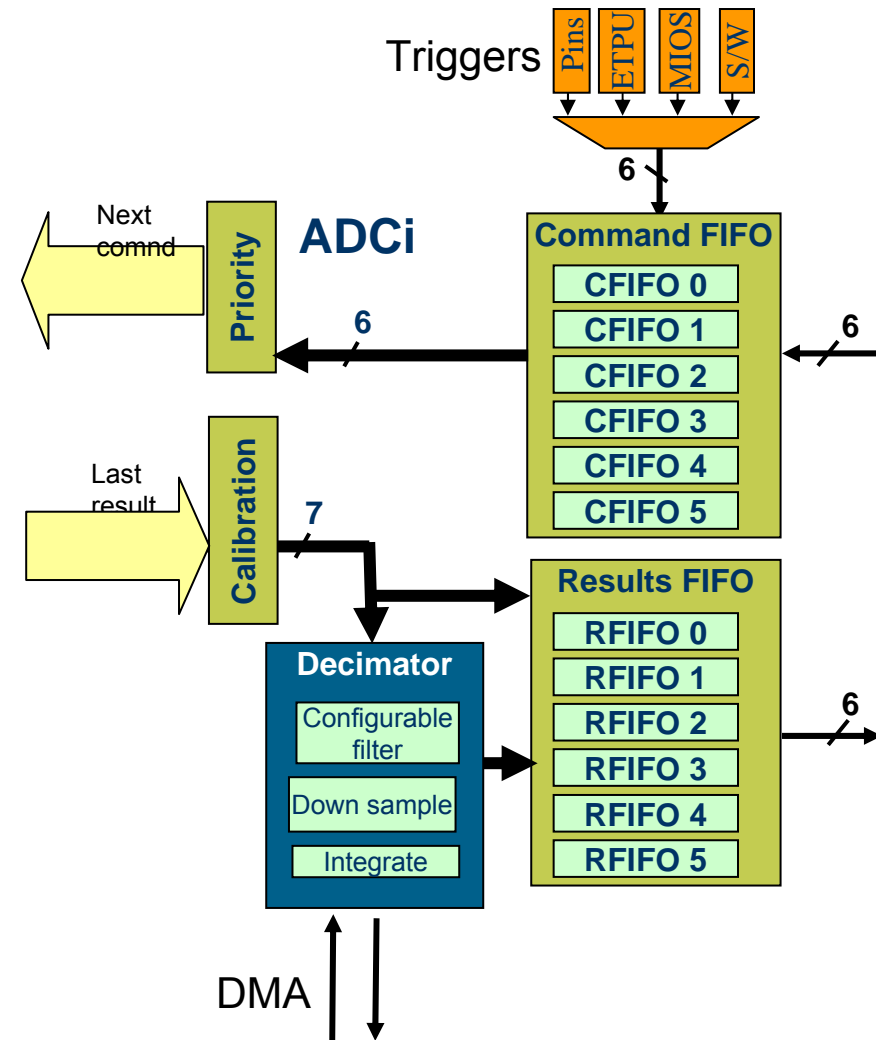

- ▶ 8-bit, 10-bit and 12-bit conversion modes for increased speed
- ▶ Increased conversion speed:
 - 12-bit resolution at 1M samples / sec
 - 1 usec conversion time
 - 8-bit resolution at 1.36M samples / sec
 - 730 nsec conversion time
- ▶ ADC queue 0 preempt for reduced conversion jitter
- ▶ 4 pairs of differential analog input channels
 - Variable gain amplifier for X1, X2, X4
 - Programmable pull ups, pull downs for each diff. input for piezo sensor diagnostic
- ▶ Configurable decimation filter
- ▶ Custom calibration variables
- ▶ Queue triggers from PIT
- ▶ ADC streaming without commands

Software DSP Solution using MPC563xM

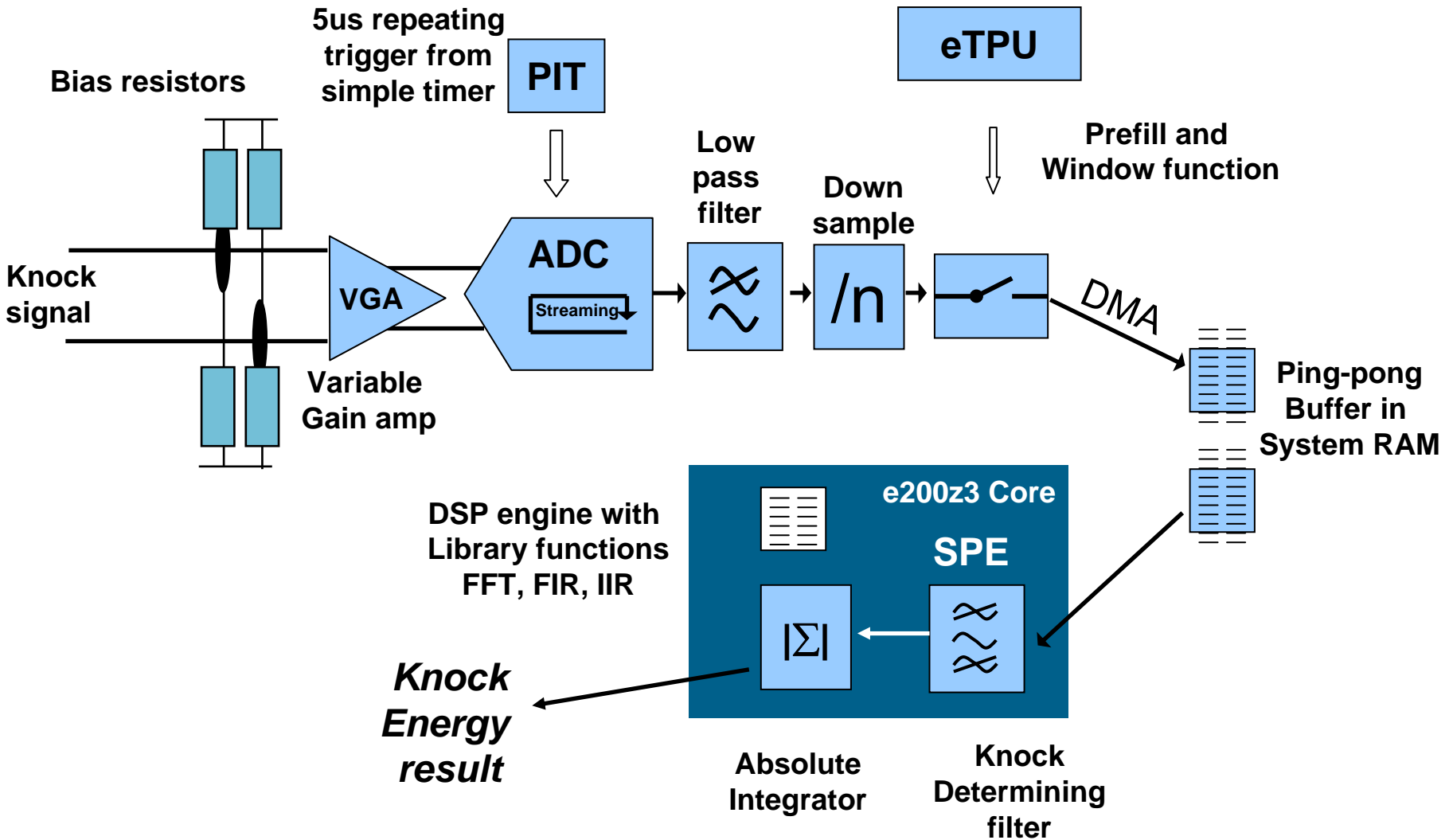

For more information, attend the following session:
 FTF-AUT-F0354 Reducing System Cost with Integrated MCU Solutions for Engine and Transmission Applications

Power Supply Monitor ADC Channels

- ▶ Internal ADC channels for monitoring power supply voltages for diagnostic purposes
- ▶ Temperature sensor accuracy of +/- 10C

Channel	ADC	MPC553xM Definition
128	ADC0/ADC1	Temperature Sensor
144	ADC0	Buffered Band Gap
145	ADC0	Reference Voltage for 1.2V LVD
146	ADC0	Reference for 1.2V Regulator
147	ADC0	Reference Voltage for 3.3V LVD
162	ADC0	50% VDDEH1B
163	ADC0	50% VDDEH1B
164	ADC0	50% VDDEH6A
165	ADC0	50% VDDEH6A
166	ADC0	50% VDDEH6B
167	ADC0	50% * VDDEH7
180	ADC0	Reference Voltage for 5.0V LVD
181	ADC0	Reference Voltage for 3.3V LVD
182	ADC0	Reference for 3.3V Regulator
196	ADC1	VRC33
197	ADC1	VRC33
198	ADC1	VDD12
199	ADC1	50% VDDEH1A

- ▶ Provides various hardware timing modes to create or measure real-time signals
- ▶ 32 channels, 24 bit resolution, 200 MHz max operation
- ▶ Programmers model is consistent with MPC5500 family eMIOS implementations
- ▶ Programmable clock prescalers (global and per-channel)
- ▶ DMA request for each channel
- ▶ Programmable input filter
- ▶ Channels can be individually disabled to assist with power saving
- ▶ Four channels provide high speed hardware shut-down of other timed I/O
 - e.g. to shut down power drivers in the event of over current or temperature

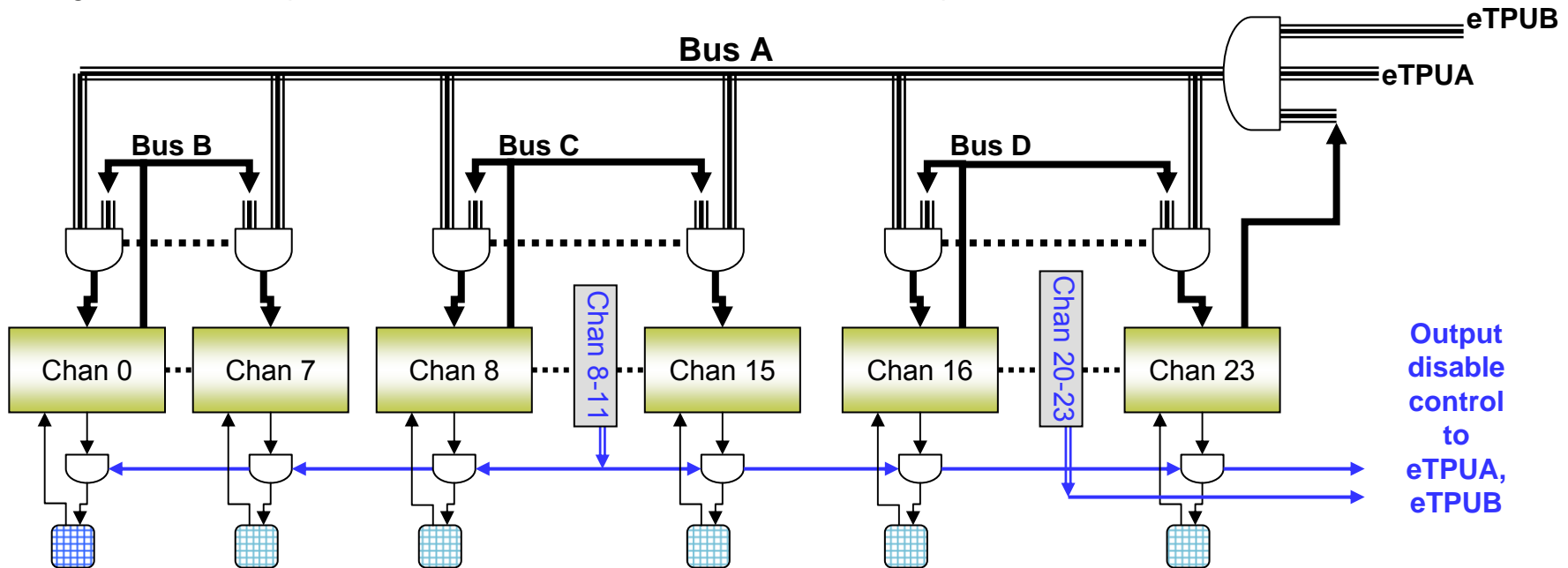

Channel Type	GPIO	SAIC	SAOC	OPWMB	IPM	IPWM	DAOC	OPWFMB	MCB
Small	X	X	X						
Medium	X	X	X	X					
Big	X	X	X	X	X	X	X	X	X

- GPIO - General purpose input/output
- SAIC - Single Action Input Capture
- SAOC - Single Action Output Compare
- IPM - Input Period Measurement
- IPWM - Input Pulse Width Measurement
- MCB - Modulus Counter Buffered
- DAOC - Double Action Output Compare
- OPWFMB - Output Pulse Width and Frequency Modulation Buffered
- OPWMB - Output Pulse Width Modulation Buffered

- ▶ **Generates** a simple output PWM signal
 - Requires **INTERNAL** Counter
 - EDPOL allows selection between active HIGH or active LOW duty cycle.

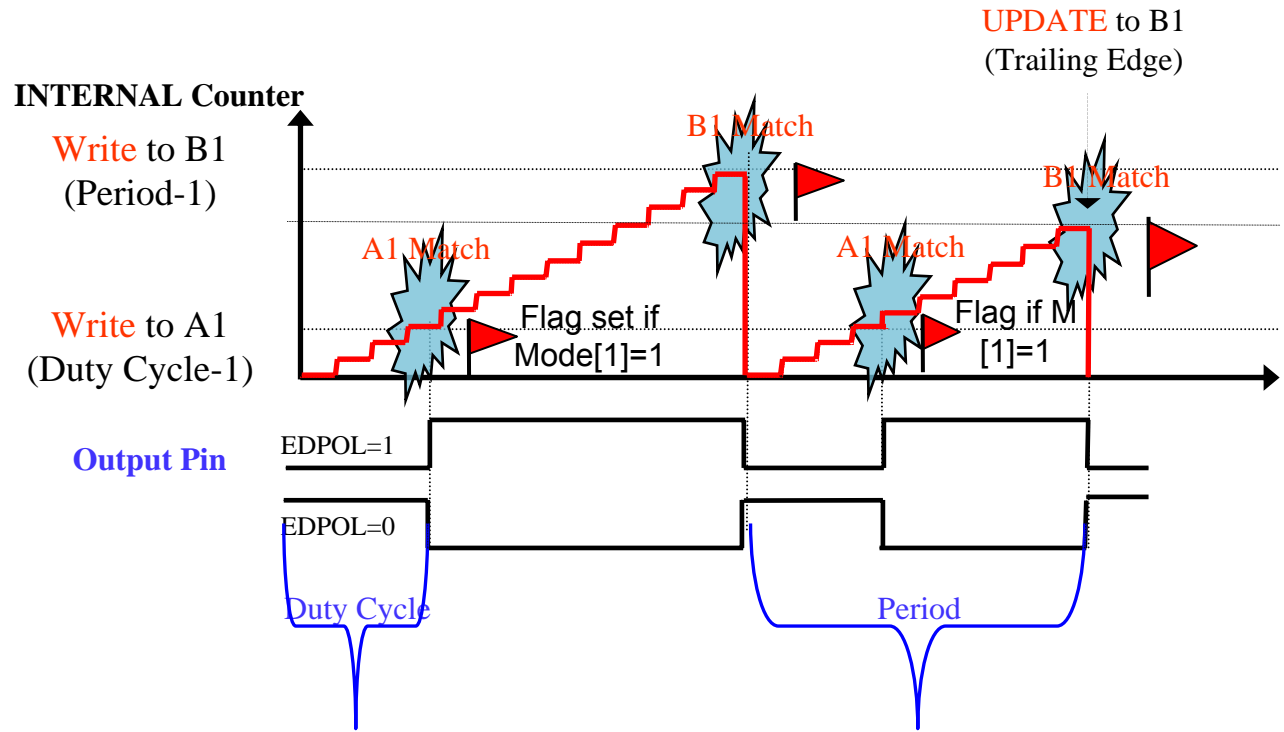

- ▶ eSCI – Provides serial communications such as LIN, K-Line and RS232
 - Two modules are available in the MPC563xM
 - Only one (eSCI_B) is used in the demo ECU for K-line (driver built into the MC33905)
- ▶ FlexCAN – Controller Area Network interface provides up to 1 Mbps automotive
 - Two modules available in the MPC563xM
 - Both are available in the demo ECU. One uses the driver in the MC33905 (CAN_A, 64 message buffers) and is transformer isolated, the other (CAN_B, 32 message buffers) uses the MC33902 driver
- ▶ DSPI – Serial Peripheral Interface (SPI) is used to communicate to the external analog devices, as well as the S08SG8 secondary MCU

VRC: On Chip Voltage Regulator Controller with External Transistor

The VRCCTL pin controls the current on the base of the transistor. Current is increased to raise the voltage on VDD. Current is decreased to lower the voltage. The gain of the transistor controls the maximum current available on VDD from the 5.0V supply.

VDDSense is compared to an internal reference.

The 1.1 ohm series collector resistor is not required in most cases.

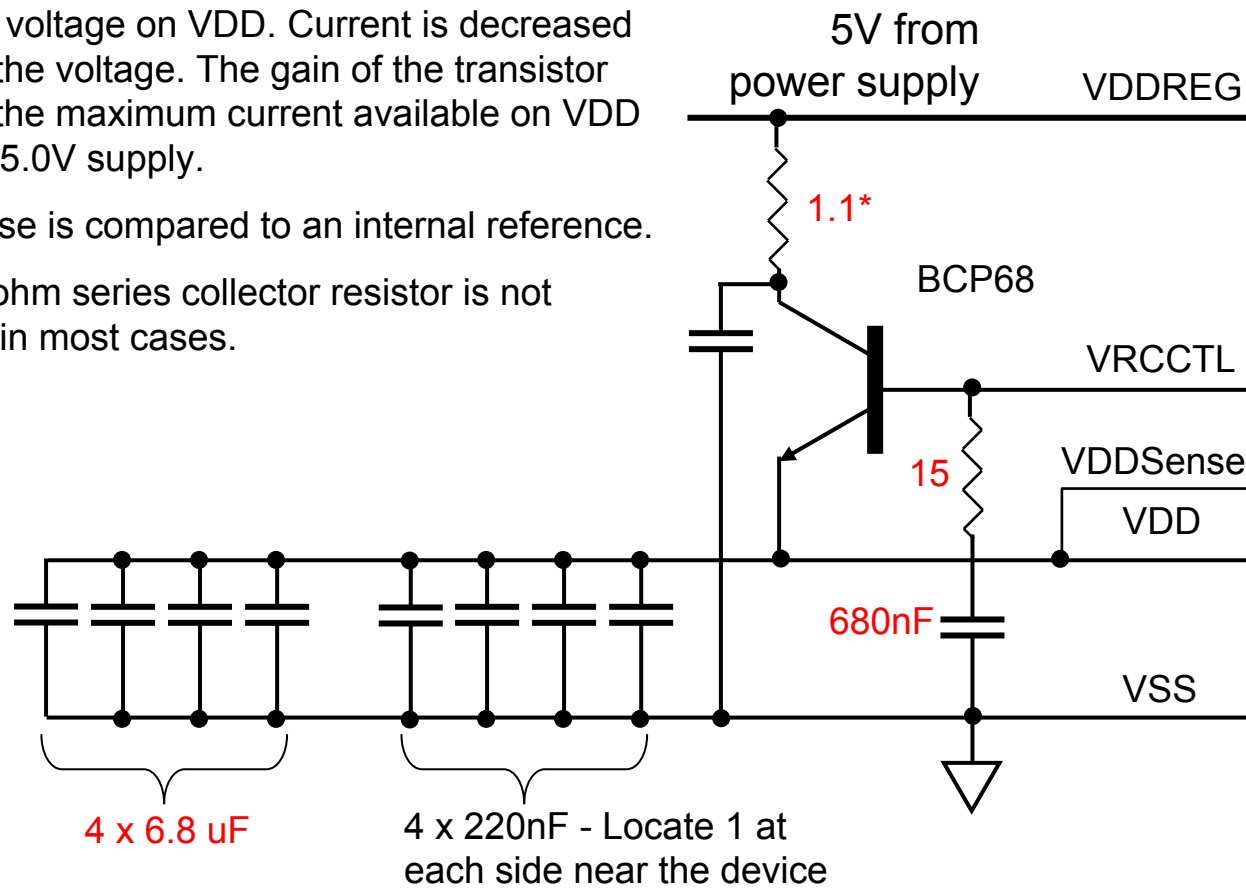

MPC563xM

VDDSense is internal to the package and is not a separate pin on the package.

Frequency Modulation PLL

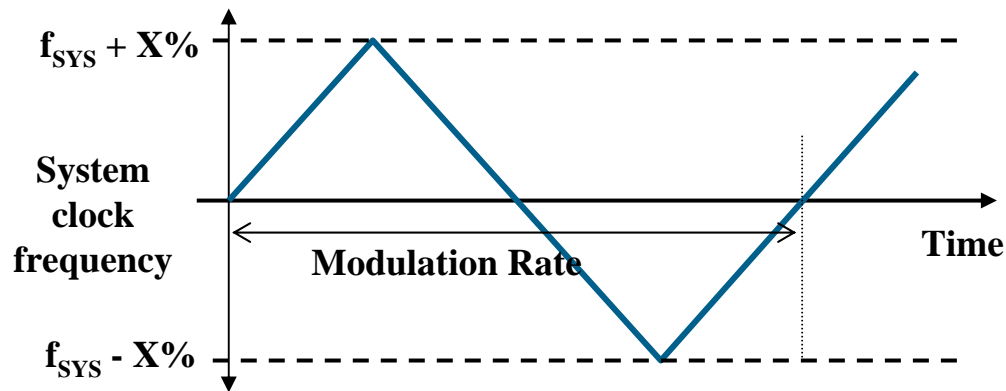
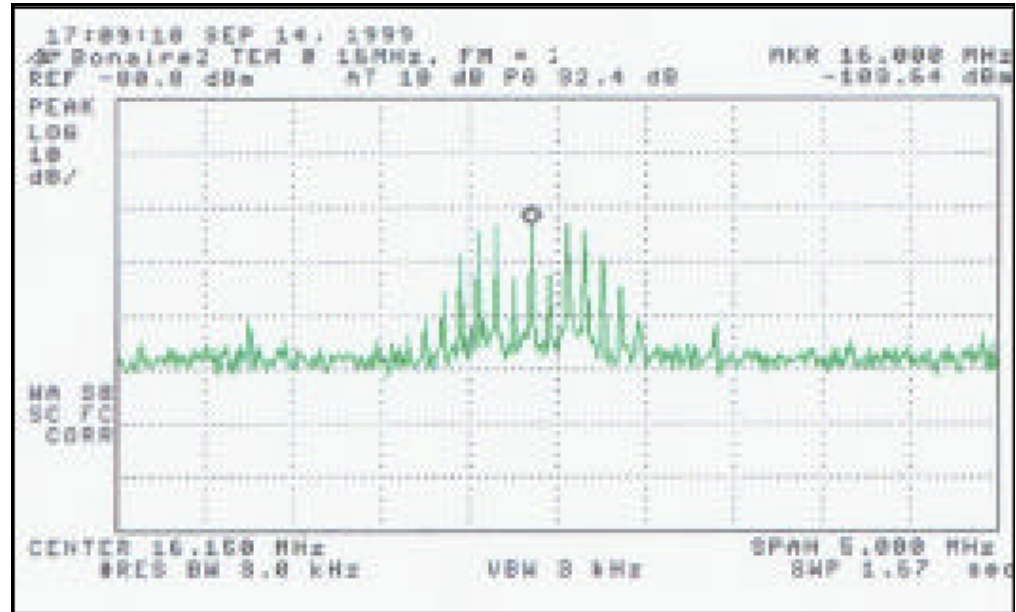
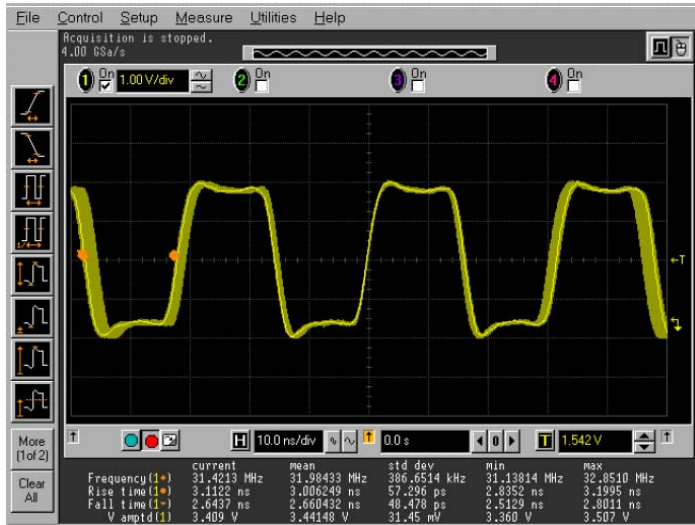

2% modulation

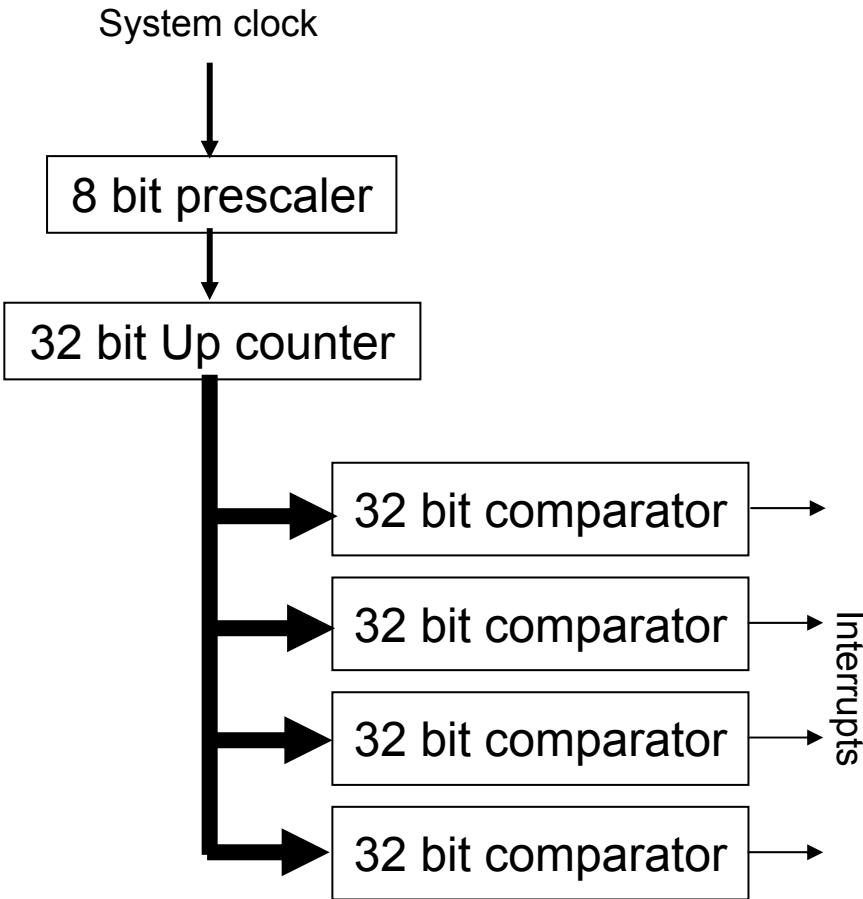

- ▶ AutoSAR Task Monitor timer
- ▶ 1 x 32 bit up counter
- ▶ 8 bit prescale from system clock (/1 to /256)
- ▶ 4 x independent comparators
- ▶ Each comparator has unique interrupt vector
- ▶ Counter can be stopped during debug mode

Periodic Interrupt Timer (PIT) and Realtime Interrupt (RTI)

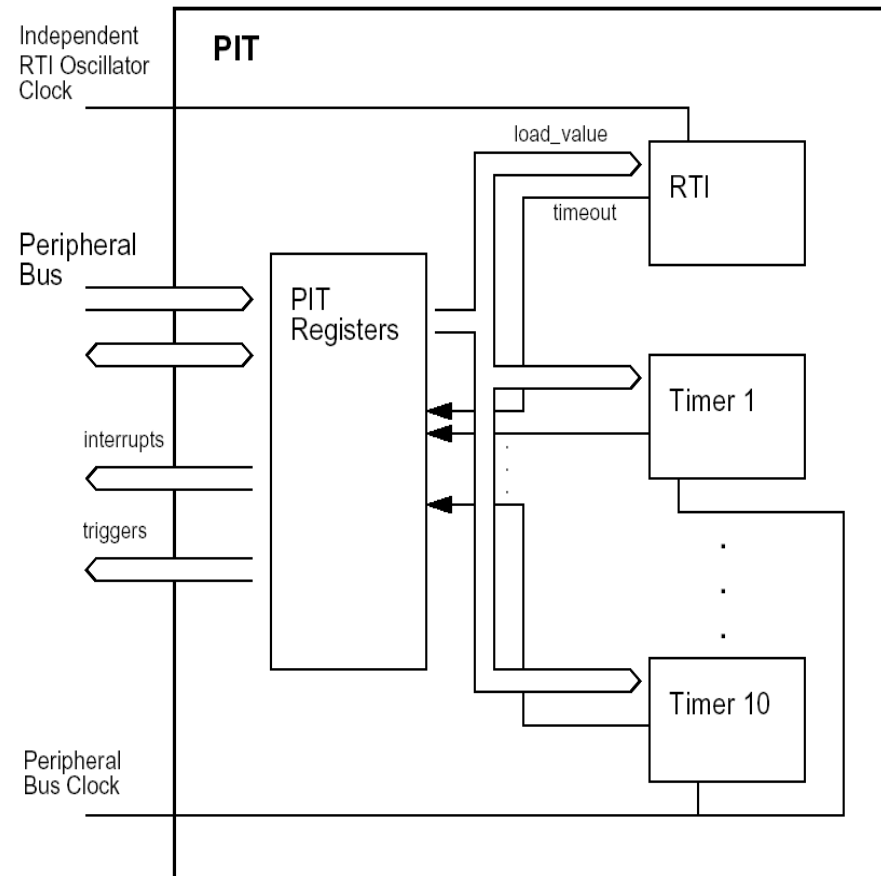

- ▶ 5 timer channels down counting with auto reload
- ▶ 32 bits wide
- ▶ 4 channels clocked by system clock
- ▶ 1 channel clocked by crystal clock
 - Operates in stop mode
 - Used to wake-up CPU
- ▶ Interrupt and trigger on each channel
 - Ideal tick source for operating system
- ▶ Channel outputs can trigger eQADC queues



Agenda

- ▶ Session objectives
- ▶ System block diagram and overview
- ▶ MPC563xM powertrain advantages and overview
- ▶ **Secondary safety MCU**
- ▶ SmartMOS devices
- ▶ Pressure sensor
- ▶ Software drivers and libraries
- ▶ Mechanics
- ▶ Summary



MPC5634M ECU Block Diagram

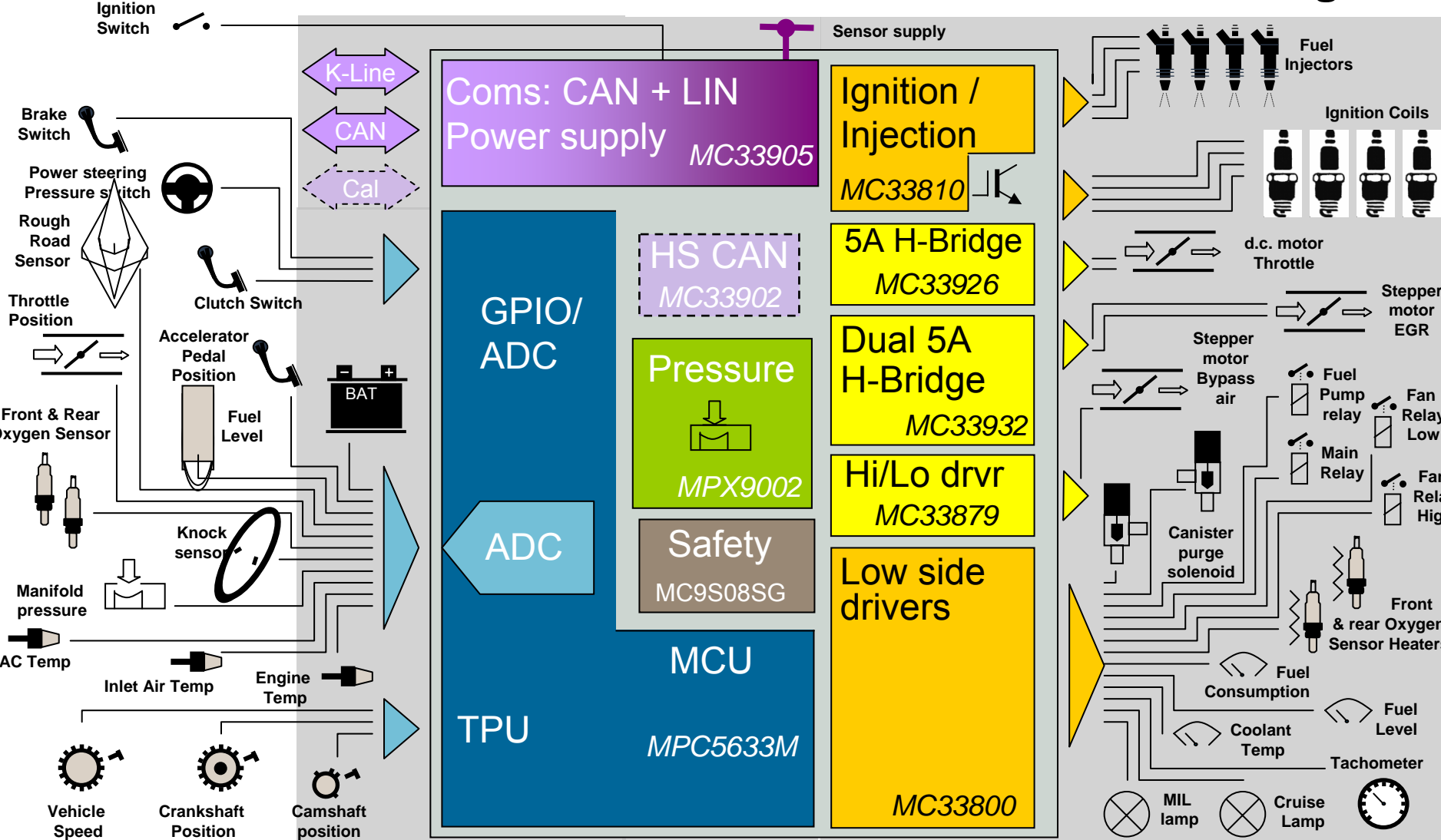

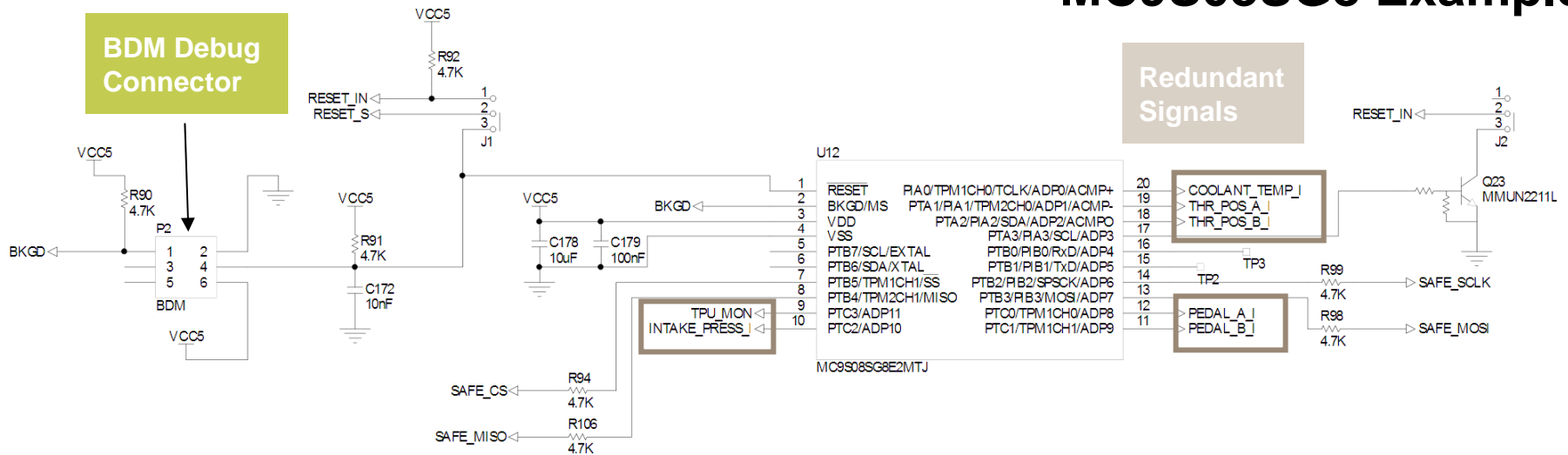

► Redundant signals to both main MCU and secondary MCU allows secondary MCU to calculate in parallel

- Coolant_Temp_I (analog signal) – Temperature of the “engine”
- THR_POS_A_I (analog signal) – Throttle Control A
- THR_POS_B_I (analog signal) – Throttle Control B
- PEDAL_A_I (analog signal)
- PEDAL_B_I (analog signal)
- INTAKE_PRESS (analog signal) – Intake pressure

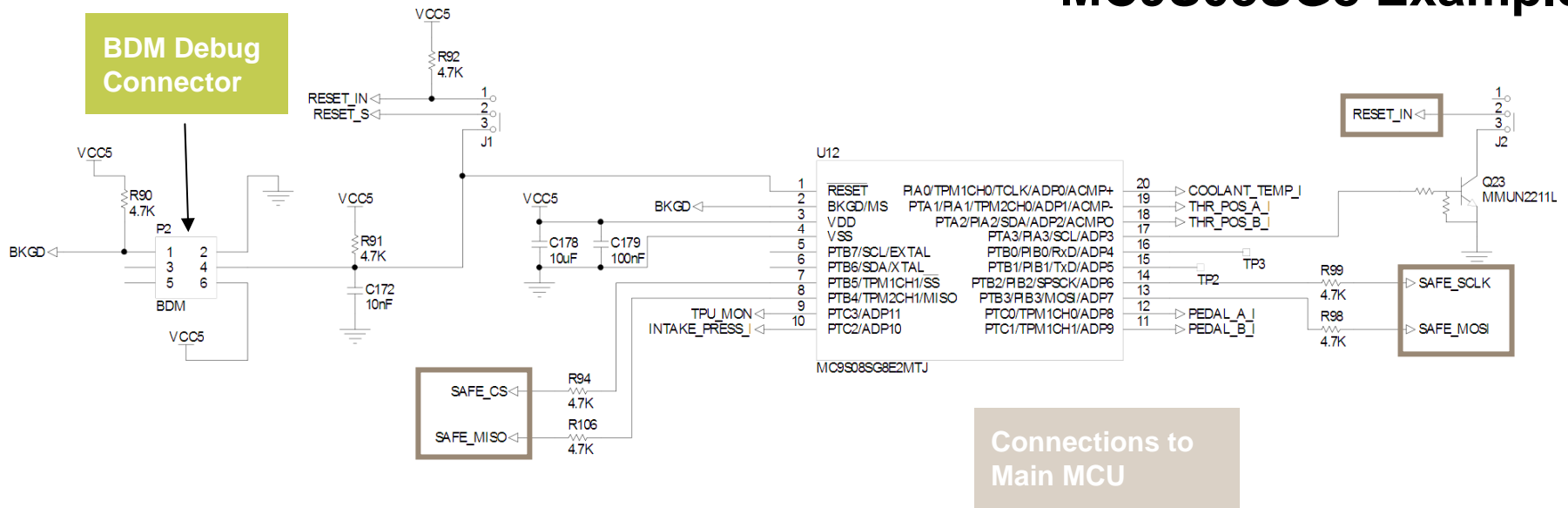

► Connections between MCUs

- TPU_MON allows secondary MCU to monitor some activity on the eTPU
- SPI interface
 - Connected to DSPI_B
 - Can be used to communicate challenge response and for comparing results based on the sensor inputs to both devices
- Secondary MCU can drive reset of the main MCU



Agenda

- ▶ Session objectives
- ▶ System block diagram and overview
- ▶ MPC563xM powertrain advantages and overview
- ▶ Secondary safety MCU
- ▶ **SmartMOS devices**
- ▶ Pressure sensor
- ▶ Software drivers and libraries
- ▶ Mechanics
- ▶ Summary



MPC5634M ECU Block Diagram

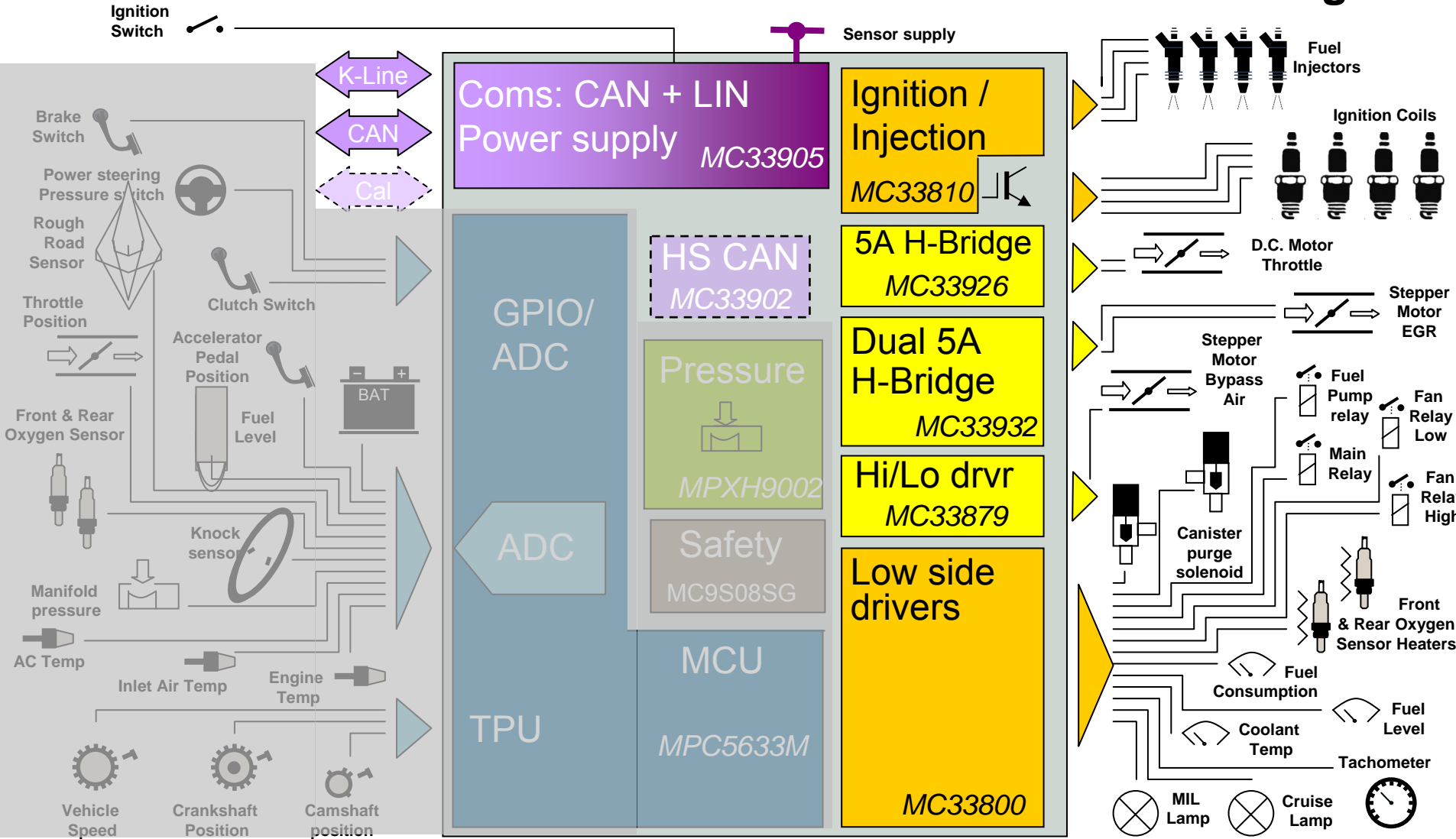

MC33905 System Basis Chip

► Scalability

- Low drop out split regulators for adaptable application power and configuration
- Power sharing to lower thermal effects

► Safety

- Failsafe state machine accessible by SAFE pin
- Secured SPI with watchdog capabilities
- High protection on outputs

► Diagnostics

- Feedback on feature health
- Multiple analog monitoring to MUX output
- High precision VSupply voltage monitoring via SENSE pin

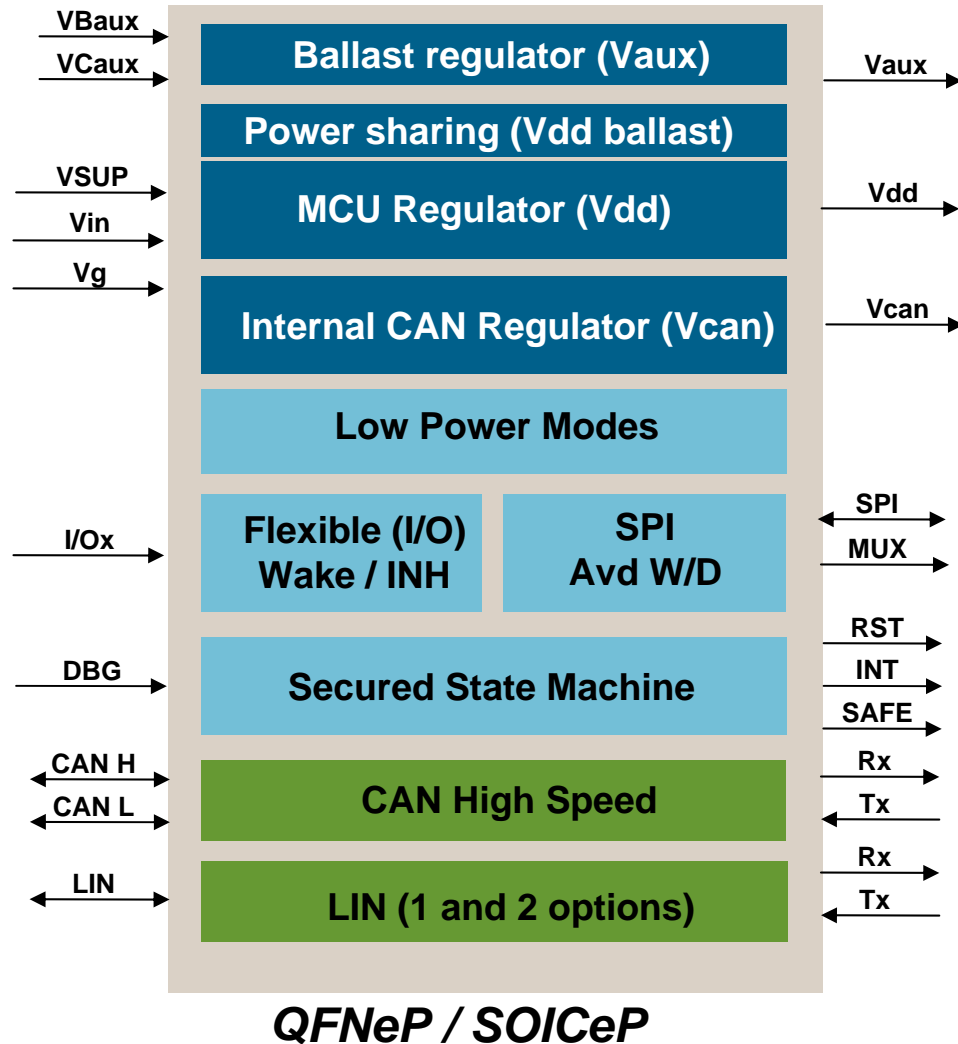

► Energy Savings & Low Power Modes

- Integrated CAN regulator for wake up
- Configurable dual I/O with wake up capability
- Undervoltage management for cranking

► Easy to use

- Software libraries to lower development time

► Flexibility

- 1 or 2 LIN options (905S and 905D)

► Compatibility

- CAN, ISO11898-2 and 11898-5 compliant
- LIN 2.0, 1.3 compliant and SAE J2602 compatible

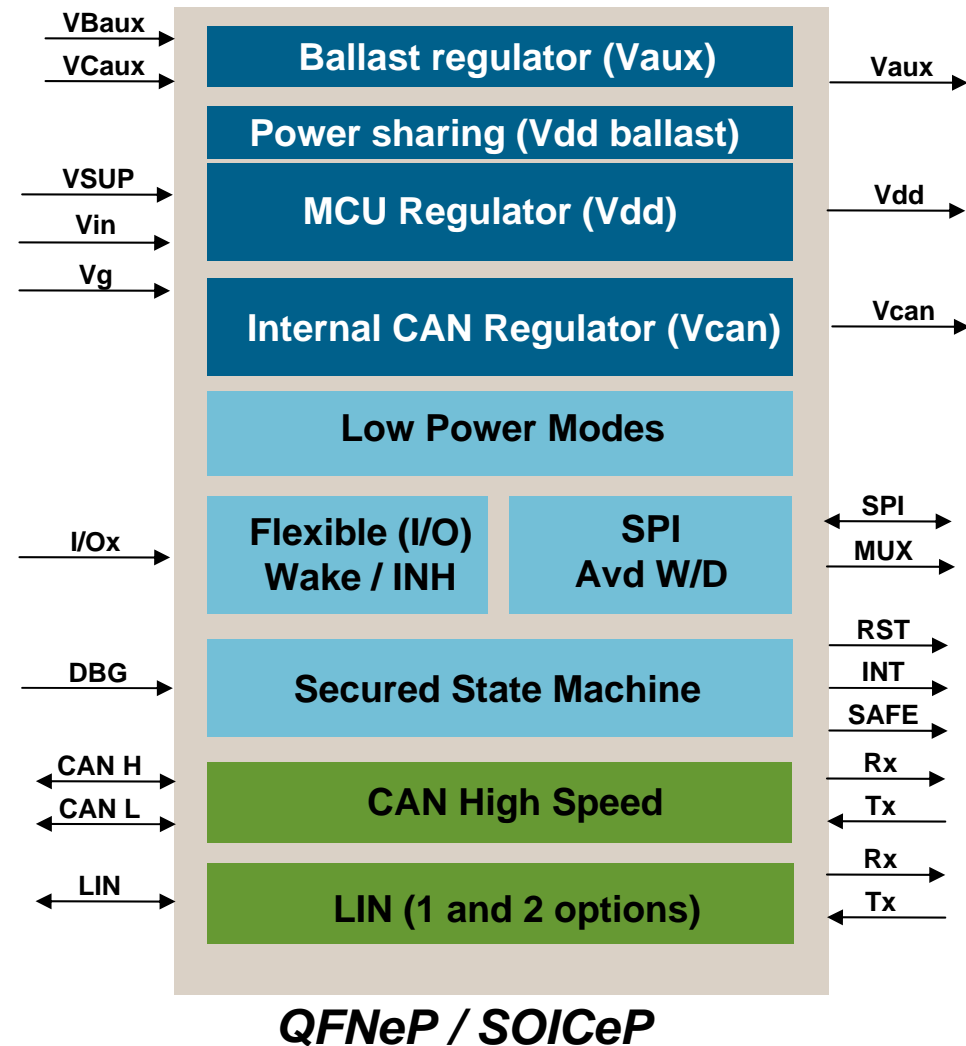

MCU power supply, V_{DD} pin

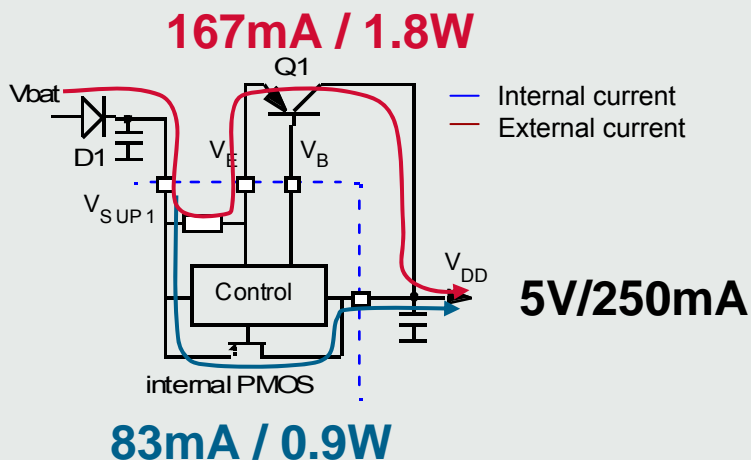

Auxiliary regulator, V_{AUX} pin

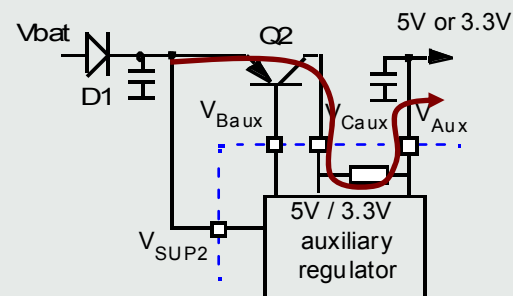

Internal Regulator

- 5.0V / 3.3V option
- Supply up to 150 mA
- LDO +/- 2%

Power Sharing

- *Optional*
- *Derivation of 2/3 I_{VDD}*
- *2/3 power dissipation*
- *Current limitation*
- *Over voltage protect*

Control of External Ballast Transistor

- 5.0 / 3.3 V configurable
- Control of regulation (LDO +/-2%)
- Power dissipation on external PNP
- Current limitation
- Over voltage protect

Example Schematic: MC33905 SBC

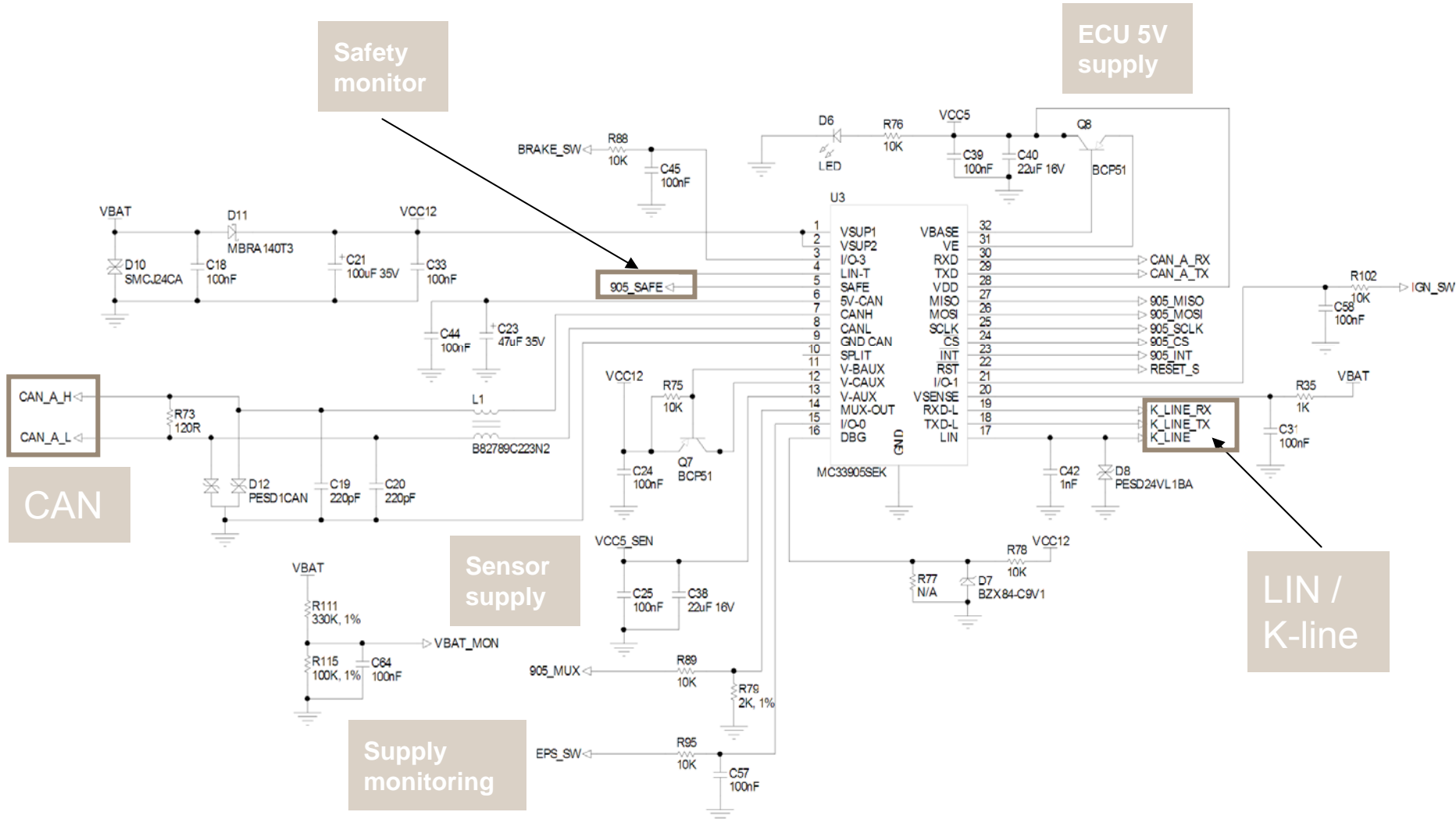

MC33810: Eight Channel Ignition and Injector Driver

► Features

- 8-channels with 4 low-side drivers and 4 pre-drivers
- Pre-drivers with three different modes:
 - Ignition
 - General purpose gate drive
- 2 devices can support up to ten cylinders
- Ignition current and spark detection with programmable thresholds
- MCU SPI and parallel interface
- Power supply/oscillator/band gap reference/POR
- Diagnostic and error detection logic
- Self protection for:
 - Shorts to battery
 - Over current and over temperature detection
- Low power (30 μ A) "sleep mode"

► Benefits

- Highly integrated solution minimizes the need for additional external discrete components
- Reduced parts count
- Reduced manufacturing and test cost
- Improved reliability
- Reduced current consumption lowers battery drain during key off
- Small footprint, reduces printed circuit board area
- Simple MCU parallel interface
- Protected against common failure conditions

MC33810 - Functional Block Diagram

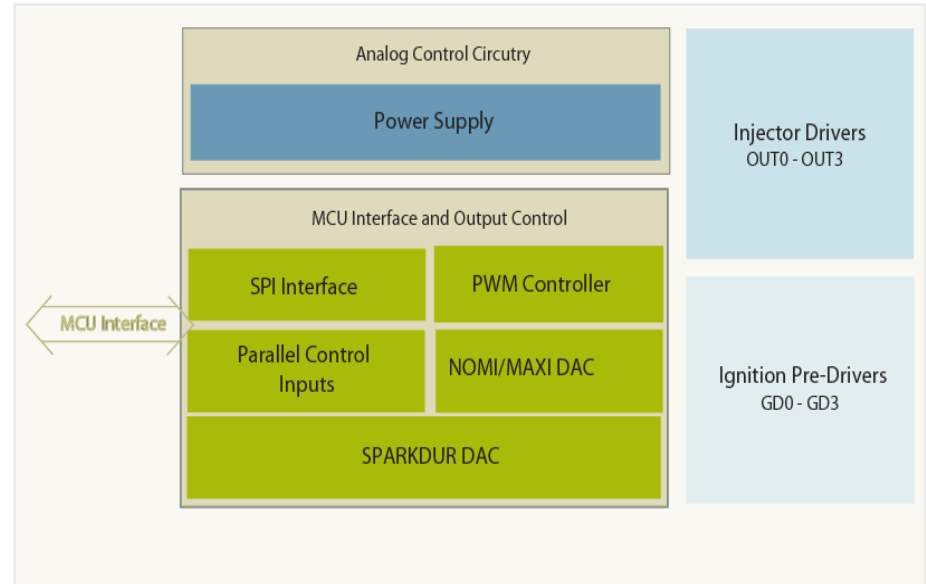

**EK (Pb-FREE) SUFFIX
32-PIN SOICW EP**

1 to 4 Ignition Pre-Drivers

- ▶ Parallel input only (GIN[1:4])
- ▶ Low voltage clamp
- ▶ Coil current detection
 - NOMI – Nominal current
 - MAXI – Maximum current
- ▶ Max dwell timer
- ▶ Overlapping dwell
- ▶ Spark duration
- ▶ Open secondary detect
- ▶ Only one sense resistor needed per bank
- ▶ Can also be individually selected to be GPGD pre-drivers via SPI

MCU ↔ (GIN1:4)

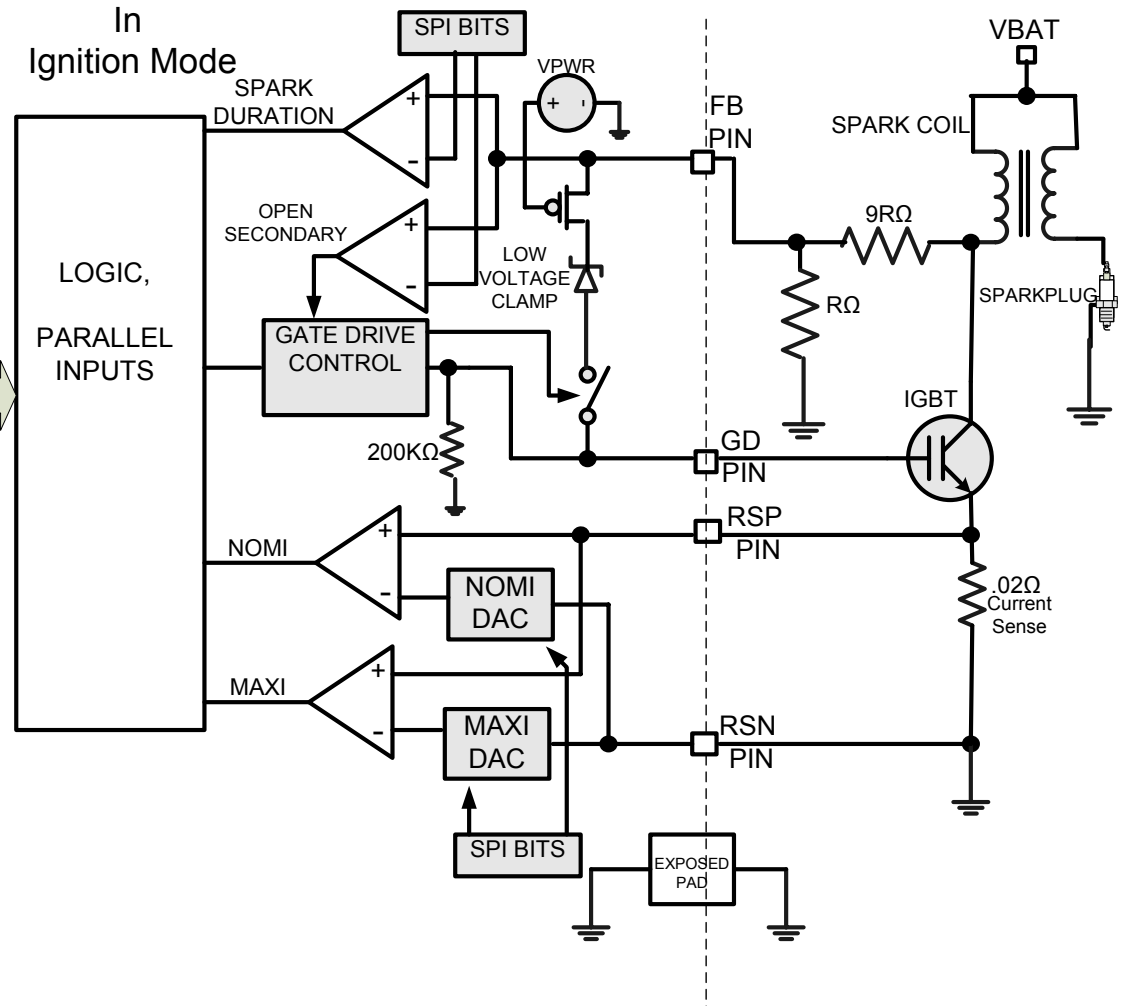

1 of 4 Identical Injector Drivers

Control via SPI or Parallel (INJ[1:4])

Clamp circuit

Open load detect

Over current detection

Over temperature detection

Self-protection by shutdown on over temperature, over voltage, or both.

To Logic Block of MC33810

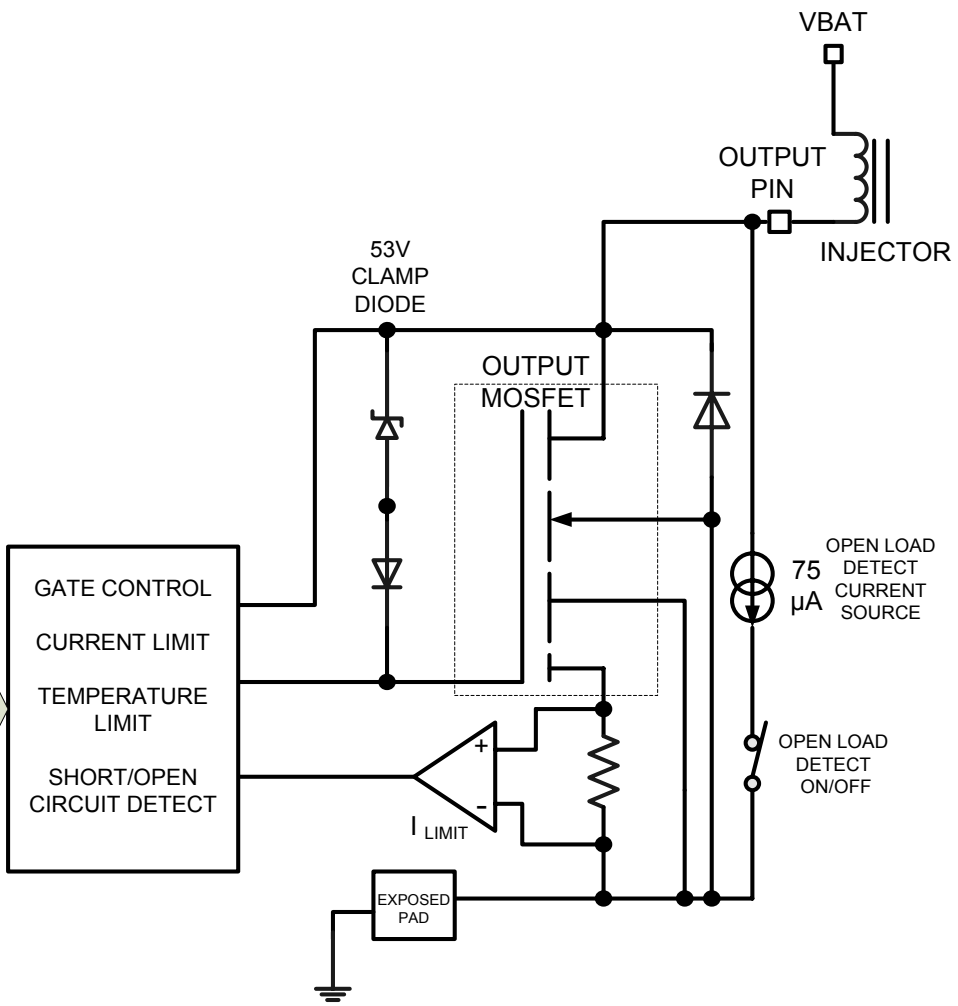
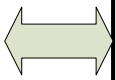

Example Schematic: MC33810 Ignition/Injector Driver

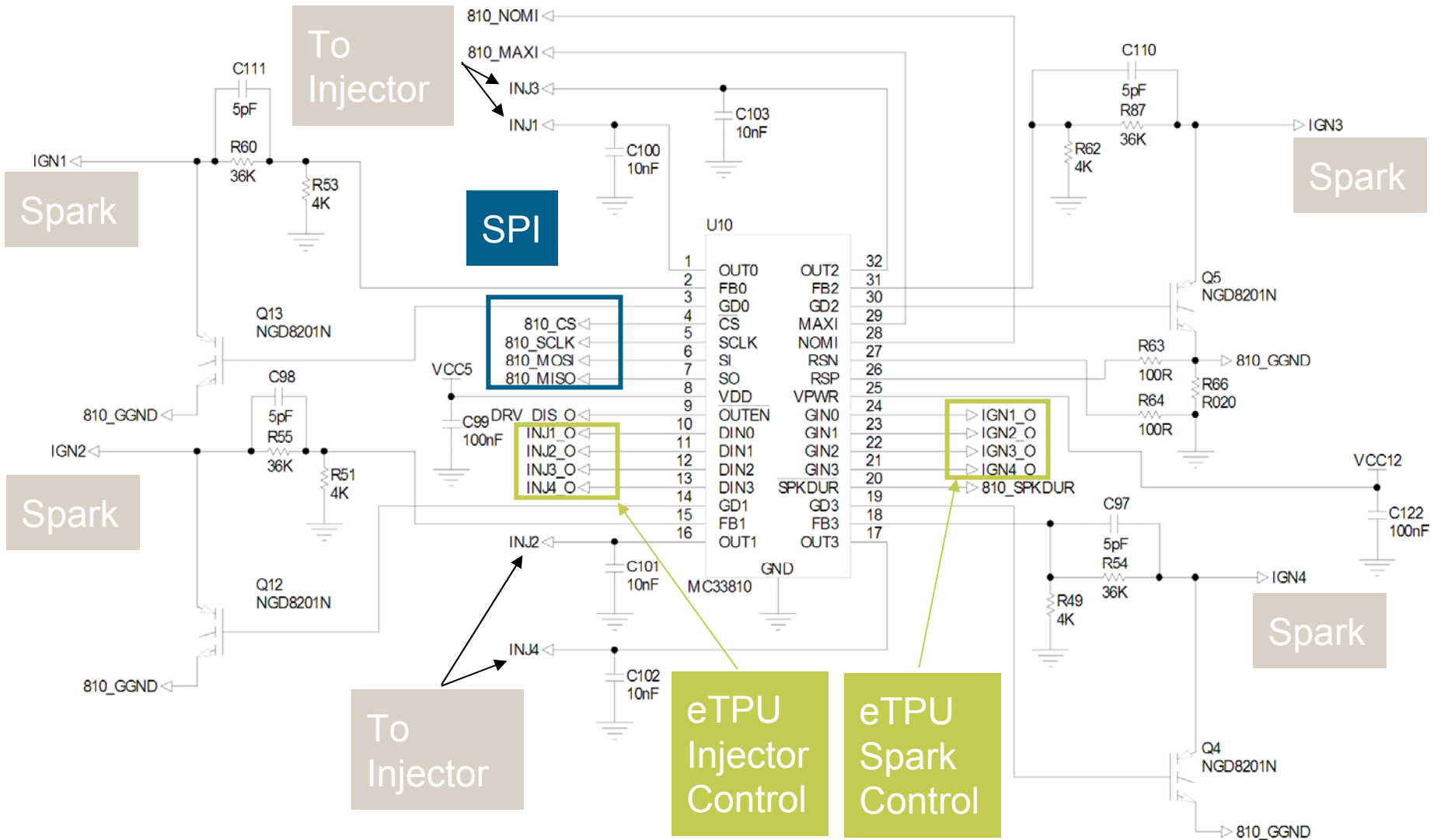

MCZ33800 Multi-Function Driver: Block Diagram

- ▶ Power supply/oscillator/band gap reference/power-on-reset (POR)
- ▶ 8 switches—2 high current (OUTx)
- ▶ 2 constant current drivers with programmable dithering (CCDx)
- ▶ 6 MOSFET pre-drivers (GDx)
- ▶ MCU SPI interface
- ▶ MCU parallel interface
- ▶ PWM generator for pre-drivers
- ▶ Diagnostic and error detection logic
- ▶ Ohmmeter function to measure HEGO resistance
- ▶ Low power sleep mode (~10 μ A)
- ▶ Over temperature, over voltage and over current protection

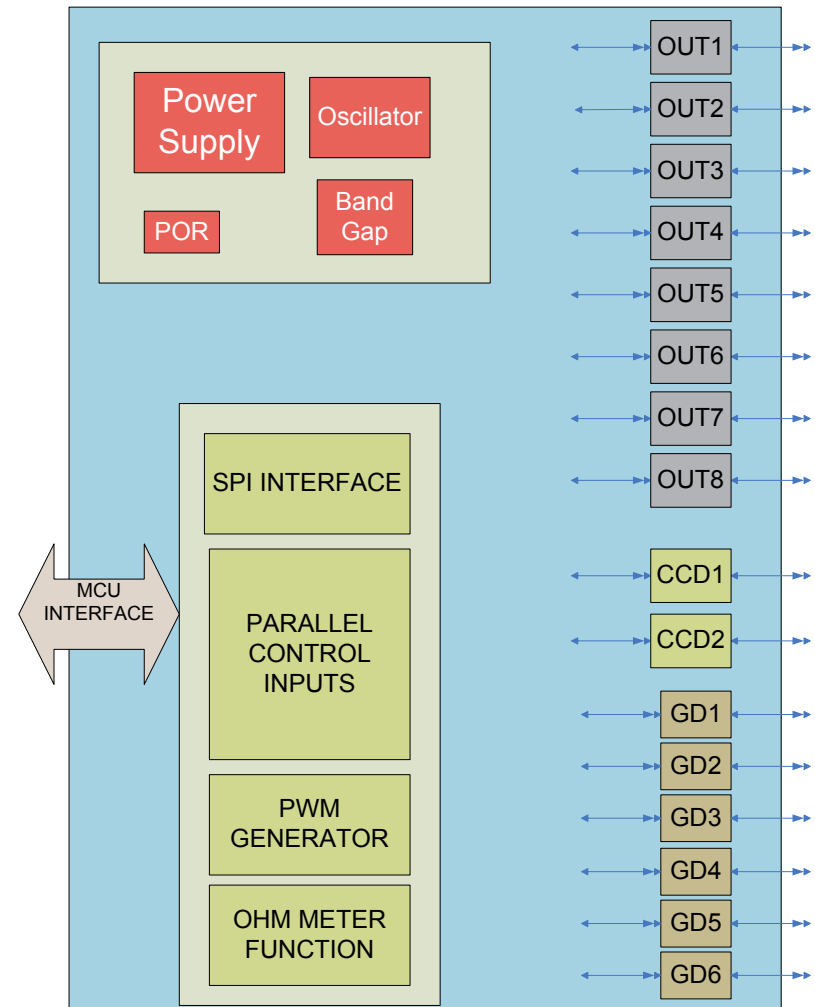

MC33800 Octal Serial Switch

1 of 8 similar low side switches

- ▶ Control via SPI or parallel
- ▶ Clamp circuit for inductive loads
- ▶ Open load detection
- ▶ Over current detection
- ▶ Over temperature detection
- ▶ Thermal and short protection
- ▶ OSS 1 & 2 have higher current capability
- ▶ Can be paralleled for increased current drive

To logic block of MC33800

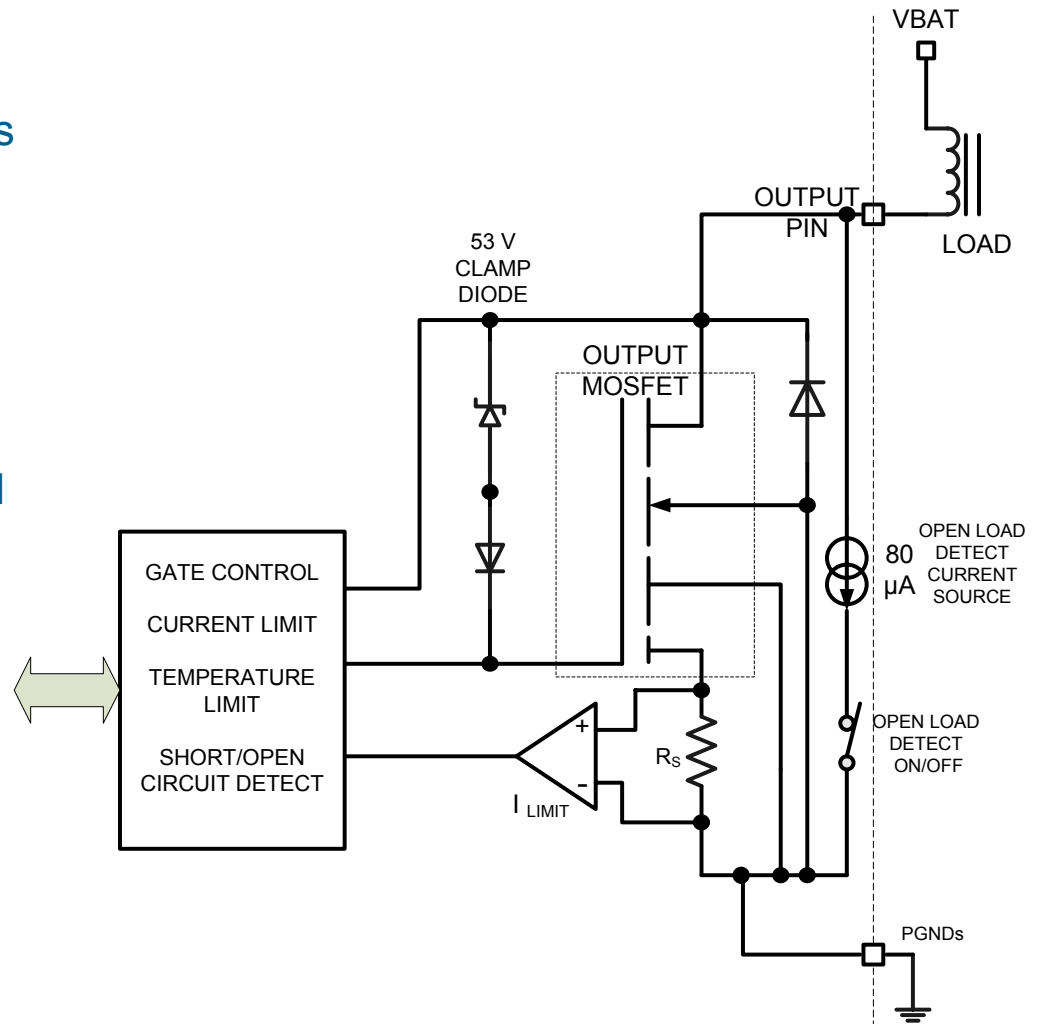

2 Constant Current Drivers

CCD1 and CCD2

- ▶ Both CCDs controlled via SPI
- ▶ Clamp circuit for inductive loads
- ▶ Open load detection
- ▶ Over current detection
- ▶ Over temperature detection
- ▶ Thermal and short protection
- ▶ CCD 1 0 to 1075 mA via SPI word
- ▶ CCD 2 0 to 232 mA via SPI word
- ▶ 9 bit D/A for setting current
- ▶ Built-in “dither” generator
- ▶ Dither frequency and amplitude are programmable via SPI
- ▶ CCD1 can also be used as a simple
 - ▶ 1 amp low side driver
 - ▶ Open load detect current source
 - ▶ can be enabled or disabled via SPI

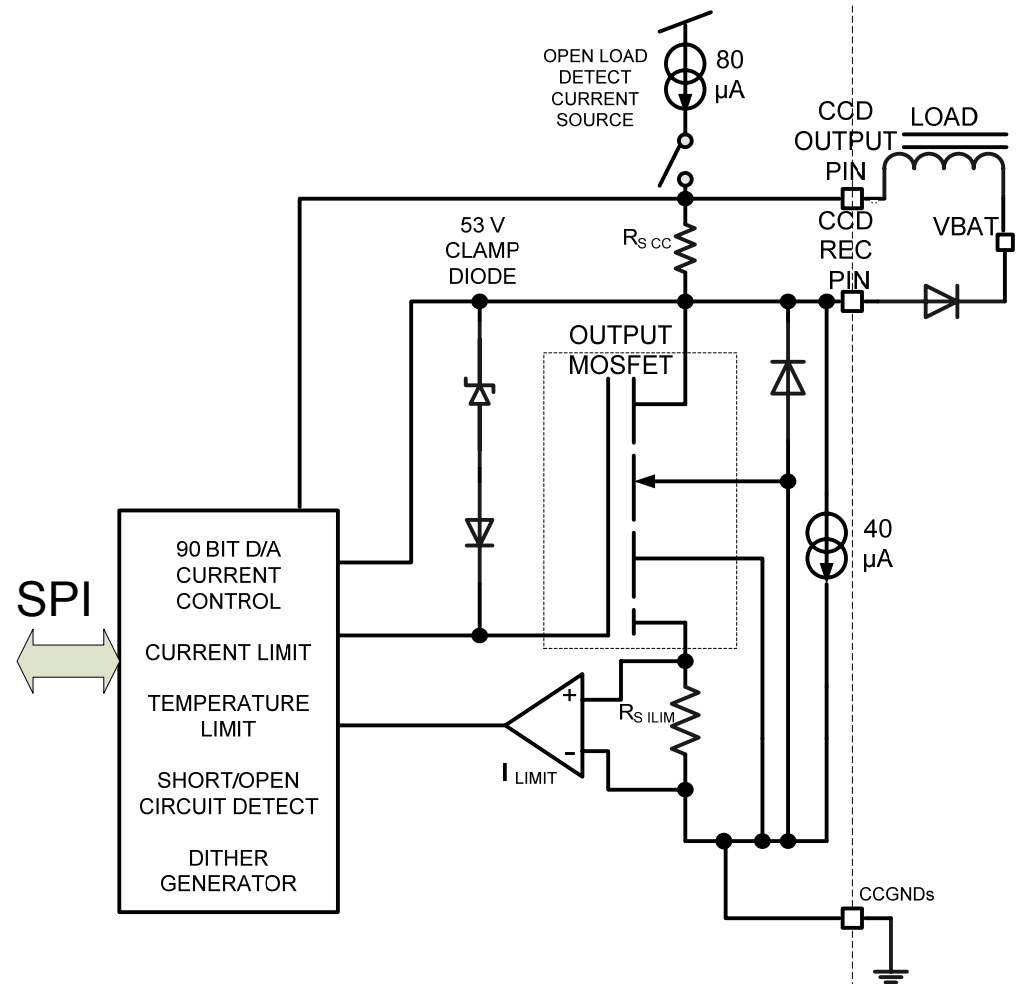

1 to 6 General Purpose Pre-Drivers

- ▶ Control by parallel, SPI, AND/OR of both
- ▶ Off state open load detect
- ▶ On state shorted load detect
- ▶ Programmable drain threshold and timer for short fault detection
- ▶ Load resistance ohmmeter function
- ▶ Built-in PWM function with programmable frequency and duty-cycle

Table 9. Frequency Select

Frequency Select Bits 987	Frequency Hz
000	10 Hz
001	20 Hz
010	40 Hz
011	80 Hz
100	160 Hz
101	320 Hz
110	640 Hz
111	1.28 kHz

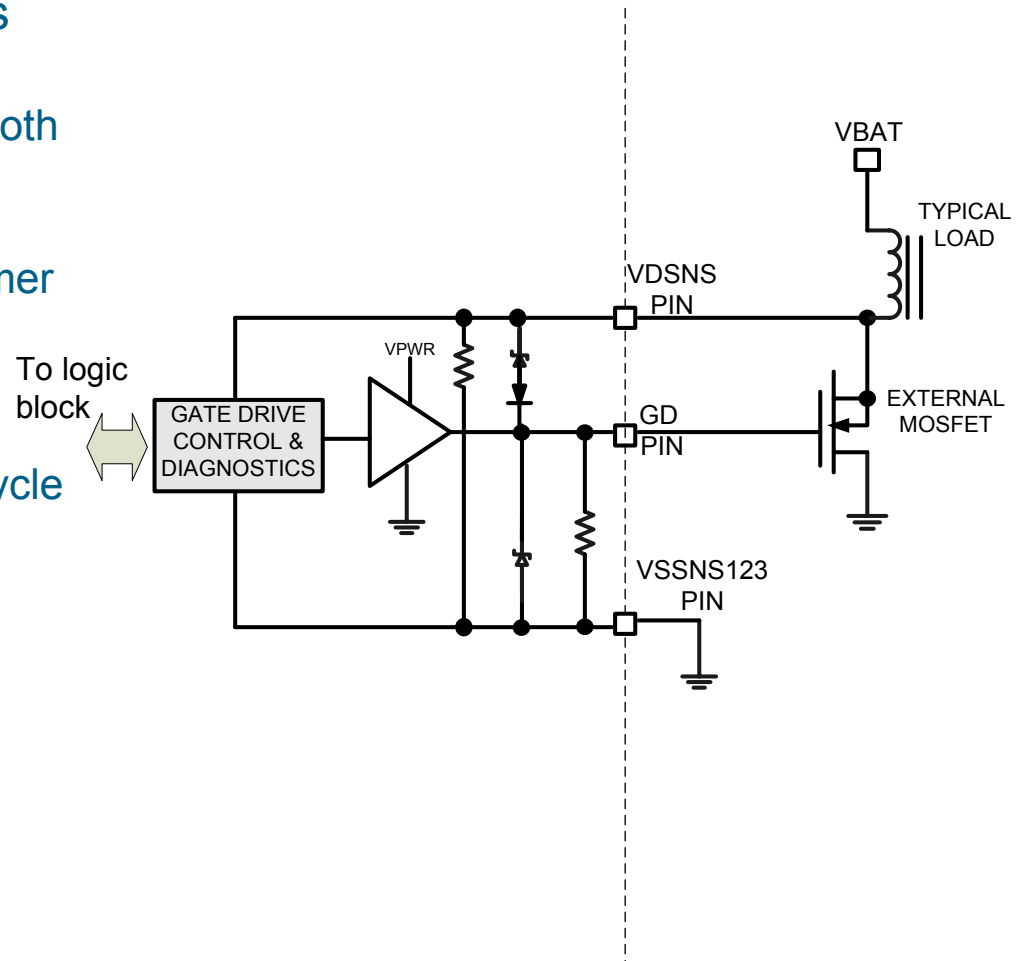

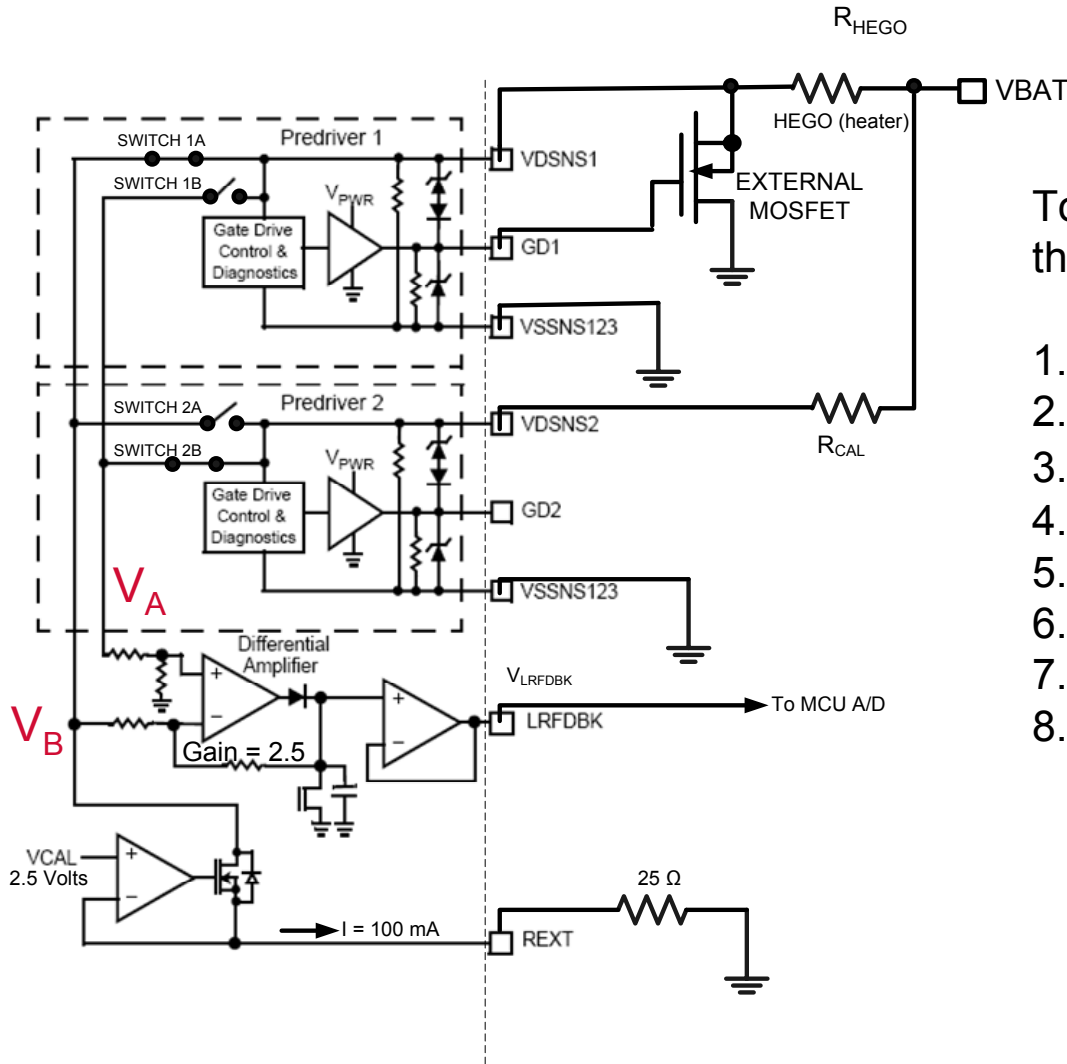

To read the resistance of the HEGO heater, R_{HEGO} :

1. Open switch 1B and 2A (via SPI)
2. Close switches 1A and 2B
3. 100 mA is drawn through R_{HEGO}
4. $V_B = V_{BAT} - (100 \text{ mA} \times R_{HEGO})$
5. $V_A = V_{BAT}$
6. $V_{LRFDBK} = 2.5 \times (V_{BAT} - V_B)$
7. $R_{HEGO} = V_{LRFDBK} / (100 \text{ mA} \times 2.5)$
8. $R_{HEGO} = V_{LRFDBK} / .25$

Additional accuracy can be obtained by reading R_{CAL} first and using the value read divided by the actual R_{CAL} value as a correction factor.

5 Ampere H-Bridge Family

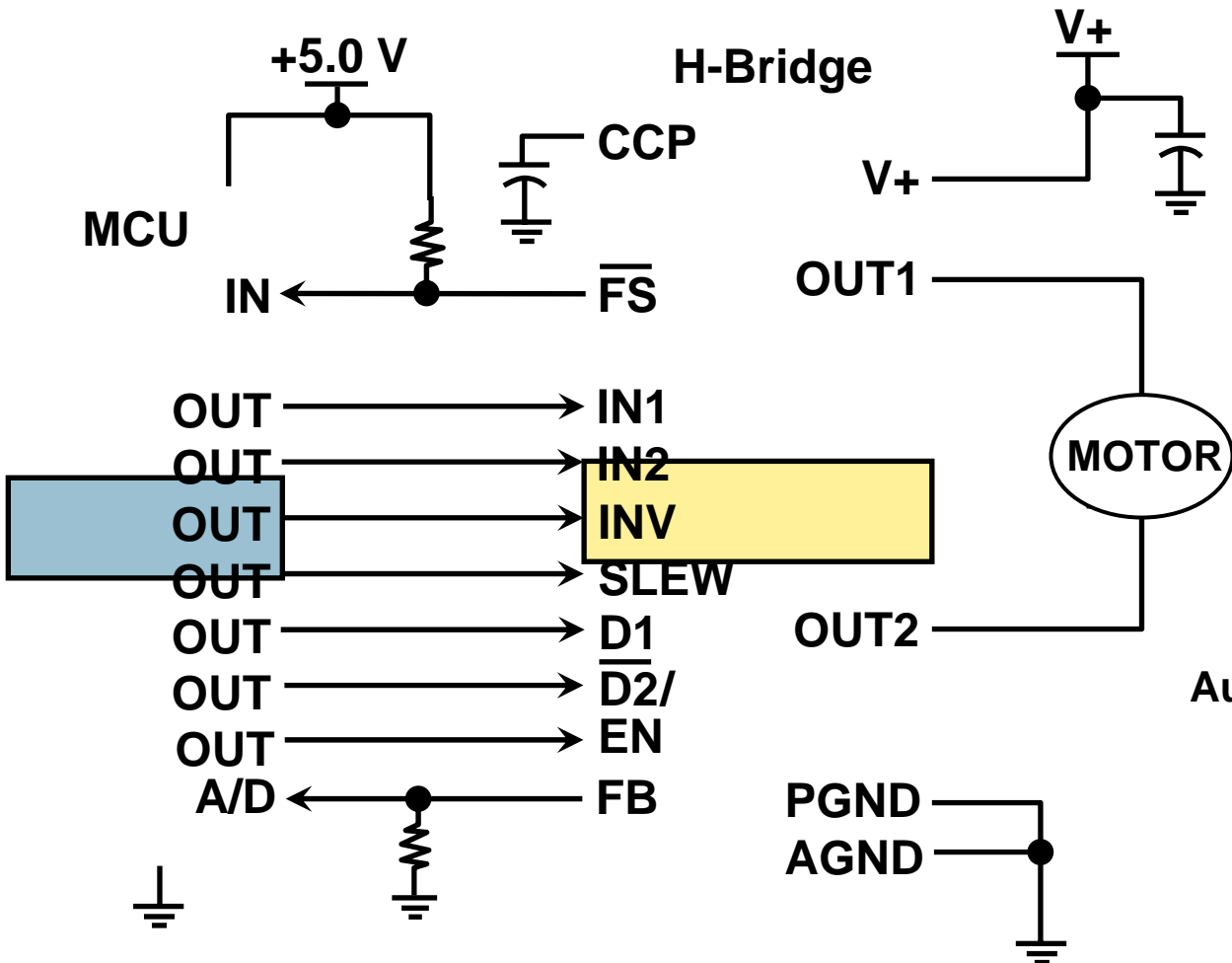

- MC33886
- MC33887
- MC33926
- MC33931
- MC33932 (2x MC33931)

Automotive Applications

- Throttle control
- Air bypass control
- EGR

► 5 amp throttle control H-bridge

- 8.0V to 28V continuous operation
- Transient operation from 5V to 36V
- 225 mΩ maximum RDS(ON) @ 150°C (each H-bridge MOSFET)
- 3.0V and 5.0V TTL/CMOS logic compatible Inputs
- Overcurrent limiting (regulation) via internal constant-off-time PWM
- Output short circuit protection (short to vpwr or ground)
- Temperature-dependent current-limit threshold reduction
- All inputs are Schmidt triggers with internal source/sink to define the
- Default (floating input) states
- Sleep mode with current draw < 50 μa (with inputs floating or set to match default logic states)

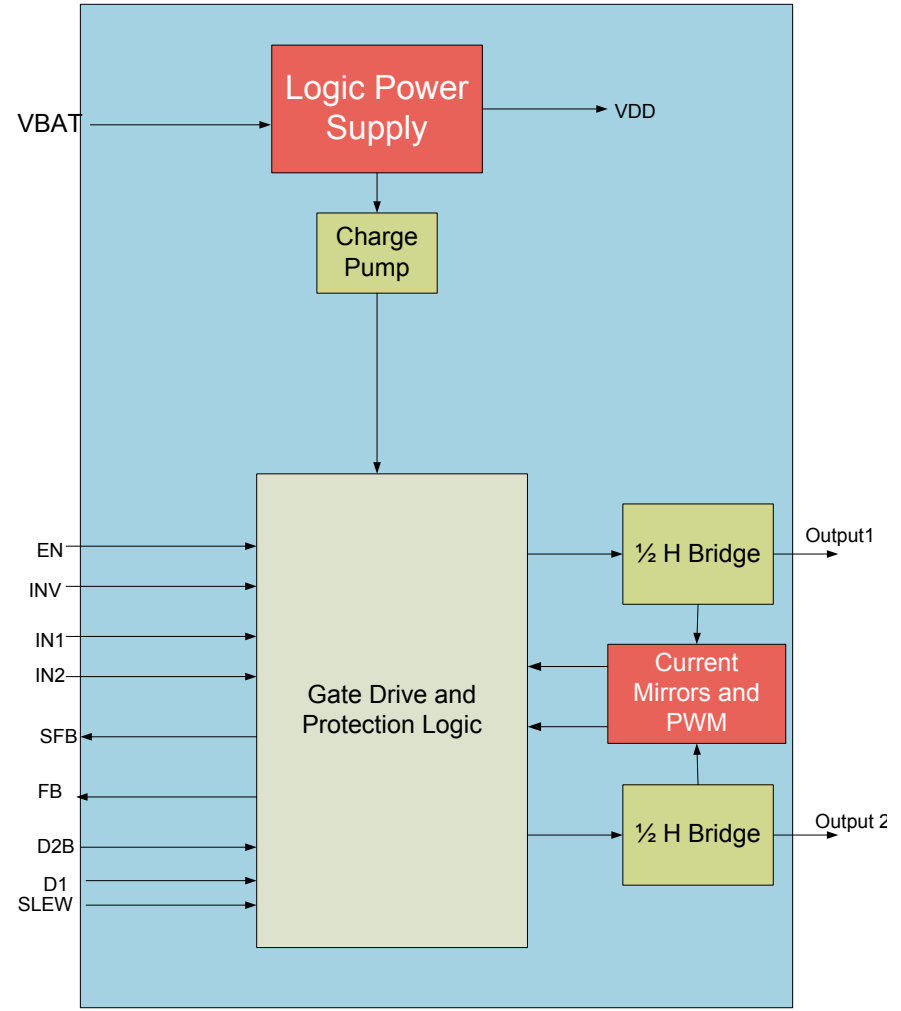

MC33879 Configurable Low/High Side Driver

- ▶ Eight floating MOSFETS
- ▶ Configure as high side or low side
- ▶ Combine to increase current
- ▶ Pair up for bridge driver
- ▶ Protection
- ▶ Diagnostics

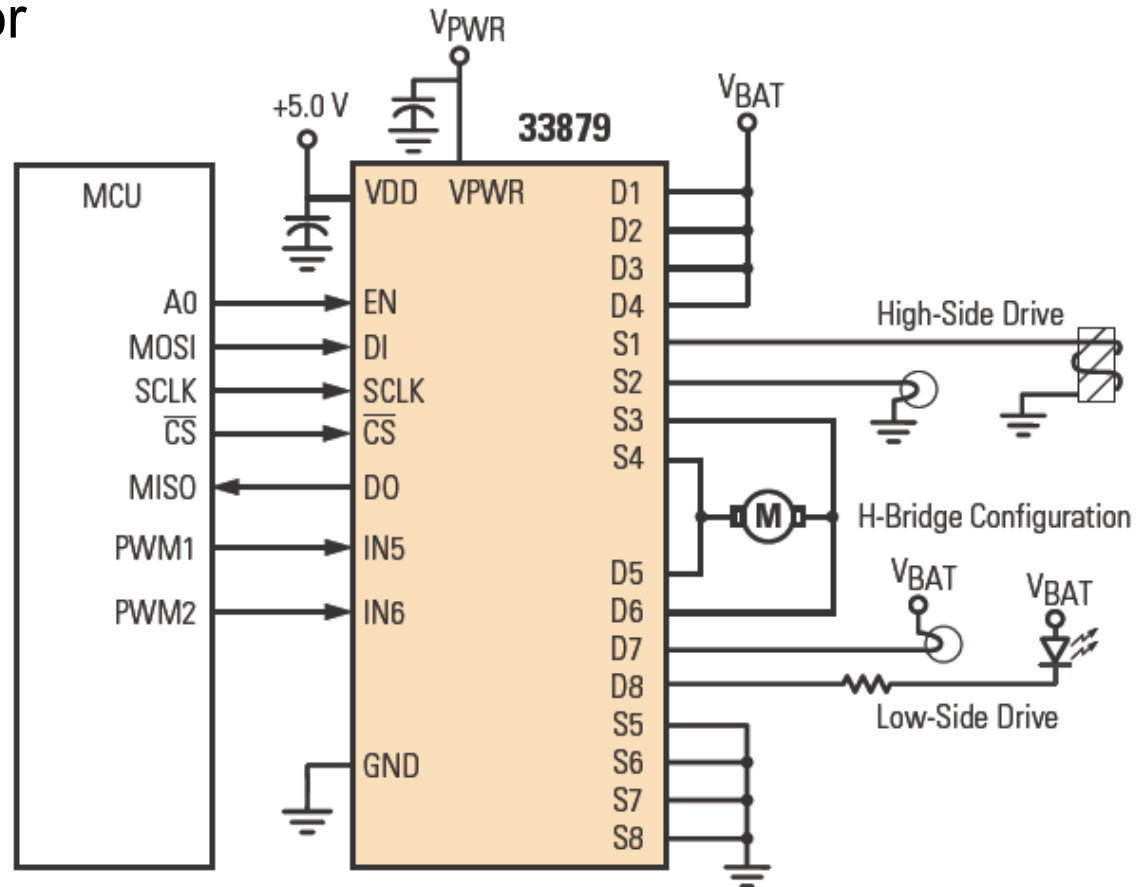

MC33879 as a 24V Switch Detector and Override

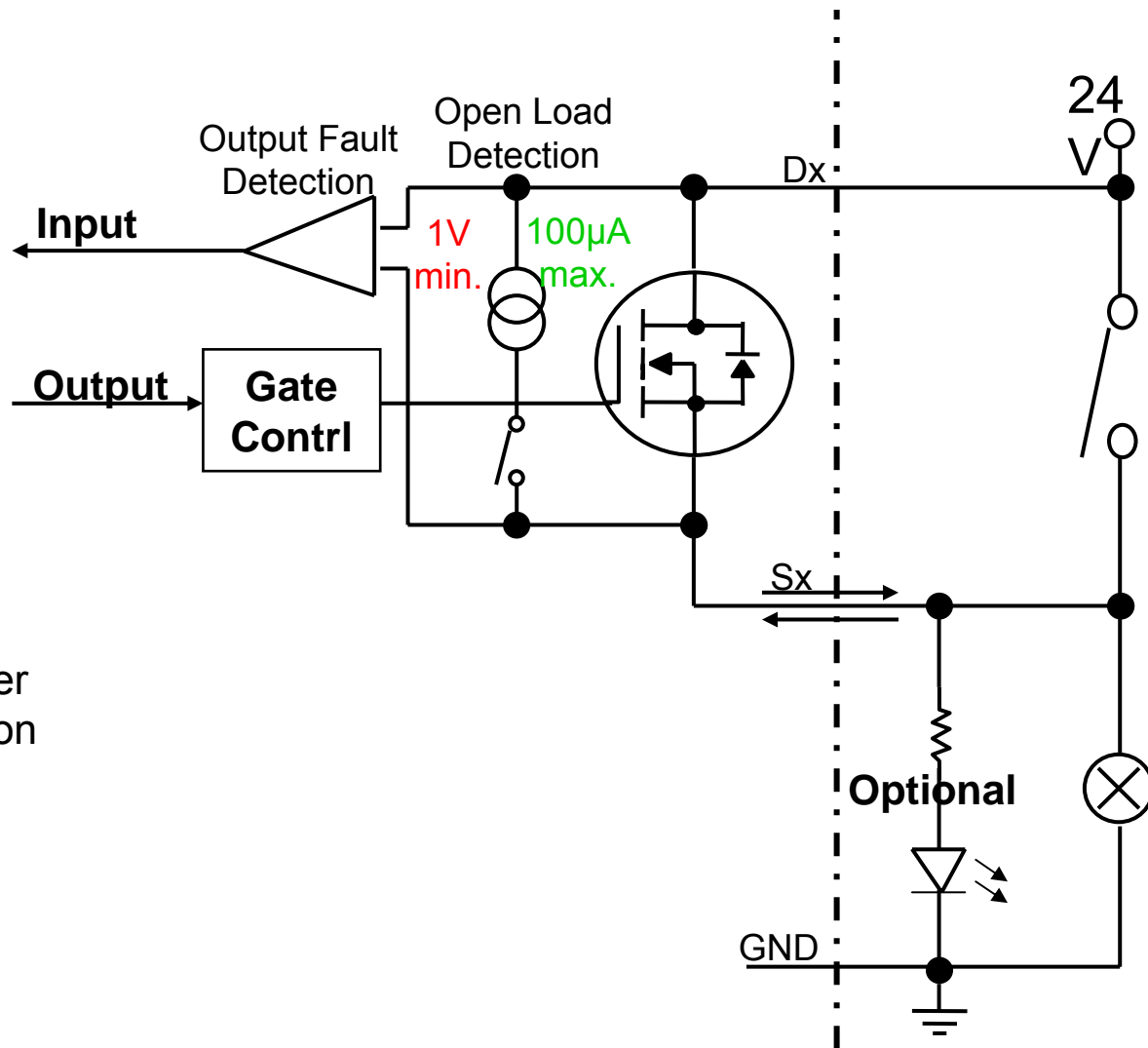

Example:

SPI driven I/O expander
in high-side configuration

MC33902 High Speed CAN with Diagnostics: Block Diagram

- ▶ High-speed CAN interface for baud rates of 40 kb/s to 1 Mb/s
- ▶ Embedded 5V supply
- ▶ Compatible to ISO11898 standard
- ▶ Single supply from battery; no need for 5 supply
- ▶ I/O compatible from 2.75V to 5V via a dedicated input pin
- ▶ Low power mode with remote CAN wake up and local wake-up recognition and reporting
- ▶ CAN bus failure diagnostic and TXD/RXD pin monitoring, cold start detection, wake up sources reported through the NERR pin
- ▶ Enhanced diagnostic for bus, TXD, RXD and supply pins available through a pseudo SPI using EN, NSTB and NERR existing pins
- ▶ Split pin for bus recessive level stabilization
- ▶ INH output to control external power supply

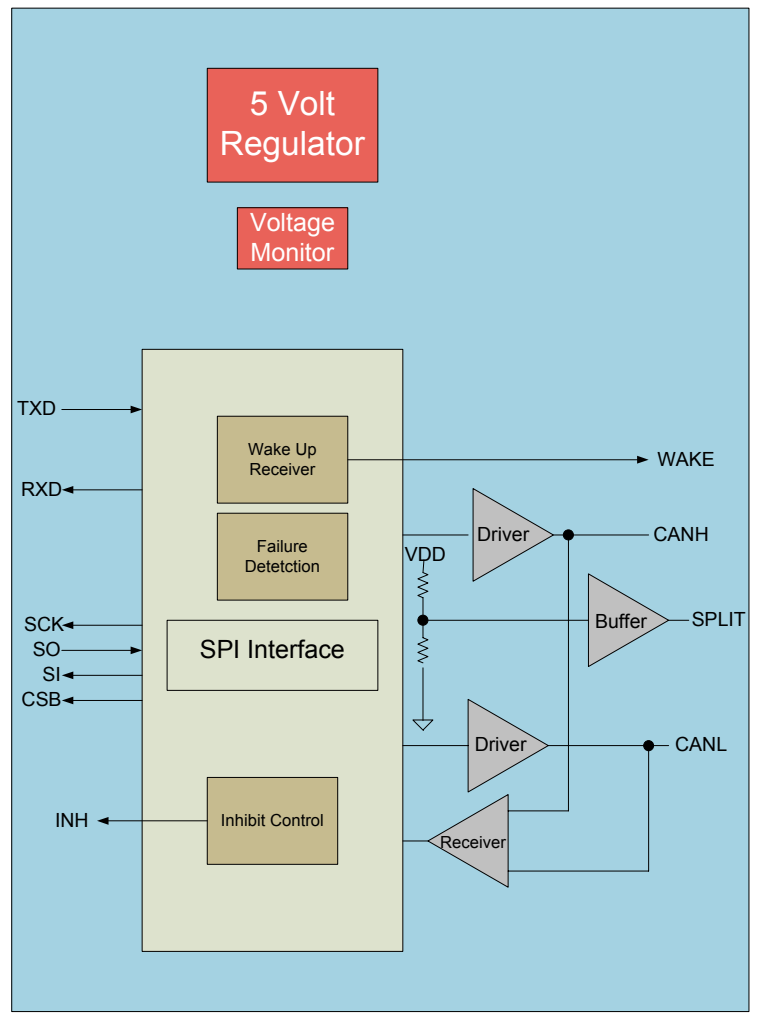

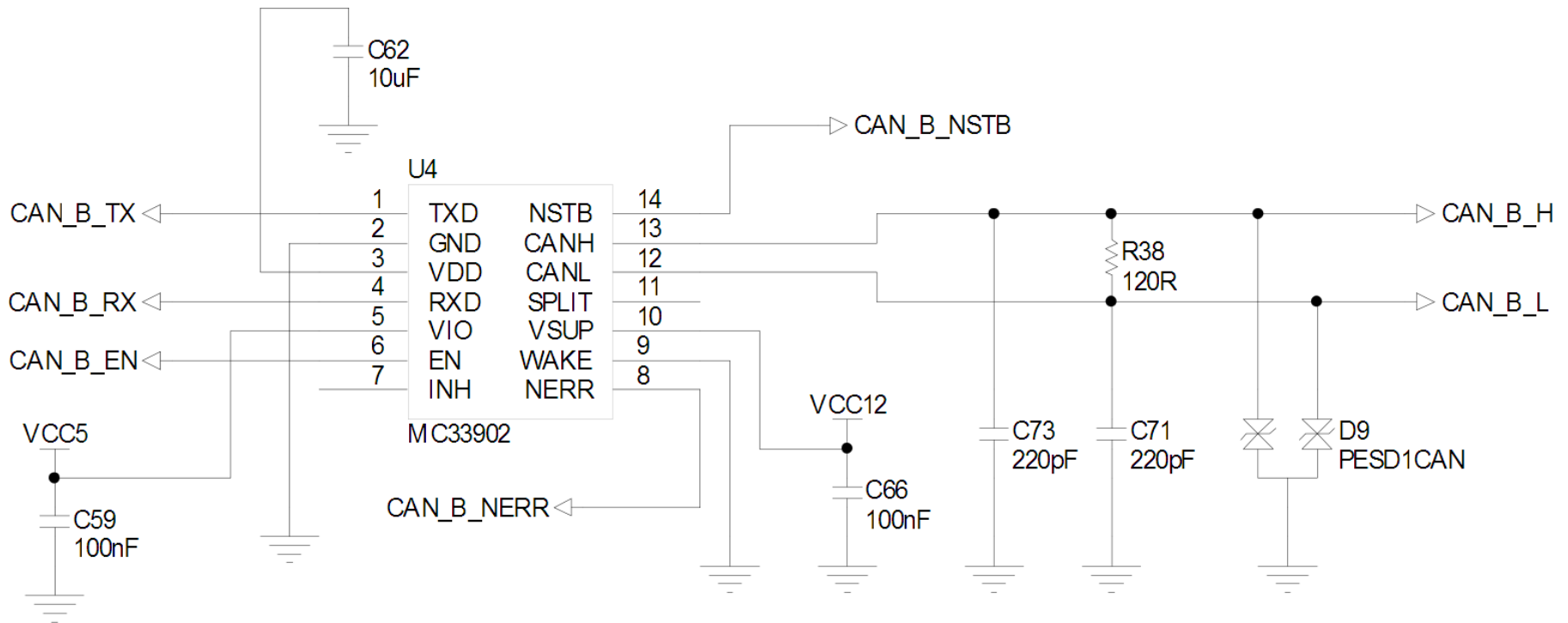

- ▶ Non-isolated, terminated CAN bus
- ▶ NERR, NSTB, EN can be used as a quasi-SPI interface to the MCU for error diagnostics.



Agenda

- ▶ Session objectives
- ▶ System block diagram and overview
- ▶ MPC563xM powertrain advantages and overview
- ▶ Secondary safety MCU
- ▶ SmartMOS devices
- ▶ **Pressure sensor**
- ▶ Software drivers and libraries
- ▶ Mechanics
- ▶ Summary



MPXH9005 Barometric Pressure sensor

Key Characteristics

- Ratiometric analog output
- Piezoresistive Transducer (PRT)
- Compensated digital IC provides calibrated output over temperature
- Output diagnostics and clipping
- Drop-In replacement (pin compatible) to MPX6115A

Features

- 1.5% accuracy
- 1ms response time
- Pressure range = 15 – 115 kPa
- 5V operating voltage
- FSL-programmable clipping level from 0 – 0.5V and 4.5 – 5V

Package

- SSOP-type pkg standard

Used to sense air pressure for air to fuel ratio calculations

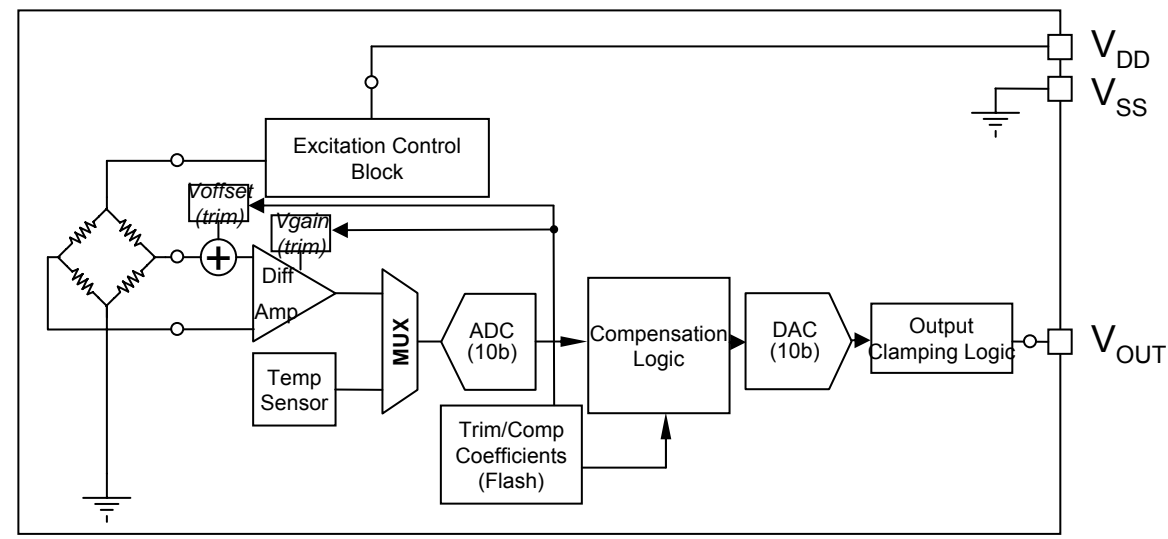
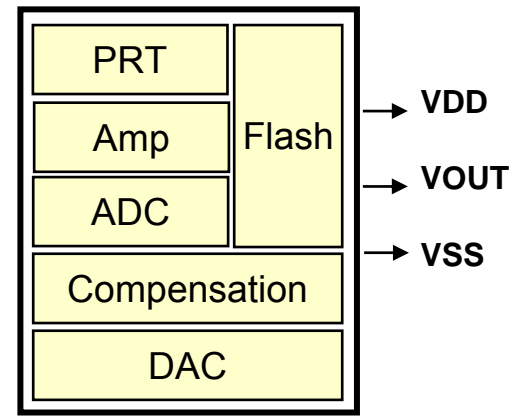



Agenda

- ▶ Session objectives
- ▶ System block diagram and overview
- ▶ MPC563xM powertrain advantages and overview
- ▶ Secondary safety MCU
- ▶ SmartMOS devices
- ▶ Pressure sensor
- ▶ **Software drivers and libraries**
- ▶ Mechanics
- ▶ Summary



FFT, IIR & FIR Digital Filters, 16-bit CRC, Sobel Filters

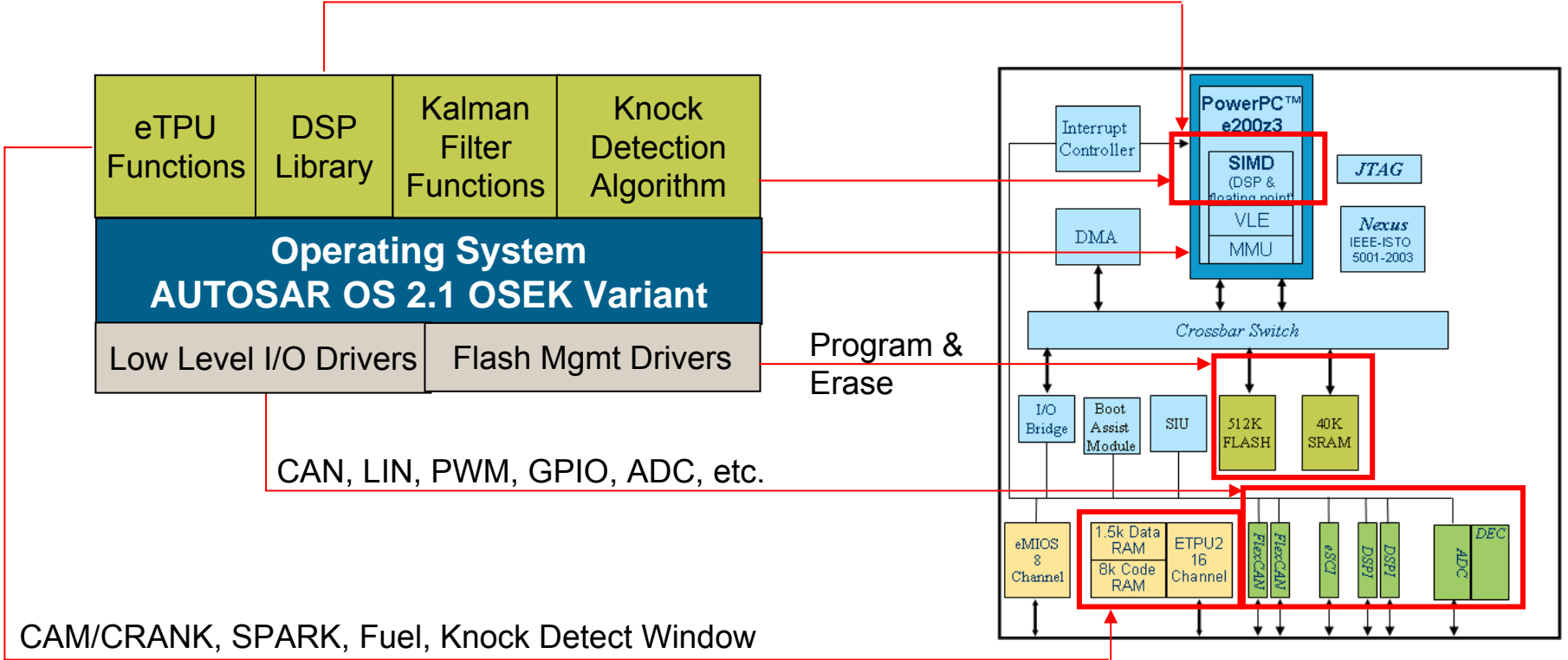

► For More Information Visit: <http://www.freescale.com/webapp/sps/site/overview.jsp?nodeId=02Wcbf148A>

Software to be Provided with Reference Design

- ▶ OSEK (license applies)
- ▶ eTPU function set 2
 - Crank
 - Cam
 - Fuel
 - Ignition
 - Knock window
 - Tooth generator to simulate crank and cam signals
- ▶ MC33905 driver
 - Set up of voltage regulator
 - LIN and CAN transceiver
 - Simple watchdog operation
- ▶ MC33810 driver
 - Injectors
 - Ignition
- ▶ MC33800 driver
 - Low side outputs – relays, lamps, gauges
 - HEGO heater
- ▶ MC33932 driver
 - Electronic throttle stepper motor
- ▶ Knock function
 - Setup of eQADC, eDMA, PIT, eMIOS together with eTPU set 2
- ▶ Freemaster CAN/serial driver
- ▶ XCP on CAN driver
 - Vektor or ETAS
- ▶ MC9S08 safety micro software

- ▶ Designated 'set2'
- ▶ AN3768SW
- ▶ Binary TPU code plus source API

Table 1. eTPU Functions

Function	Description	Related Application Note
CAM & CRANK	Engine position functions	AN3769
KNOCK_WINDOW	Knock window function	AN3772
FUEL	Fuel function	AN3770
SPARK	Spark function	AN3771
TOOTHGEN	Tooth generator function	AN3801

- ▶ Application notes available that include:
 - ▶ Binary eTPU code plus source API
- ▶ Download as AN3768SW from the Freescale website

- ▶ CamDecode - Engine position synchronization based on the cam signal (AN3769)
- ▶ FuelControl - Control the fuel pulse delivery. (AN3770)
- ▶ SparkControl - Control the spark firing angle and dwell time (AN3771)
- ▶ Knock Window – Generates windows for capturing the knock signal (AN3772)
- ▶ TOOTHGEN – Generate a simulated toothed wheel without real hardware (AN3801)

Online Tool for Compiling Libraries of Selected Functions

Select device

Select desired functions

Tool compiles the functions in real time

ZIP file provided for download



Agenda

- ▶ Session objectives
- ▶ System block diagram and overview
- ▶ MPC563xM powertrain advantages and overview
- ▶ Secondary safety MCU
- ▶ SmartMOS devices
- ▶ Pressure sensor
- ▶ Software drivers and libraries
- ▶ **Mechanics**
- ▶ Summary



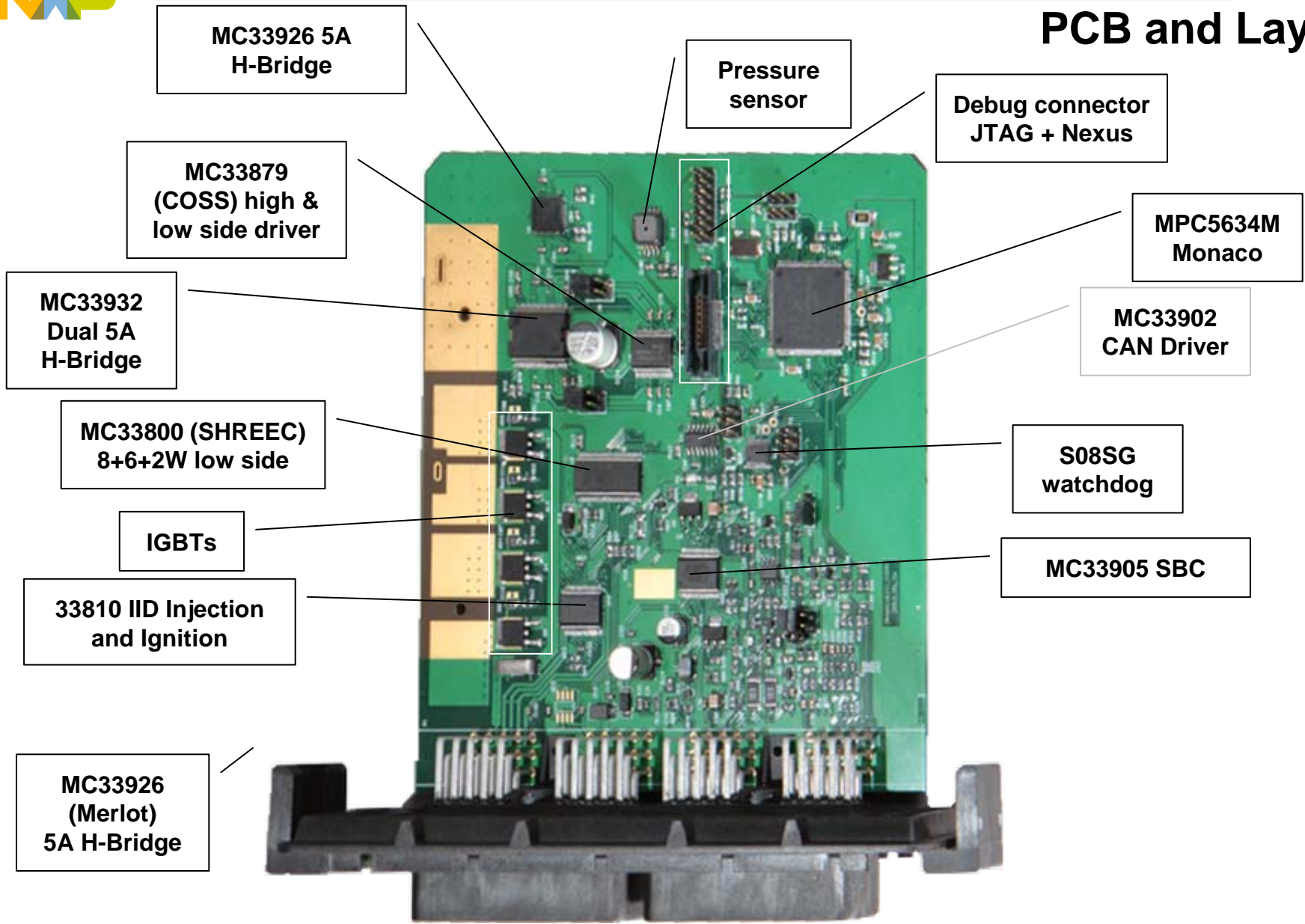

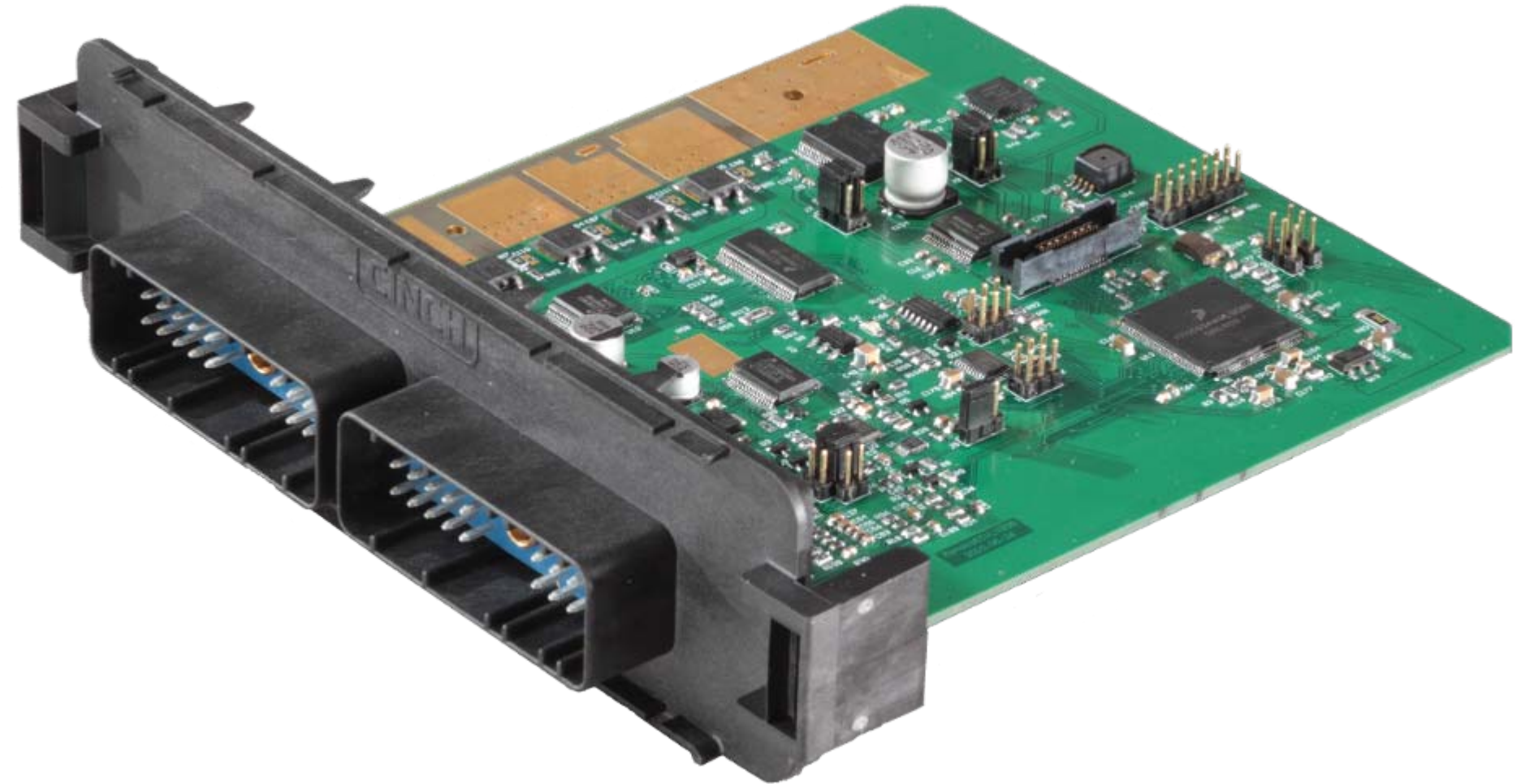

► Cinch enclosure

- 60 pin connector
- 2x keyed 30 pin headers



Environmental

Operating Temperature: -40°C to + 85°C

Sealing: IP65, IP66, IP67, IP69

Vibration/Shock: 0-2000-10 Hz, 15 g's for 24 hrs – 8 hrs each perpendicular axis

Current Cycling: 500 hrs at rated current (45 min on – 15 min off)

Temperature Life: 1008 hrs @ 125°C

Temperature / Humidity Cycling: 40 – 8 hrs cycles between -40°C to + 125°C, relative humidity 0 to 85%

Salt spray: 96 hrs @ 5% NaCl

High Pressure Wash: 200°F steam / detergent spray at 200 psig for 30 sec. - 100°F water / detergent spray at 750 psig for 30 sec

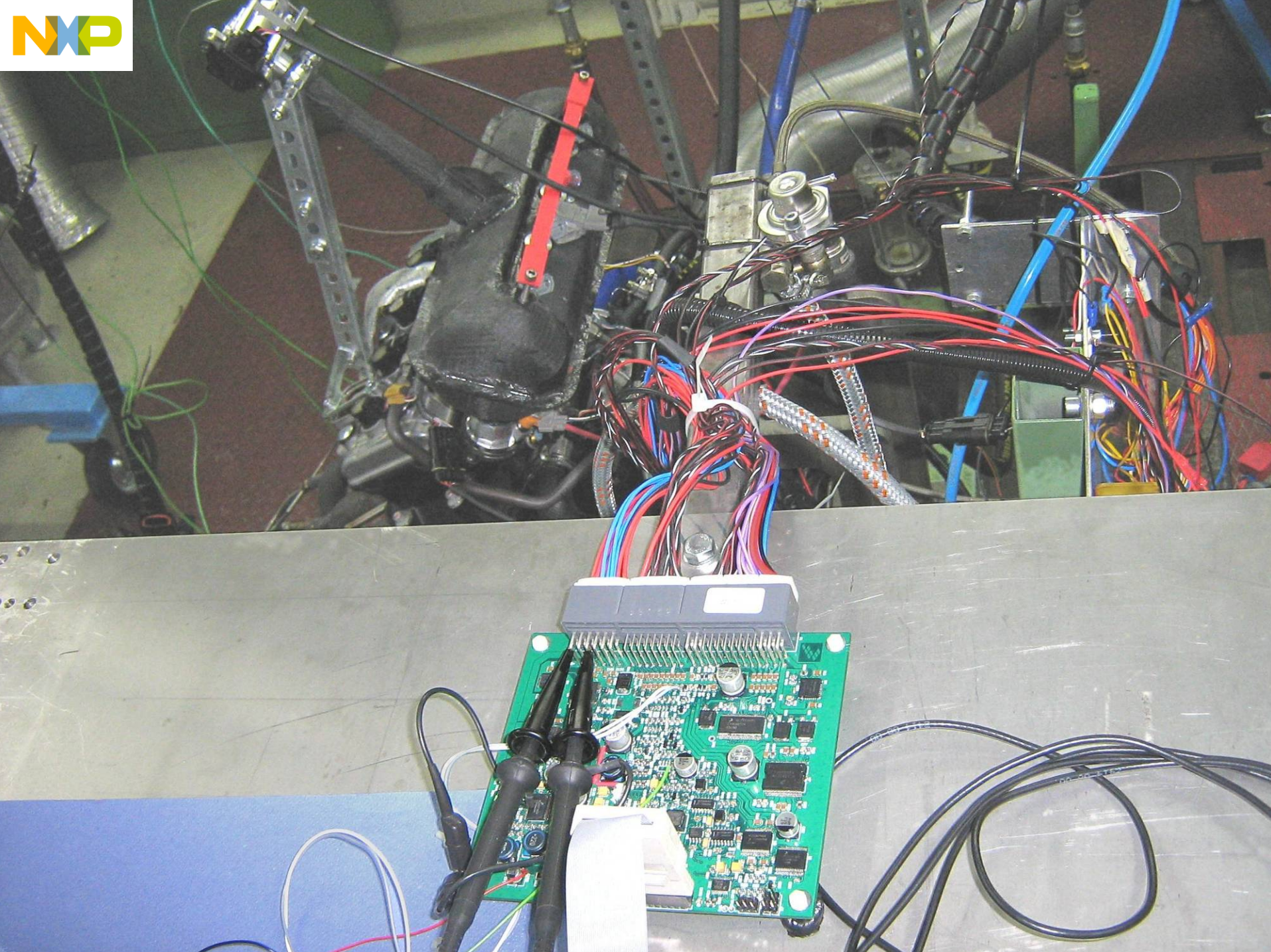



Agenda

- ▶ Session objectives
- ▶ System block diagram and overview
- ▶ MPC563xM powertrain advantages and overview
- ▶ Secondary safety MCU
- ▶ SmartMOS devices
- ▶ Pressure sensor
- ▶ Software drivers and libraries
- ▶ Mechanics
- ▶ **Summary**



- **150 MHz Power Architecture™ e200z4d Core + VLE**
 - Dual Issue Core with SPE Module for Floating Point & DSP
 - 8kB Instruction Cache - 2 or 4 way - with error detection
 - 24 Entry MMU, NMI, Power Saving mode

Memory

- **4MB Byte RWW Flash with ECC**
- **217kB Total SRAM**
 - 192kB on chip static RAM (including 32kB standby) with ECC
 - 8kB unified-cache (with line locking)
 - 17kB for eTPU (14kB code & 3kB data)

I/O

- **Timed I/O Channels**
 - 32 channel eTPU2
 - 24 channel eMIOS
- **FlexRay**
 - Dual Channel (10MB/s)
- **Reaction Module** – 6 channel support
- **3 x FlexCAN** - Compatible with TouCAN, 64 Message Buffers Each
- **3 x eSCI**
- **3 x DSPI** 16 bits wide up to 6 chip selects each
 - SPI with continuous mode and DMA support
 - Supporting Micro Second Bus, optionally using LVDS
- **1 x CRC unit**
- **40 channel Dual ADC** - up to 12 bit and up to 670ns conversions
 - 6 Queues with triggering and DMA support
 - Variable Gain Amplifier (X1, X2, X4)
 - Dual Decimation Filters
 - Temperature sensor and Absolute voltage reference

System

- **FM-PLL**
- **64 Channel enhanced DMA Controller**
- **Peripheral Interrupt Timer (PIT)** (capable of queue triggering)
- **System Timer Module (STiM)** (for AutoSAR task monitor function)
- **Software Watchdog (SWaT)** (windowing watchdog)
- **378 source Interrupt Controller (plus NMI)**
- **Nexus IEEE-ISTO 5001-2003 Class 3+ (ETPU Class 1)**
- **Single 5V Power supply is optional for 208 and 176 QFP packages only**
- EBI and calibration busses (16/32bit)
- 176 LQFP / 208MapBGA / 324PBGA (bus, 40ADC)

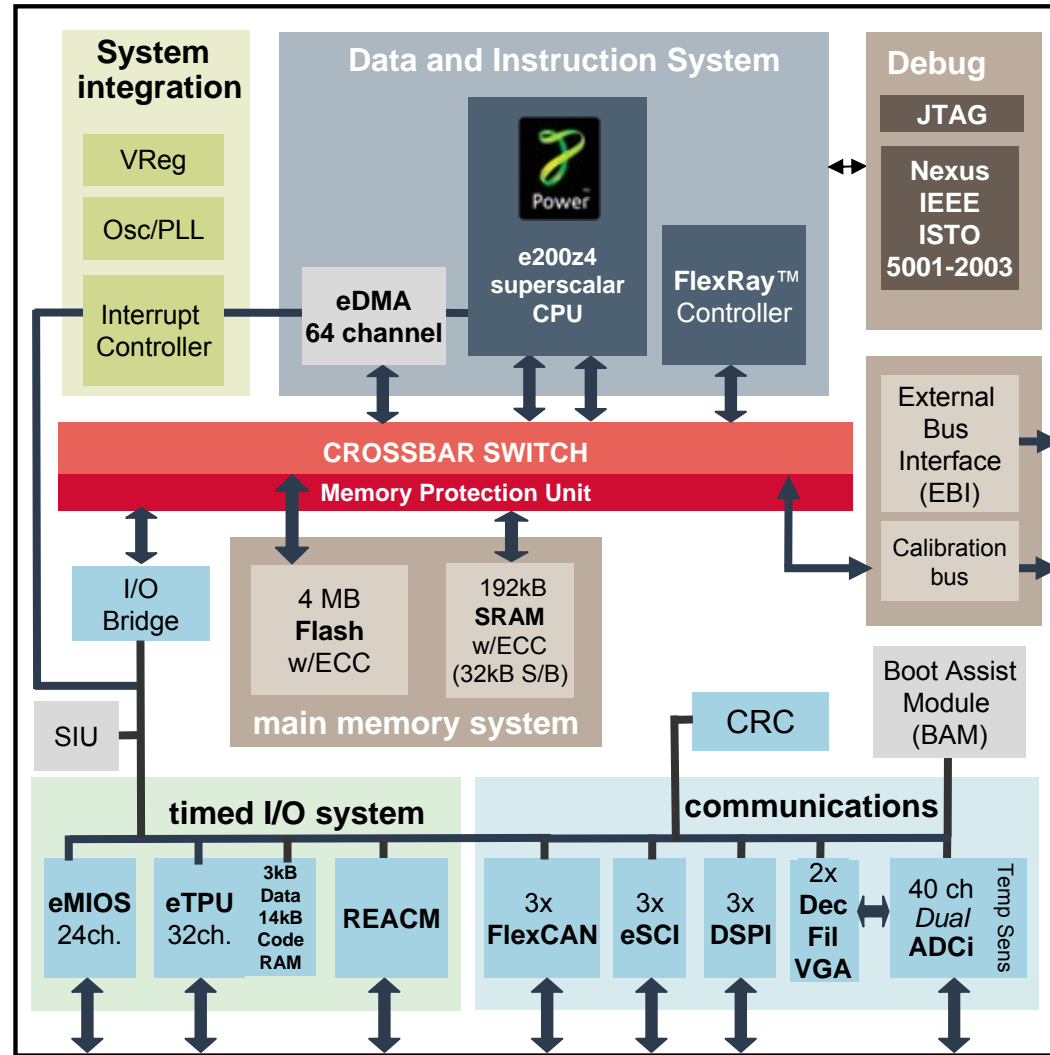

MPC5633M Rev2 ECU Block Diagram

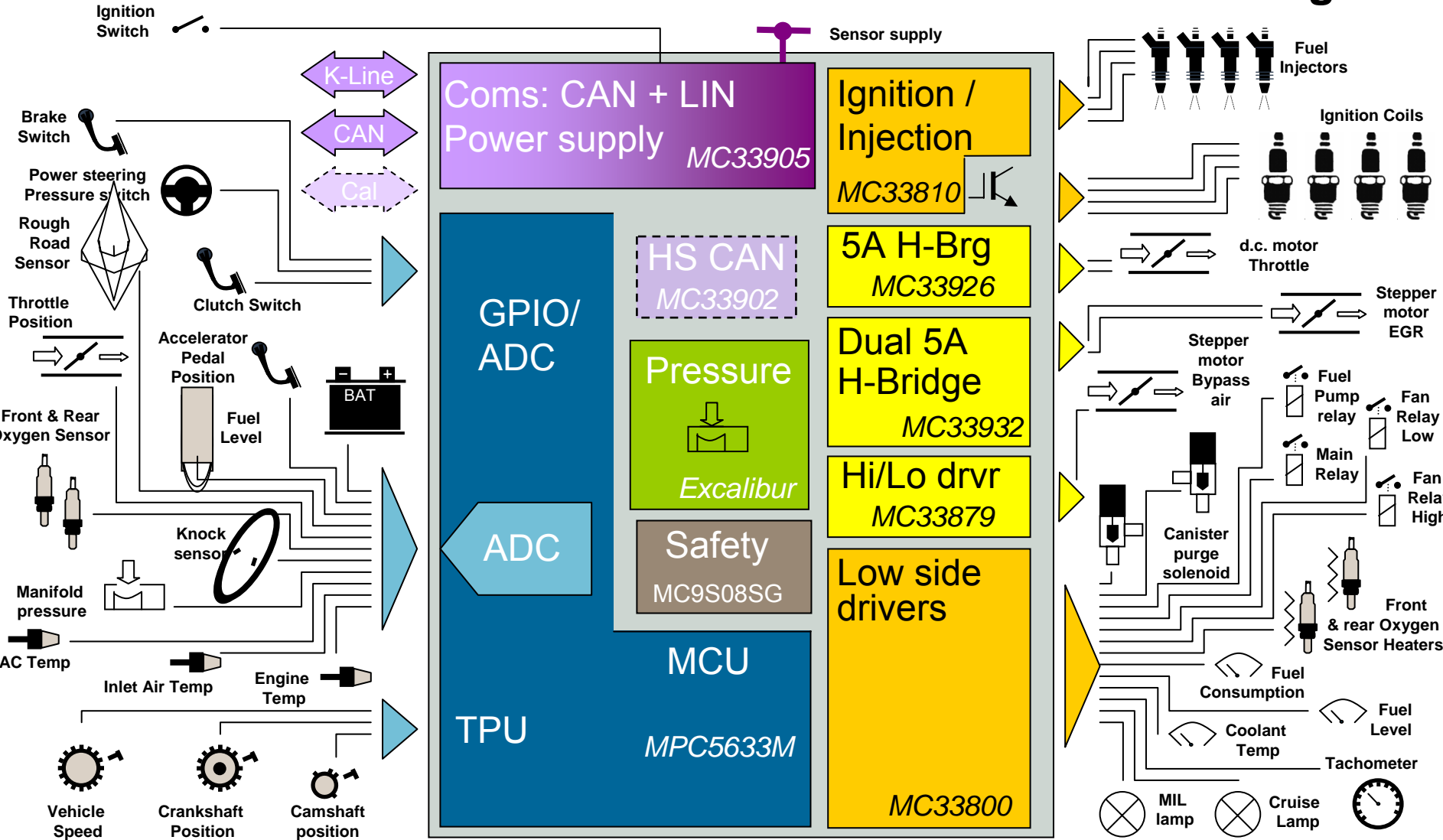

Session Code	Session Title	Class Level
FTF-AUT-F0341	Automotive MCU Architectures for the Future	Basic
FTF-AUT-F0553	Freescale Solutions for Powertrain and Hybrid	Basic
FTF-AUT-F0556	Analog Mixed Signal and Power Products for Automotive	Basic
FTF-AUT-F0732	SBCs: Power Management Solutions for 16- and 32-bit MCUs in Automotive Applications	Basic
FTF-AUT-F0819	Rapid Software Development on 32-bit Automotive MPC56xx Family of MCUs	Basic
FTF-AUT-F0354	Reducing System Cost with Integrated MCU Solutions for Engine and Transmission Applications	Intermediate
FTF-AUT-F0678	MPC5674F Optimizing Software for Performance	Intermediate
FTF-AUT-F0679	MPC563xM Low-End Engine Control Hardware Design	Intermediate
FTF-AUT-F0680	MPC567xF Powertrain System Hardware Design	Intermediate
FTF-AUT-F0684	Hands-on Workshop: An Overview of Freescale's Analog Standard Products for the Powertrain Market with Emphasis on the Newest and Most Versatile	Intermediate
FTF-AUT-F0730	Automotive Networking Protocol Overview	Intermediate
FTF-AUT-F0764	Hands-on Workshop: AUTOSAR	Intermediate
FTF-AUT-F0447	Using Enhanced Time Processing Unit (eTPU/eTPU2) for Combustion Engine Management and Electric Motor Control	Advanced
FTF-AUT-F0451	Tips and Tricks with DMA on MPC56xx	Advanced
FTF-AUT-F0737	MCU Solutions for Hybrid Drive Train	Advanced

Bolded sessions are highly recommended.



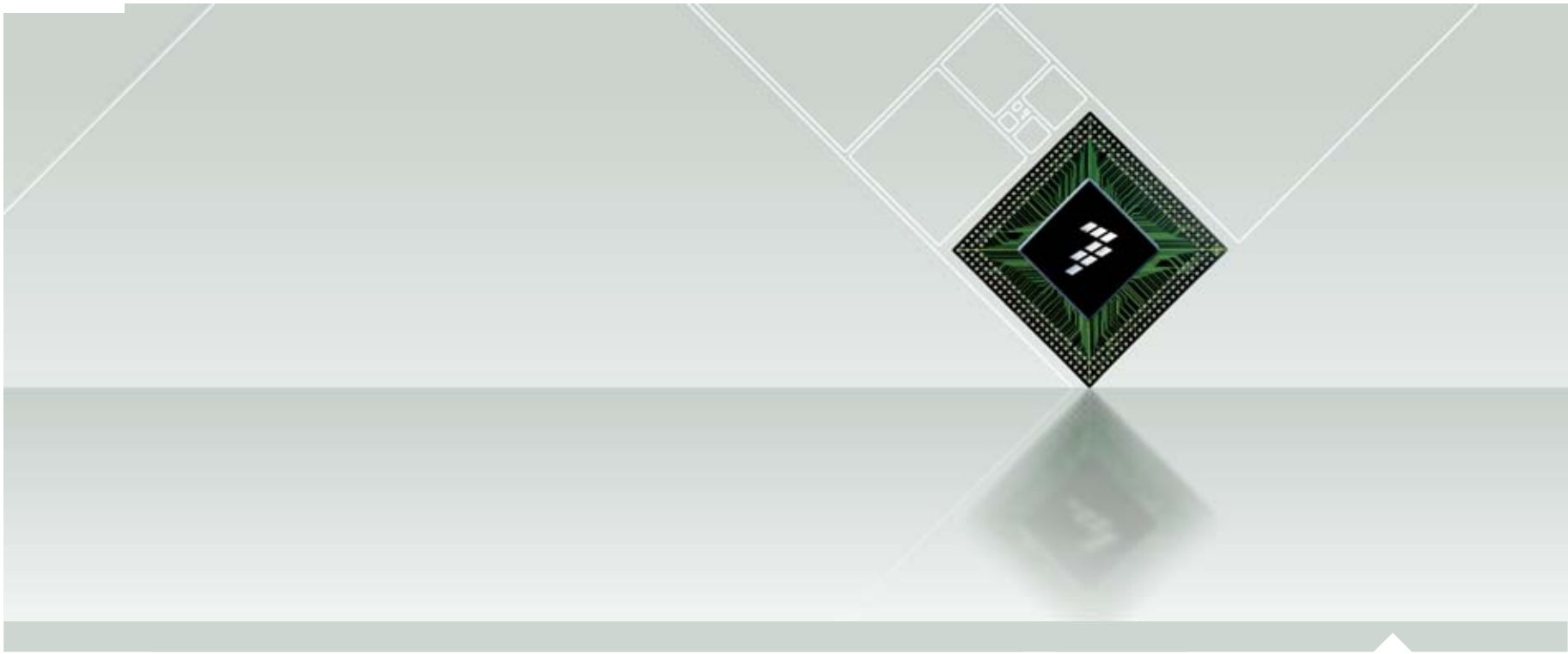

Back-up



Agenda

- ▶ Project objectives
- ▶ Block diagram
- ▶ Monaco powertrain advantages
- ▶ SmartMOS devices
- ▶ Pressure sensor
- ▶ Software drivers and libraries
- ▶ **Application model**



► Simulink model autocoded with Real Time Workshop (RTW)

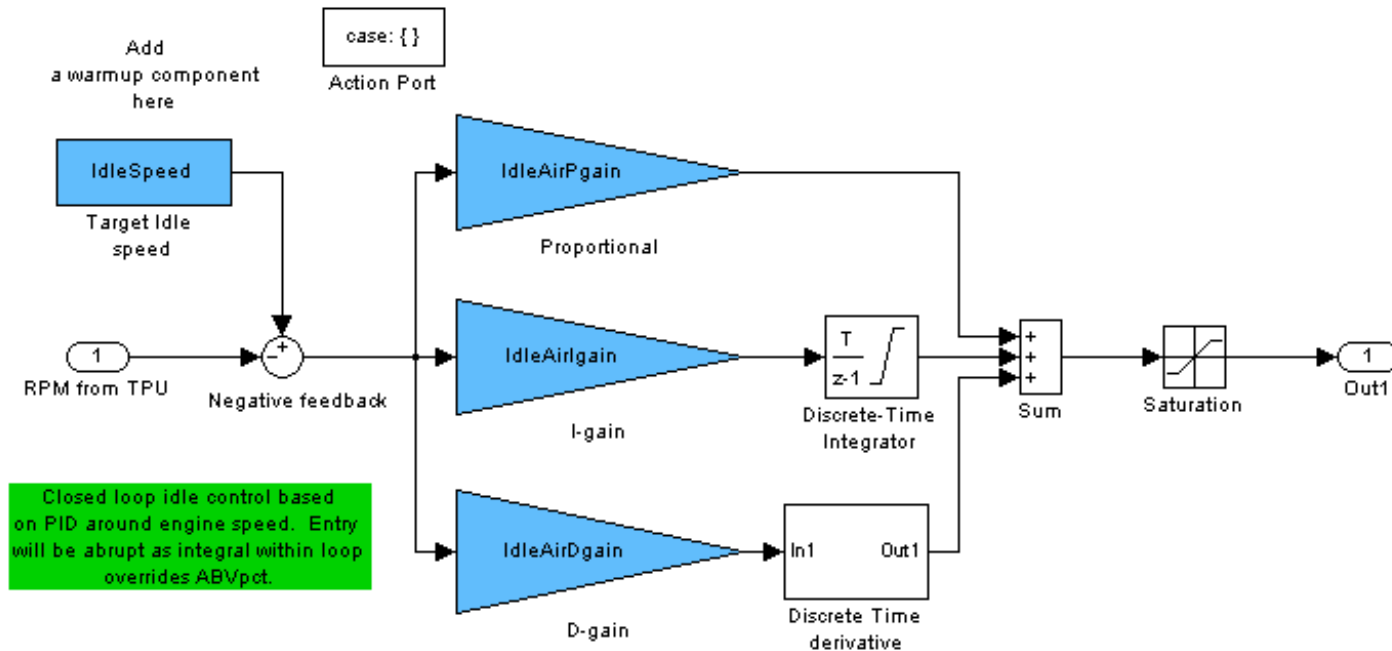

Model Browser

- Sensortest_6dec09
 - MonacoECUApplicationCode
 - Algorithms
 - Air bypass function
 - Fuel Function
 - Fuel Pump Function
 - Spark Function
 - AnalogInputs
 - Absolute Analog Inputs
 - Ratiometric Analog Input
 - Hardware Abstraction Layer
 - ABV % to driver interface
 - Modal Control
 - Engine Modal Control
 - Fuel Modal Control
 - Spark modal control
 - Throttle Modal Control

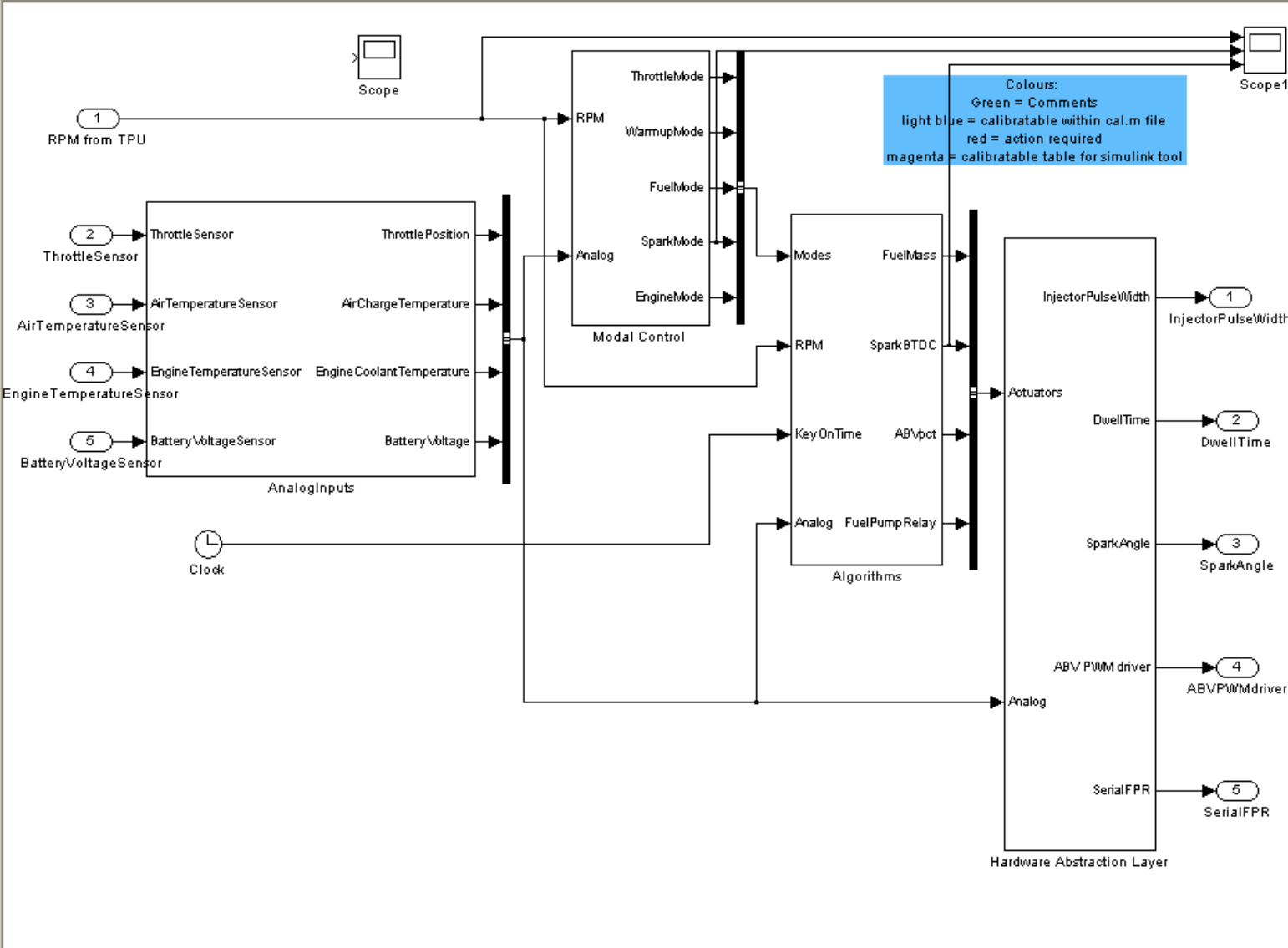

PCB and Layout (rev 1)

