

FS04_PB

High-voltage safety PMIC with SMPS and LDO

Rev. 1.0 — 11 June 2024

Product brief



Document information

Information	Content
Keywords	FS04, PMIC, central compute, ASIL D, gateway, in-vehicle network, domain controller, telematics
Abstract	The FS04 is an automotive multi-output power management IC that focuses on central compute, gateway, in-vehicle network, and domain controller applications. The device includes a high-voltage buck converter, multiple high-efficiency switch modes and linear voltage regulators.



1 Overview

The FS04 is an automotive multi-output power management IC that focuses on central vehicle controller, gateway, in-vehicle network, and domain controller applications. The device includes a high-voltage buck converter, multiple high-efficiency switch modes and linear voltage regulators.

The FS04 includes enhanced safety features with fail-safe outputs and dedicated safety pins for the processor S32N. The device covers ASIL B and ASIL D safety integrity levels. It complies with the ISO 26262 standard and is qualified in accordance with AEC-Q100 rev H (Grade1, MSL3). The FS04 can be fully utilized in safety-oriented system partitioning and can also be configured to operate as a non-safety QM-version part.

The FS04 is available in several versions that support a variety of safety applications and offer numerous choices with respect to the number of output rails, output voltage settings, operating frequencies, and power-up sequencing.

2 Features

- A high-voltage synchronous buck controller, driving external MOSFETs:
 - Input voltage, 3 V to 60 V
 - Output voltage from 3.3 V to 5.3 V
 - Up to 1.5% DC accuracy in pulse width monitoring (PWM) mode and 3% DC accuracy in pulse frequency monitoring (PFM) mode
 - 50 mA gate drive capability, up to 20 A DC output current capability
 - Switching frequencies 312 kHz to 455 kHz
- Five buck regulators with internal power stage
 - BUCK1 single-phase operation, 1 V to 1.8 V @ 2.5 A DC with up to 1.0 % DC accuracy
 - BUCK2 single-phase operation, 1 V to 1.8 V @ 2.5 A DC with up to 1.0 % DC accuracy
 - BUCK3 single-phase operation, 0.4 V to 1.8 V @ 2.5 A DC with up to 1.0 % DC accuracy
 - BUCK4 single-phase operation, 0.4 V to 1.8 V @ 2.5 A DC with up to 1.0 % DC accuracy
 - BUCK5 / switch mode, 0.6 V to 1.8 V @ 70 mA in buck mode and 150 mA in switch mode
- One low-power linear regulator
 - LDO1: LDO/load Switch with output voltage from 1.1 V to 3.3 V @ 400 mA DC
- One boost regulator with integrated low-side switch
 - Output voltage, 4.5 V to 5.5 V @ 1 A DC with up to 2.0 % DC accuracy
- Advanced frequency management, including frequency spread spectrum, slew rate control, manual frequency tuning.
- Functional safety architecture to target ASIL D applications.
- ABIST and LBIST for latent fault detection
- Optimized low-power architecture
- High-speed I²C interface with up to 3.4 MHz operation
- Advanced thermal monitoring and thermal shutdown protection
- 64-pin QFN package with exposed pad and 0.5 mm pitch
- Automotive qualified AEC-Q100 up to Grade 1

3 Applications

- Central vehicle controller
- Gateway
- In-vehicle networks
- Domain controllers

4 Ordering information

Table 1. Ordering information

Type number	Package		
	Name	Description	Version
FS0400	QFN64	QFN64 package with exposed pad, thermally enhanced wettable flanks, 64 terminals, 0.5mm pitch, 9 mm x 9 mm.	SOT804-8(DD)

Table 2. Ordering part number and OTP version

Part number	NXP processor	Safety grade	OTP ID
PFS0400AMDA3ES	S32N	ASIL D	DA3

5 Device description

5.1 Functional block diagram

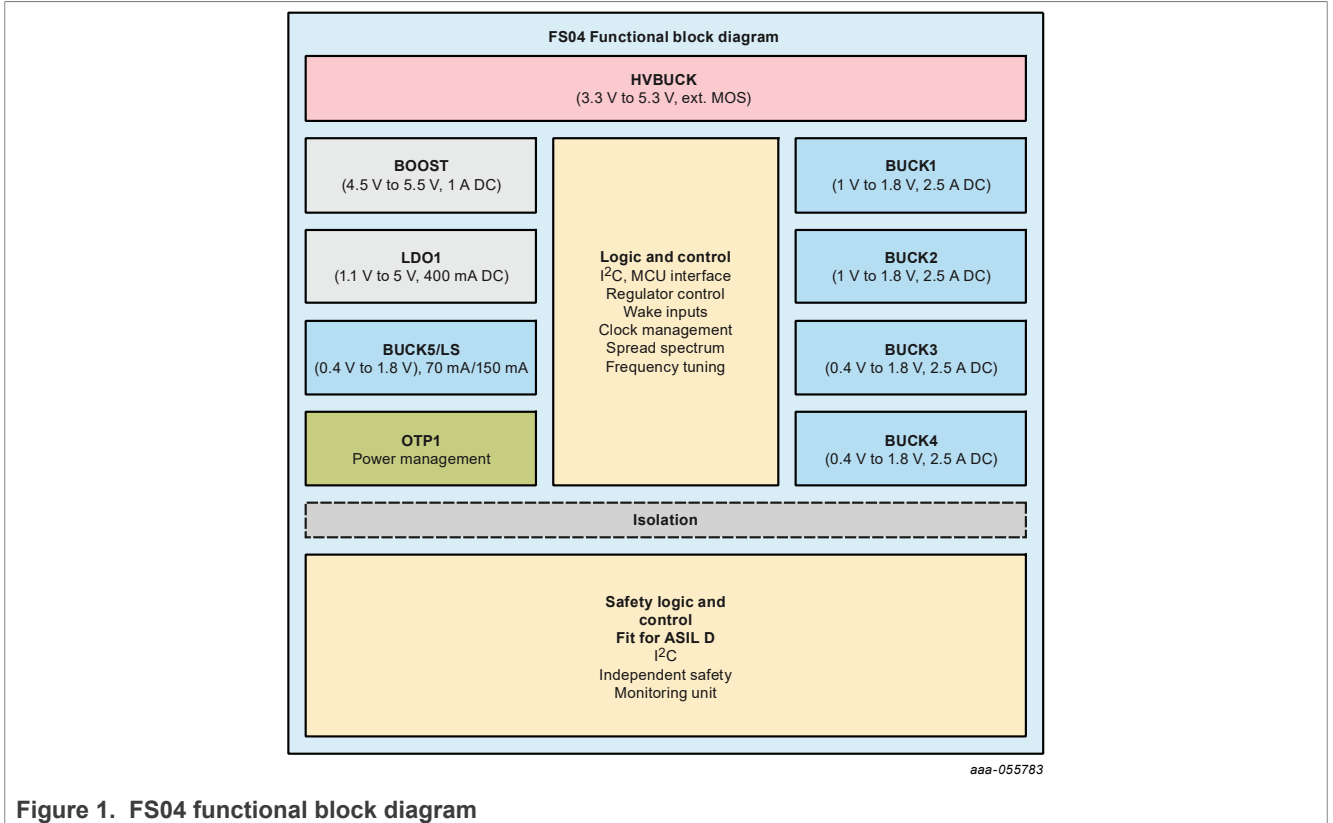

Figure 1. FS04 functional block diagram

5.2 Power rail summary

Table 3. Voltage regulator summary

Regulator	Type	Input Supply	Output Range	Output current
HVBUCK	High-voltage buck controller	2.7 V to 60 V	3.3 V to 5.3 V	20 A DC
BUCK1	Single-phase buck regulator	2.5 V to 5.5 V	1 V to 1.8 V	2.5 A DC
BUCK2	Single-phase buck regulator	2.5 V to 5.5 V	1 V to 1.8 V	2.5 A DC
BUCK3	Single-phase buck regulator	2.5 V to 5.5 V	0.4 V to 1.8 V	2.5 A DC
BUCK4	Single-phase buck regulator	2.5 V to 5.5 V	0.4 V to 1.8 V	2.5 A DC
BUCK5	Single-phase buck regulator	0.6 V to 5.5 V	0.6 V to 1.8 V	70 mA / 150 mA DC
LDO1	LDO with load switch	2.5 V to 5.5 V	1.1 V to 3.3 V	400 mA DC
BOOST	Boost regulator	2.7 V to 6 V	4.5 V to 5.5 V	1 A DC

5.3 Thermal characteristics

Table 4. Thermal characteristics

Symbol	Description	Min	Typ	Max	Units
T_A	Ambient operating yemperature • Grade 1 ^[1]	-40		125	°C
T_J	Junction temperature	-40		150	°C
T_{ST}	Storage temperature range	-55		150	°C

[1] Maximum T_A will depend on the overall power dissipated on the device.

6 Revision history

Table 5. Revision history

Document ID	Release date	Description
FS04_PB v.1.0	11 June 2024	Initial version

Legal information

Definitions

Draft — A draft status on a document indicates that the content is still under internal review and subject to formal approval, which may result in modifications or additions. NXP Semiconductors does not give any representations or warranties as to the accuracy or completeness of information included in a draft version of a document and shall have no liability for the consequences of use of such information.

Disclaimers

Limited warranty and liability — Information in this document is believed to be accurate and reliable. However, NXP Semiconductors does not give any representations or warranties, expressed or implied, as to the accuracy or completeness of such information and shall have no liability for the consequences of use of such information. NXP Semiconductors takes no responsibility for the content in this document if provided by an information source outside of NXP Semiconductors.

In no event shall NXP Semiconductors be liable for any indirect, incidental, punitive, special or consequential damages (including - without limitation - lost profits, lost savings, business interruption, costs related to the removal or replacement of any products or rework charges) whether or not such damages are based on tort (including negligence), warranty, breach of contract or any other legal theory.

Notwithstanding any damages that customer might incur for any reason whatsoever, NXP Semiconductors' aggregate and cumulative liability towards customer for the products described herein shall be limited in accordance with the Terms and conditions of commercial sale of NXP Semiconductors.

Right to make changes — NXP Semiconductors reserves the right to make changes to information published in this document, including without limitation specifications and product descriptions, at any time and without notice. This document supersedes and replaces all information supplied prior to the publication hereof.

Applications — Applications that are described herein for any of these products are for illustrative purposes only. NXP Semiconductors makes no representation or warranty that such applications will be suitable for the specified use without further testing or modification.

Customers are responsible for the design and operation of their applications and products using NXP Semiconductors products, and NXP Semiconductors accepts no liability for any assistance with applications or customer product design. It is customer's sole responsibility to determine whether the NXP Semiconductors product is suitable and fit for the customer's applications and products planned, as well as for the planned application and use of customer's third party customer(s). Customers should provide appropriate design and operating safeguards to minimize the risks associated with their applications and products.

NXP Semiconductors does not accept any liability related to any default, damage, costs or problem which is based on any weakness or default in the customer's applications or products, or the application or use by customer's third party customer(s). Customer is responsible for doing all necessary testing for the customer's applications and products using NXP Semiconductors products in order to avoid a default of the applications and the products or of the application or use by customer's third party customer(s). NXP does not accept any liability in this respect.

Limiting values — Stress above one or more limiting values (as defined in the Absolute Maximum Ratings System of IEC 60134) will cause permanent damage to the device. Limiting values are stress ratings only and (proper) operation of the device at these or any other conditions above those given in the Recommended operating conditions section (if present) or the Characteristics sections of this document is not warranted. Constant or repeated exposure to limiting values will permanently and irreversibly affect the quality and reliability of the device.

Terms and conditions of commercial sale — NXP Semiconductors products are sold subject to the general terms and conditions of commercial sale, as published at <https://www.nxp.com/profile/terms>, unless otherwise agreed in a valid written individual agreement. In case an individual agreement is concluded only the terms and conditions of the respective agreement shall apply. NXP Semiconductors hereby expressly objects to applying the customer's general terms and conditions with regard to the purchase of NXP Semiconductors products by customer.

No offer to sell or license — Nothing in this document may be interpreted or construed as an offer to sell products that is open for acceptance or the grant, conveyance or implication of any license under any copyrights, patents or other industrial or intellectual property rights.

Quick reference data — The Quick reference data is an extract of the product data given in the Limiting values and Characteristics sections of this document, and as such is not complete, exhaustive or legally binding.

Export control — This document as well as the item(s) described herein may be subject to export control regulations. Export might require a prior authorization from competent authorities.

Translations — A non-English (translated) version of a document, including the legal information in that document, is for reference only. The English version shall prevail in case of any discrepancy between the translated and English versions.

Security — Customer understands that all NXP products may be subject to unidentified vulnerabilities or may support established security standards or specifications with known limitations. Customer is responsible for the design and operation of its applications and products throughout their lifecycles to reduce the effect of these vulnerabilities on customer's applications and products. Customer's responsibility also extends to other open and/or proprietary technologies supported by NXP products for use in customer's applications. NXP accepts no liability for any vulnerability. Customer should regularly check security updates from NXP and follow up appropriately.

Customer shall select products with security features that best meet rules, regulations, and standards of the intended application and make the ultimate design decisions regarding its products and is solely responsible for compliance with all legal, regulatory, and security related requirements concerning its products, regardless of any information or support that may be provided by NXP.

NXP has a Product Security Incident Response Team (PSIRT) (reachable at PSIRT@nxp.com) that manages the investigation, reporting, and solution release to security vulnerabilities of NXP products.

Suitability for use in automotive applications (functional safety) —

This NXP product has been qualified for use in automotive applications. It has been developed in accordance with ISO 26262, and has been ASIL classified accordingly. If this product is used by customer in the development of, or for incorporation into, products or services (a) used in safety critical applications or (b) in which failure could lead to death, personal injury, or severe physical or environmental damage (such products and services hereinafter referred to as "Critical Applications"), then customer makes the ultimate design decisions regarding its products and is solely responsible for compliance with all legal, regulatory, safety, and security related requirements concerning its products, regardless of any information or support that may be provided by NXP. As such, customer assumes all risk related to use of any products in Critical Applications and NXP and its suppliers shall not be liable for any such use by customer. Accordingly, customer will indemnify and hold NXP harmless from any claims, liabilities, damages and associated costs and expenses (including attorneys' fees) that NXP may incur related to customer's incorporation of any product in a Critical Application.

NXP B.V. — NXP B.V. is not an operating company and it does not distribute or sell products.

Trademarks

NXP — wordmark and logo are trademarks of NXP B.V.

Notice: All referenced brands, product names, service names, and trademarks are the property of their respective owners.

Tables

Tab. 1.	Ordering information	5	Tab. 4.	Thermal characteristics	7
Tab. 2.	Ordering part number and OTP version	5	Tab. 5.	Revision history	8
Tab. 3.	Voltage regulator summary	6			

Figures

Fig. 1. FS04 functional block diagram6

Contents

1	Overview	2
2	Features	3
3	Applications	4
4	Ordering information	5
5	Device description	6
5.1	Functional block diagram	6
5.2	Power rail summary	6
5.3	Thermal characteristics	7
6	Revision history	8
	Legal information	9

Please be aware that important notices concerning this document and the product(s) described herein, have been included in section 'Legal information'.

© 2024 NXP B.V.

All rights reserved.

For more information, please visit: <https://www.nxp.com>

Date of release: 11 June 2024
Document identifier: FS04_PB