



Power Grid Converter

Last Updated: Sep 5, 2024

Electricity grid, electrical grid or power grid is the network comprised by the generators, transmission lines, transformers, substation and distribution lines that deliver power to the consumer. Concentrators are important part of the metering system in a state grid which collect power consumption information downward from power meters and collectors.

NXP offers the different products need to build and connect a concentrator such as support for various communication protocols including RS-485, 470MHz Sub-G wireless system, Power Line Carrier (PLC-Broadband and narrowband carrier), Ethernet, 2G/3G/4G, and State Grid VPN.

Power Grid Concentrator Block Diagram

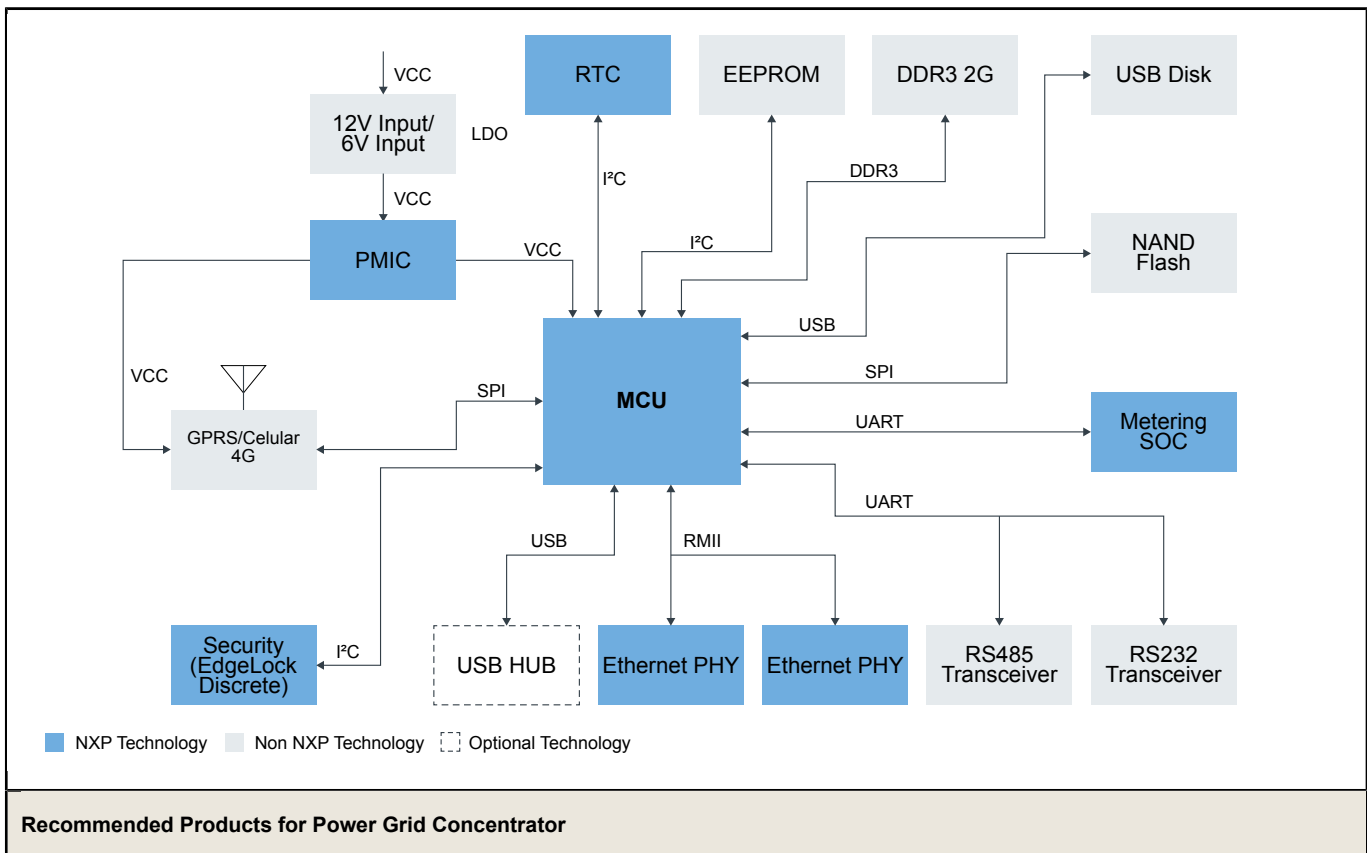

MCU	<ul style="list-style-type: none"> • i.MX6ULL: i.MX 6ULL Single-Core Processor with Arm® Cortex®-A7 Core • KM3x: 50–75 MHz Precision Metrology MCUs with Segment LCDs Based on Arm® Cortex®-M0+
MCU	<ul style="list-style-type: none"> • i.MX6ULL: i.MX 6ULL Single-Core Processor with Arm® Cortex®-A7 Core • KM3x: 50–75 MHz Precision Metrology MCUs with Segment LCDs Based on Arm® Cortex®-M0+
Power Management	<ul style="list-style-type: none"> • PF3001: 10-Channel Configurable PMIC for i.MX6 and i.MX7 Application Processors
RTC	<ul style="list-style-type: none"> • PCA2131: Nano-Power Highly Accurate RTC with Integrated Quartz Crystal for Automotive Applications
Security (EdgeLock Discrete)	<ul style="list-style-type: none"> • SE050: EdgeLock® SE050: Plug and Trust Secure Element Family – Enhanced IoT Security with High Flexibility
Transceiver	<ul style="list-style-type: none"> • SC16C650B: 5 V, 3.3 V and 2.5 V UART with 32-byte FIFOs and Infrared (IrDA) Encoder/Decoder • TJA1101: TJA1101B, IEEE 100BASE-T1 Compliant Automotive Ethernet PHY Transceiver

View our complete solution for [Power Grid Converter](#).

Note: The information on this document is subject to change without notice.

www.nxp.com

NXP and the NXP logo are trademarks of NXP B.V. All other product or service names are the property of their respective owners. The related technology may be protected by any or all of patents, copyrights, designs and trade secrets. All rights reserved. © 2024 NXP B.V.