



# Motor Control Design Based on LPC860 MCUs

## MCD-LPC860-MCU

Last Updated: Apr 23, 2024

This motor control reference design based on the LPC860 includes PMSM flux orientation control and BLDC motor commutation control. Leveraging the flextimer and ADC module, LPC860 provides a complete set of peripherals required for motor control that are suitable for home appliance applications with a three-phase motor or multiple DC brushed motors.

The motor control reference design uses the LPCXpresso860-MAX evaluation kit and FRDM motor control development kit, which includes FRDM-MC-LVPMSM and FRDM-MC-BLDC driver board to drive a motor. The controller uses Flextimer (FTM) to generate PWM signal and trigger the ADC to run the motor control algorithm in an interrupt after ADC sampling is completed, leveraging NXP's RECESL control algorithm library.

For more detail, please visit [AN14017](#) and [AN14018](#).

## Motor Control Design Block Diagram

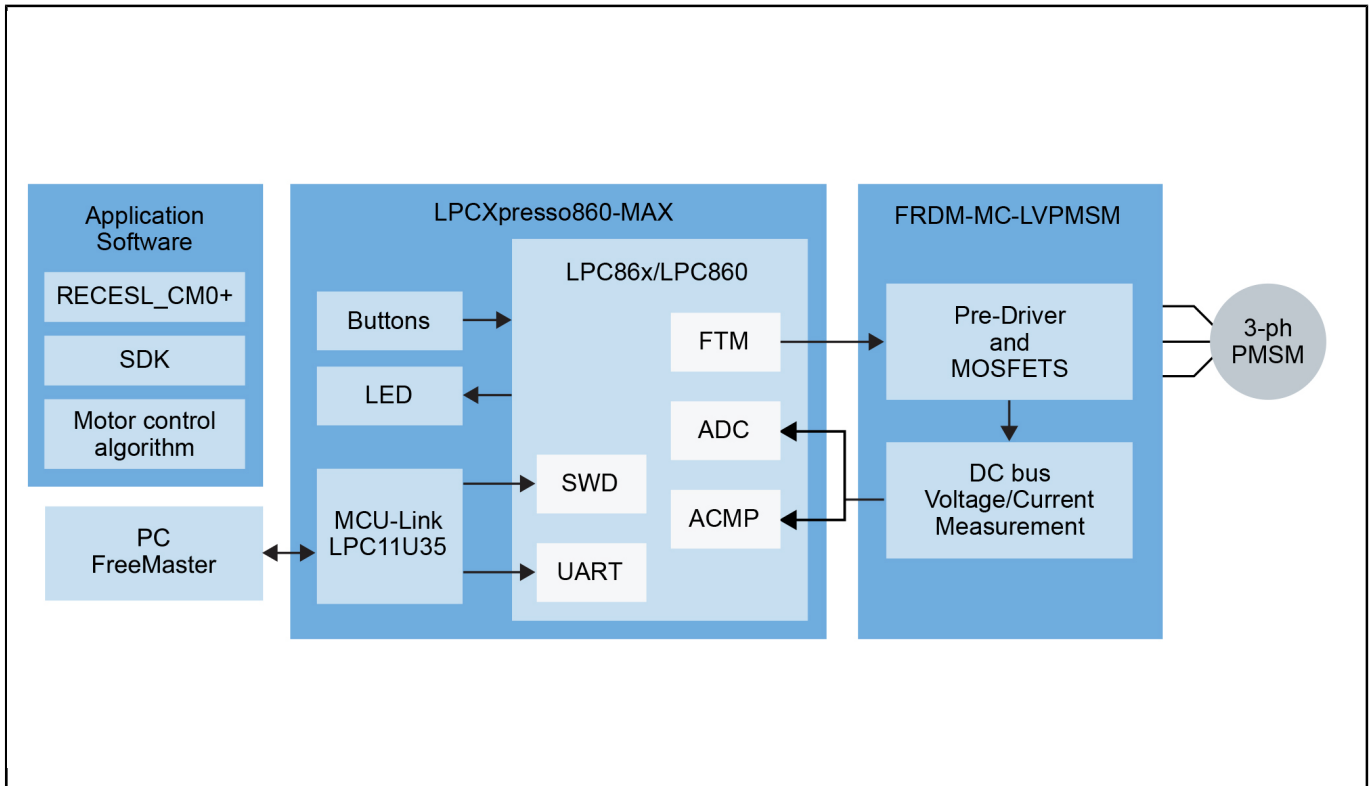

View additional information for [Motor Control Design Based on LPC860 MCUs](#).

**Note:** The information on this document is subject to change without notice.

**www.nxp.com**

NXP and the NXP logo are trademarks of NXP B.V. All other product or service names are the property of their respective owners. The related technology may be protected by any or all of patents, copyrights, designs and trade secrets. All rights reserved. © 2024 NXP B.V.