



MAPS-56F84000 Evaluation Suite

MAPS-56F84000

Last Updated: Nov 29, 2022

The MAPS-56F84000 evaluation suite is a full-featured, multi-function development platform for the 56F84xxx digital signal controller (DSC). This suite includes a controller board with MC56F84789VLL on board and a motor control driver board which can drive dual PMSM motor at the same time. Use this suite to evaluate the exciting performance of NXP's powerful DSC products customized for motor control applications.

MC56F84XX Digital Signal Controllers Block Diagram Block Diagram

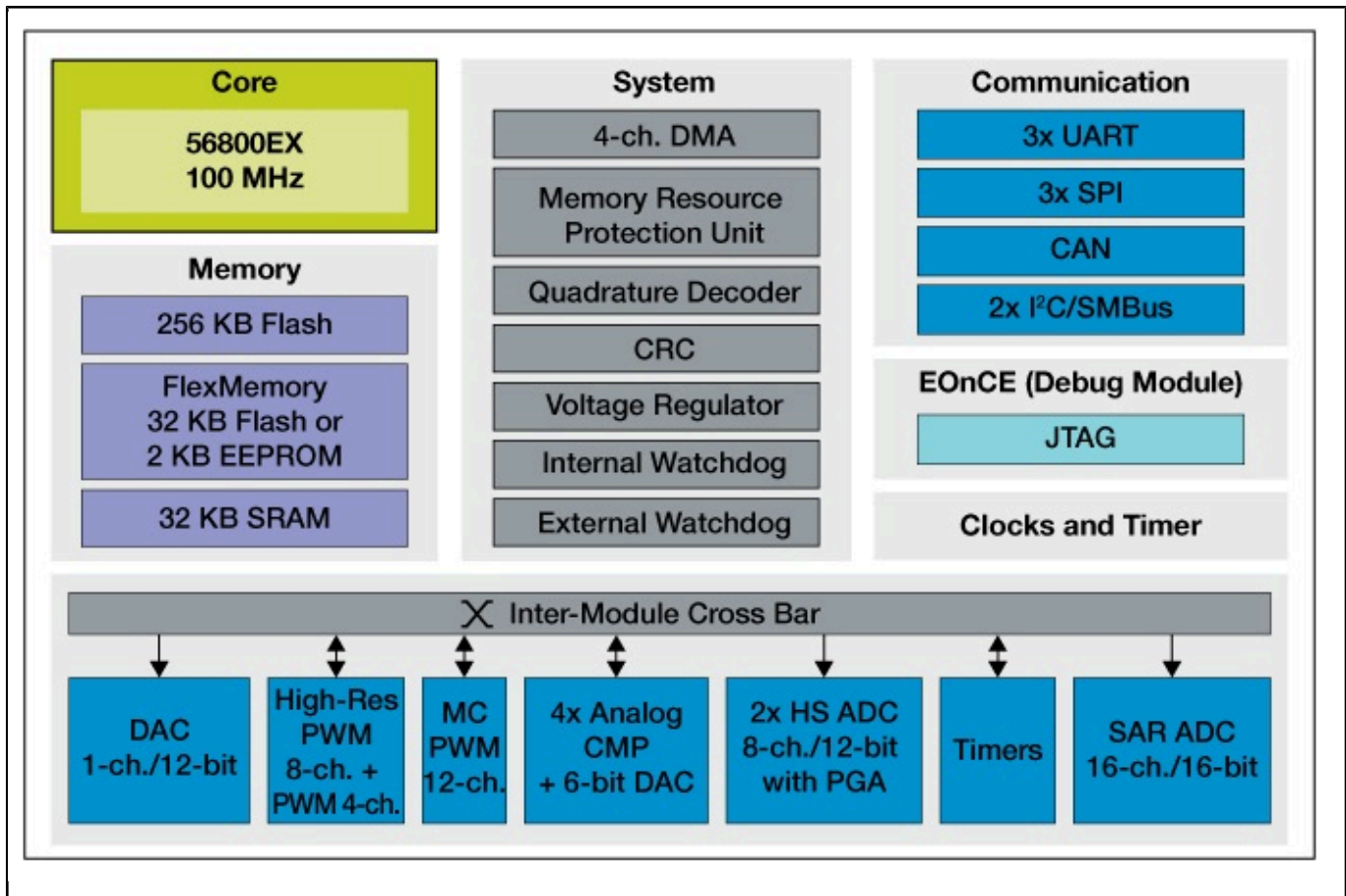

MAPS-56G84000 controller board Block Diagram

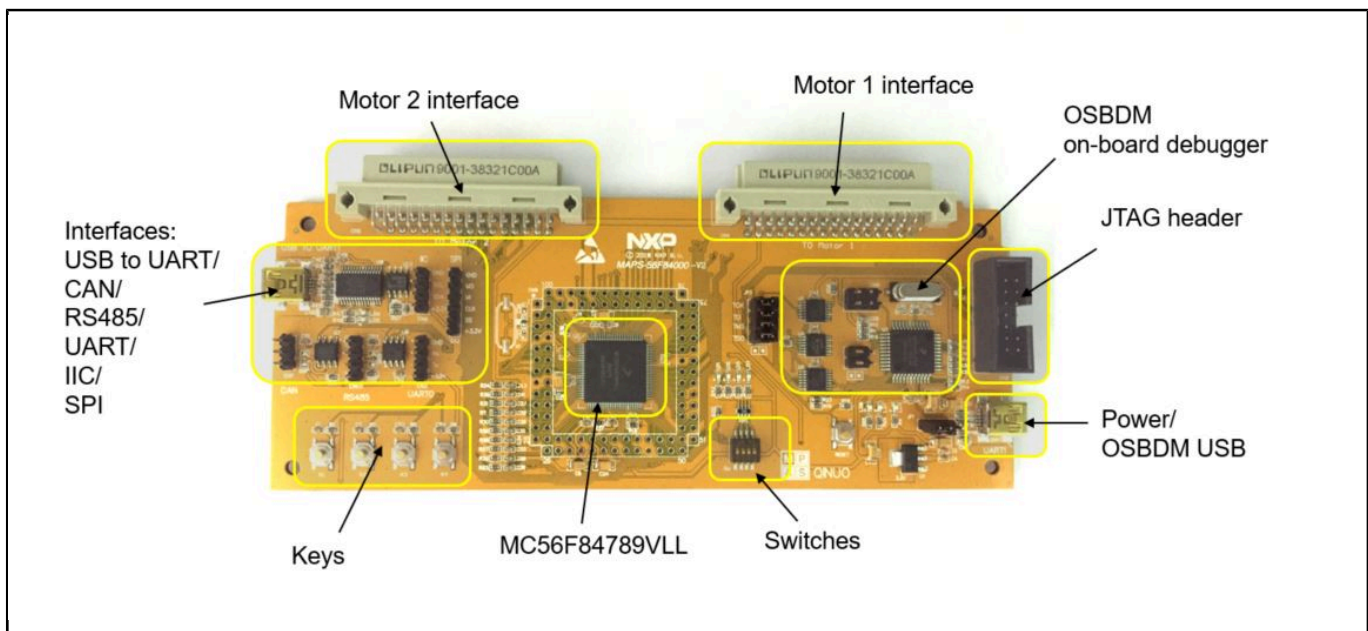

MAPS-MC-2IN1 dual motor driver board Block Diagram

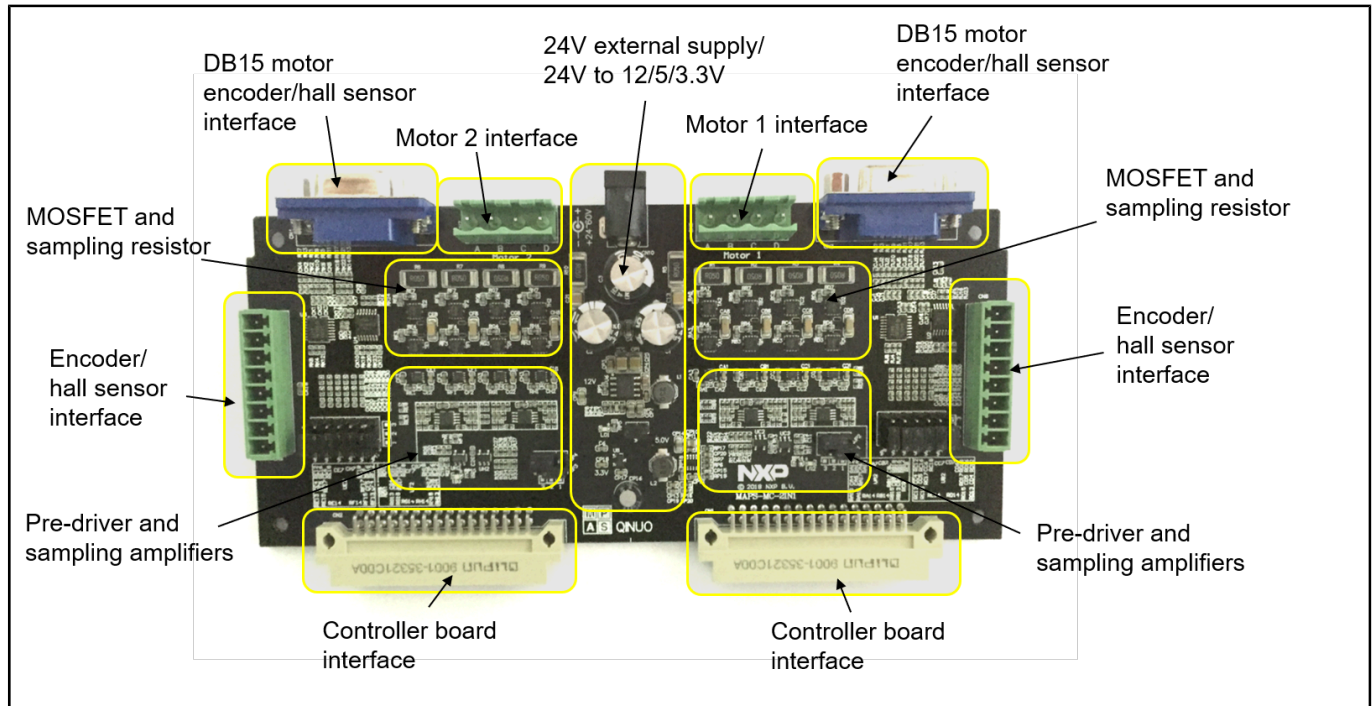

View additional information for [MAPS-56F84000 Evaluation Suite](#).

Note: The information on this document is subject to change without notice.

www.nxp.com

NXP and the NXP logo are trademarks of NXP B.V. All other product or service names are the property of their respective owners. The related technology may be protected by any or all of patents, copyrights, designs and trade secrets. All rights reserved. © 2024 NXP B.V.