



# BYLink Multiprocessor Demo Board

## DEMO-BYL1-EVB

Last Updated: Jun 5, 2024

The DEMO-BYL1-EVB is a demonstrator design to illustrate the BYLink concept power management solution proposed by NXP for ADAS and multiprocessor automotive applications. The solution integrates NXP PMIC such as FS8500, PF5024 and PF5020 as a single power solution for a camera application involving a safety MCU and a processing MCU.

The DEMO-BYL1-EVB kit provides full access to all the features of each PMIC device, such as OTP configuration, power sequencing and safety features. The demonstrator kit comes with a USB cable used as a communication interface between computer and BYLink concept to have control on the full PMIC solution.

# BYLink Tool Block Diagram

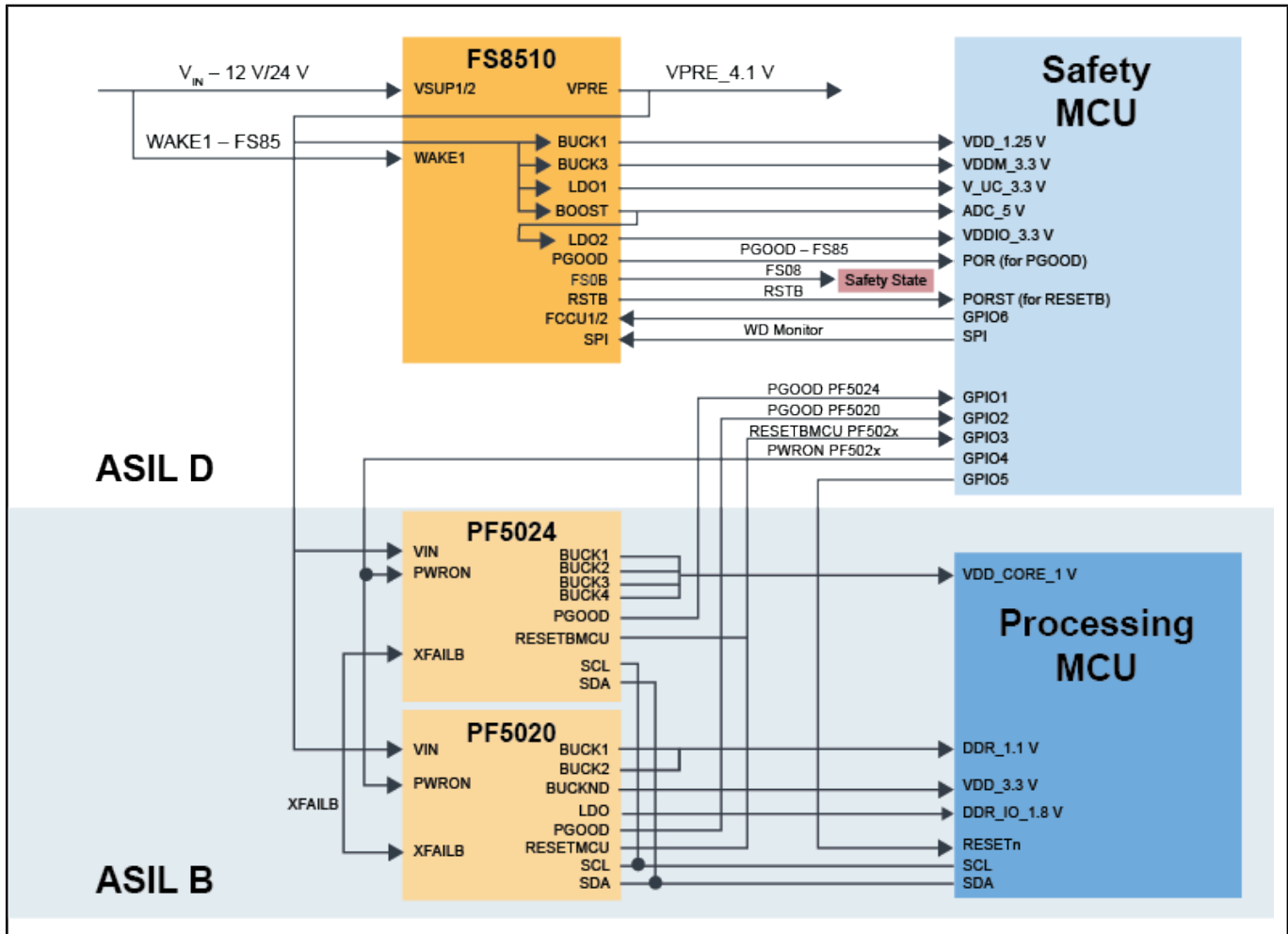

View additional information for [BYLink Multiprocessor Demo Board](#).

**Note:** The information on this document is subject to change without notice.

[www.nxp.com](http://www.nxp.com)

NXP and the NXP logo are trademarks of NXP B.V. All other product or service names are the property of their respective owners. The related technology may be protected by any or all of patents, copyrights, designs and trade secrets. All rights reserved. © 2024 NXP B.V.