



Brushless DC Motor (BLDC) Control

Last Updated: Oct 13, 2021

The brushless DC (BLDC) motor is also referred to as an electronically commutated motor. There are no brushes on the rotor and commutation is performed electronically at certain rotor positions. The stator magnetic circuit is usually made from magnetic steel sheets. One of the recently popular brushless motor control techniques is Field Oriented Control (FOC).

NXP's broad portfolio and extensive documentation allows you to ease the development effort for BLDC control applications.

Sensorless Control / Sensored Control Block Diagram

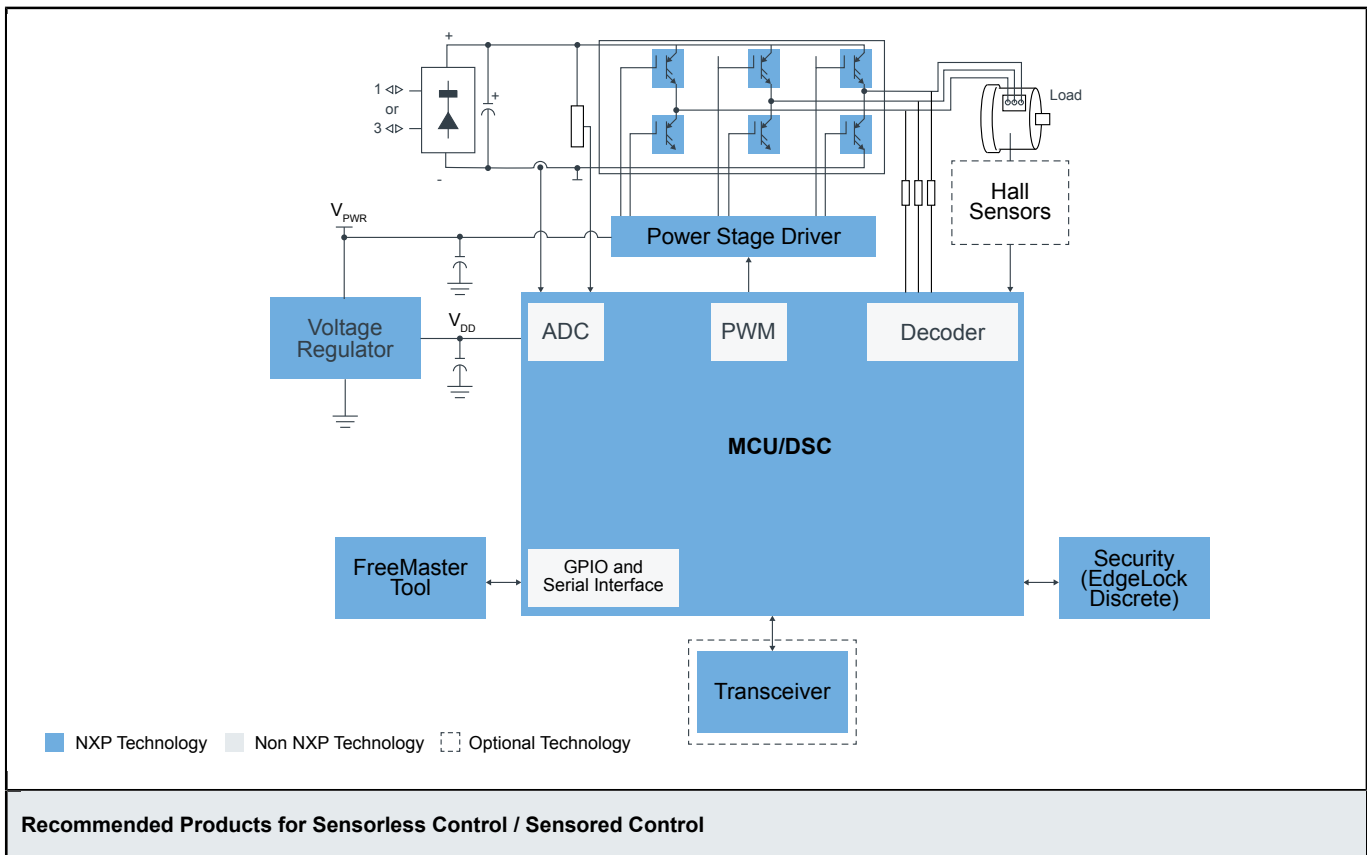

MCU/DSC	<ul style="list-style-type: none"> • S32K3 Microcontrollers for General Purpose • KV Series Cortex-M4/M0+/M7: KV Series: Real-time Motor Control and Power Conversion MCUs based on Arm® Cortex®-M0+/M4/M7 • MC56F84xxx: Digital Signal Controllers • MC56F83xxx: Performance Level Digital Signal Controllers, USB FS OTG, CAN-FD • MC56F82xxx: MC56F826xx and MC56F827xx Digital Signal Controllers
Power Stage Driver	<ul style="list-style-type: none"> • GD3000: 3-Phase Brushless Motor Pre-Driver • MC33937: 3-Phase Field Effect Transistor Pre-driver
Voltage regulator	<ul style="list-style-type: none"> • MC33730: Power Supply with Multiple Linear Regulators • TJA1042: High-Speed CAN Transceiver with Standby Mode • MC33903: SBC Gen2 with High-Speed CAN and LIN • MC33904: System Basis Chip Gen2 with High Speed CAN • MC33905: SBC Gen2 with High-Speed CAN and LIN • MC34717: 5.0A 1.0MHz Integrated Dual Switch-Mode Power Supply
Software	<ul style="list-style-type: none"> • FreeMASTER Run-Time Debugging Tool • RTCESL: Real Time Control Embedded Software Motor Control and Power Conversion Libraries • Model-Based Design Toolbox (MBDT)
Transceiver	<ul style="list-style-type: none"> • TJA1044: High-Speed CAN Transceiver with Standby Mode - Mantis Family • TJA1462: CAN Signal Improvement Capability Transceiver with Standby Mode
Security (EdgeLock Discrete)	<ul style="list-style-type: none"> • EdgeLock® SE050: Plug & Trust Secure Element Family – Enhanced IoT security with maximum flexibility

View our complete solution for [Brushless DC Motor \(BLDC\) Control](#).

Note: The information on this document is subject to change without notice.

www.nxp.com

NXP and the NXP logo are trademarks of NXP B.V. All other product or service names are the property of their respective owners. The related technology may be protected by any or all of patents, copyrights, designs and trade secrets. All rights reserved. © 2021 NXP B.V.