

# Benefits and Applications Enabled by Expanded 56F8000 Digital Signal Controllers

by: John Winters

## 1 Introduction

### 1.1 Overview

The new *expanded* 56F8000 series is the latest addition to the DSC portfolio of high-performance, Flash-based processors. They provide new ways to further reduce the total-system cost of intelligent multi-phase power-control applications—emboldening even the most reluctant analog engineers to plunge into low cost digital solutions. The expanded 56F8000 series achieves this with:

- Integration of *even more analog modules*—Analog Comparators, Digital to Analog converters remove the last vestige of fear for analog engineers and allow even more components to be eliminated from the system bill of materials
- Exceptional integration of powerful internal peripherals—more timers, more packages with

### Contents

1	Introduction	1
1.1	Overview	1
2	Applications Enabled by the 56F8000 Digital Signal Controller	9
2.1	High Performance Power Factor Correction and Rectification	9
2.2	DC-to-DC Switched-Mode Power Supply	10
2.3	Digital Dimmable Lighting Ballast	12
2.4	Low-Cost Sensorless 3-Phase Motor Control	13
2.5	Wireless Battery-Powered Sensor Application	19
3	Conclusion	20

**Introduction**

- more pins, significantly lowers system costs and enables new applications at lower cost
- High-performance, reliable internal Flash memory—offers flexibility in development, production and inventory with the reliability and performance traditionally associated with read-only memory
- High 32 MHz / 32 MIPS performance—enables a broad range of applications at a lower cost
- Hybrid MCU / DSP core architecture—speeds development and lowers component count
- Integrated safety features for high reliability—creates safer, lower-risk, more reliable end products
- Extended temperature operation—allows innovative end products that can be used in the harshest environments
- Powerful, award-winning CodeWarrior™ Integrated Development Environment—lowers software development costs and frees software developers
- Innovative Processor Expert™ rapid application development tool—dramatically speeds the developer’s learning curve and software development

These elements mean that the expanded 56F8000 series of components is ideally suited for a broad range of industrial, consumer, and automotive applications. The expanded 56F8000 Series is a part of the greater Freescale Embedded Flash portfolio, as shown in Figure 1. With the introduction of the expanded 56F8000 series, Freescale has provided a new level of price, performance, and integration to Flash-based products. The expanded 56F8000 series provides current 8/16-bit MCU and 56800/E customers with an excellent path to improved price / performance and features. The lower cost, enhanced peripheral performance and features of the expanded 56F8000 series enable a developer to expand his horizons with new product possibilities. This white paper shows only a few of the applications made possible and practical using the new price / performance-leading expanded 56F8000 controllers from Freescale.

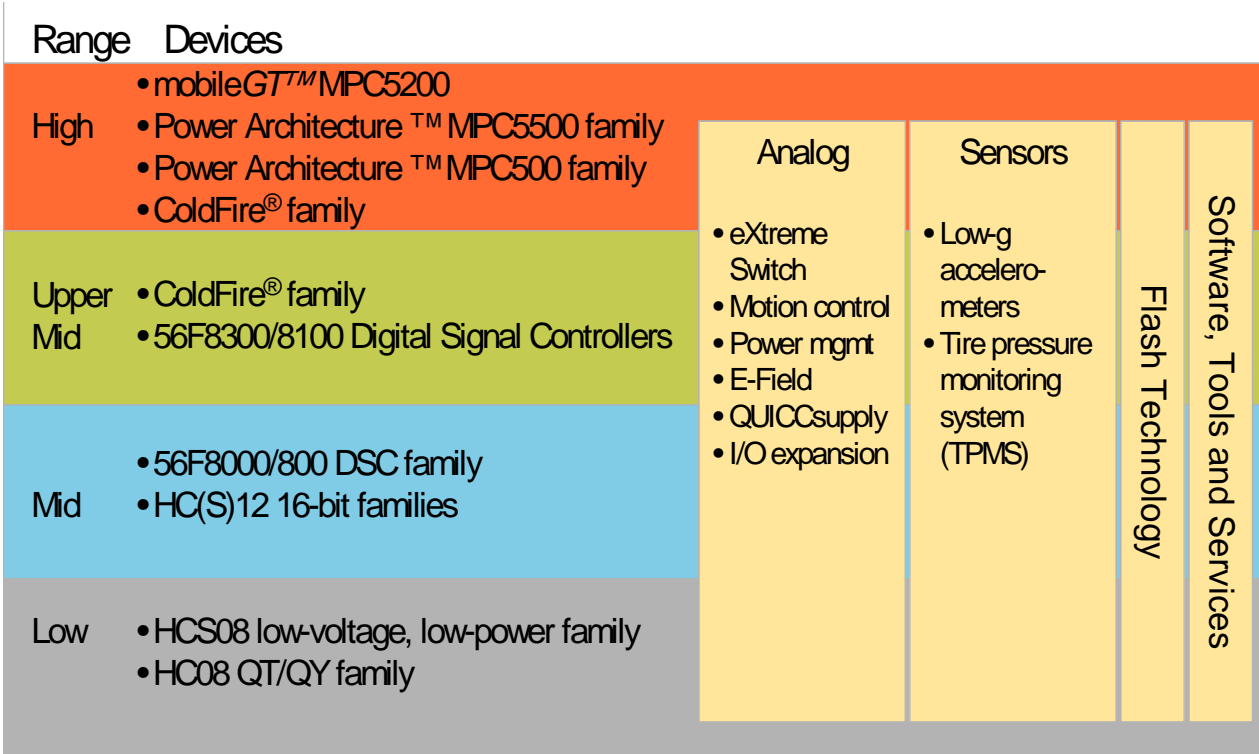

**Figure 1. Freescale’s Controller Continuum**

Figure 2 illustrates the broad portfolio of 56800/E components; all are code compatible. The expanded 56F800 series is based on the original 56800 core and offers the best of both MCU and DSP functionality. The 56F8000 series is based around the enhanced version of the 56800 core, the 56800E core, and offers improved DSP and MCU performance, as well as improved MCU capability. The expanded 56F8000 series is an expansion of the 56F8000 series. The 56F8300 / 8100 series of components offers higher core performance and 32-bit performance. The 56850 series is RAM-based and targeted for high-performance voice, multimedia, telecommunications, and hybrid networking applications.

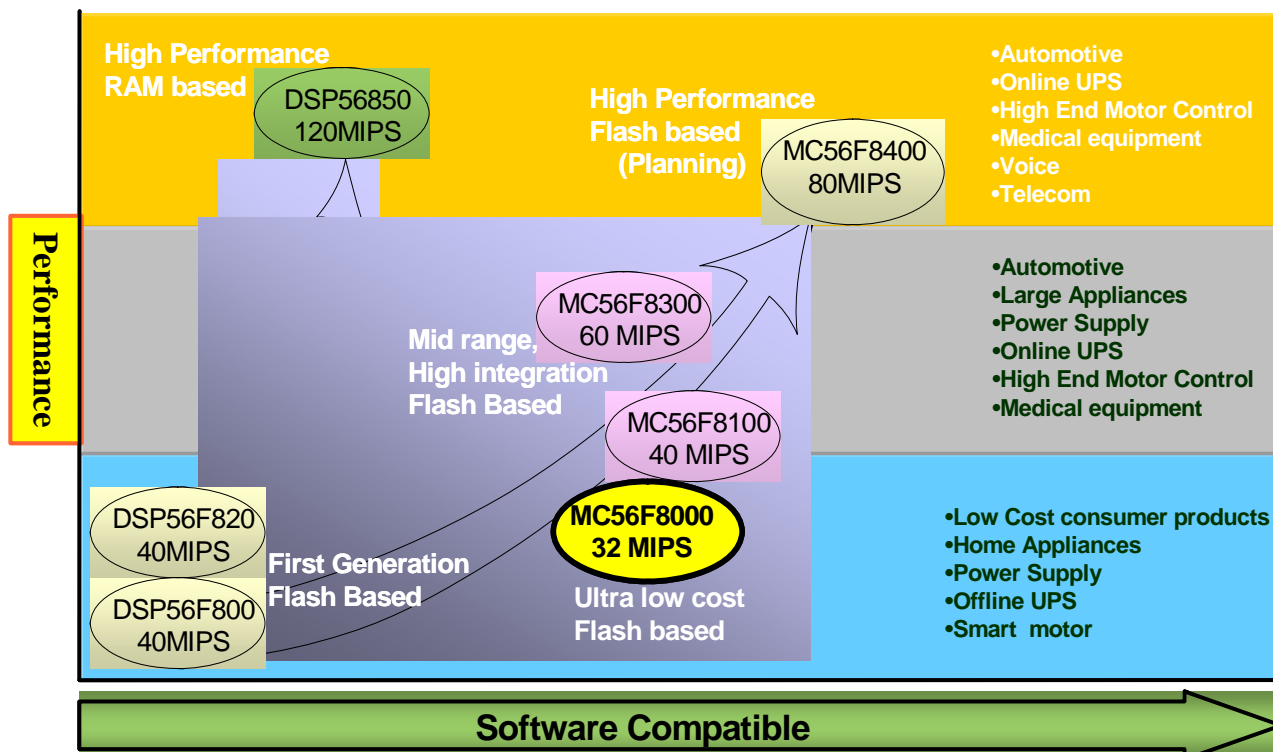

Figure 2. Freescale’s Digital Signal Controller Portfolio

The expanded 56F8000 devices are very cost-effective controllers in the portfolio while offering very high-performance peripherals and more memory. The components in the expanded 56F8000 series have a broad range of package, memory, and peripheral configurations. Table 1 and Figure 3 show the details of the expanded 56F8000 portfolio.

**Table 1. Expanded 56F8000 Portfolio Details**

Feature	56F8023	56F8025	56F8036	56F8037
Performance	32 MIPs	32 MIPs	32 MIPs	32 MIPs
Temperature Range <sup>1</sup>	-40°C to +105°C -40°C to +125°C	-40°C to +105°C -40°C to +125°C	40°C to +105°C -40°C to +125°C	40°C to +105°C -40°C to +125°C
Voltage Range	3.0 V - 3.6 V	3.0 V - 3.6 V	3.0 V - 3.6 V	3.0 V - 3.6 V
Program Flash	32 KB	32 KB	64 KB	64 KB
Unified RAM	4 KB	4 KB	8 KB	8 KB
Flash Security	Yes	Yes	Yes	Yes
External Memory Interface	No	No	No	No
Voltage Regulator	On-Chip	On-Chip	On-Chip	On-Chip
On-Chip Relaxation Oscillator	Yes	Yes	Yes	Yes
16 bit Timer	4	4	4	8
Programmable Interval Timer	1	3	3	3
PWM	1 × 6 channel	1 × 6 channel	1 × 6 channel	1 × 6 channel
PWM Fault Input	4	4	4	4
12-bit ADC	2 × 3 channel	2 × 4 channel	2 × 5 channel	2 × 8 channel
12-bit DAC	2 (internal)	2 (internal)	2 (internal)	2 (external <sup>2</sup> )
Analog Comparator	2	2	2	2
IIC	1	1	1	1
QSCI (UART) / LIN Slave	1	1	1	2
QSPI (Synchronous)	1	1	1	2
GPIO (Maximum)	26	35	39	53
CAN	No	No	MSCAN	MSCAN
JTAG / EOnCE	Yes	Yes	Yes	Yes
Package	32 LQFP .8p	44 LQFP .8p	48 LQFP .5p	64 LQFP .5p

<sup>1</sup> Upper temperature ranges are **not** available at time of publication.

<sup>2</sup> On a pin of the device

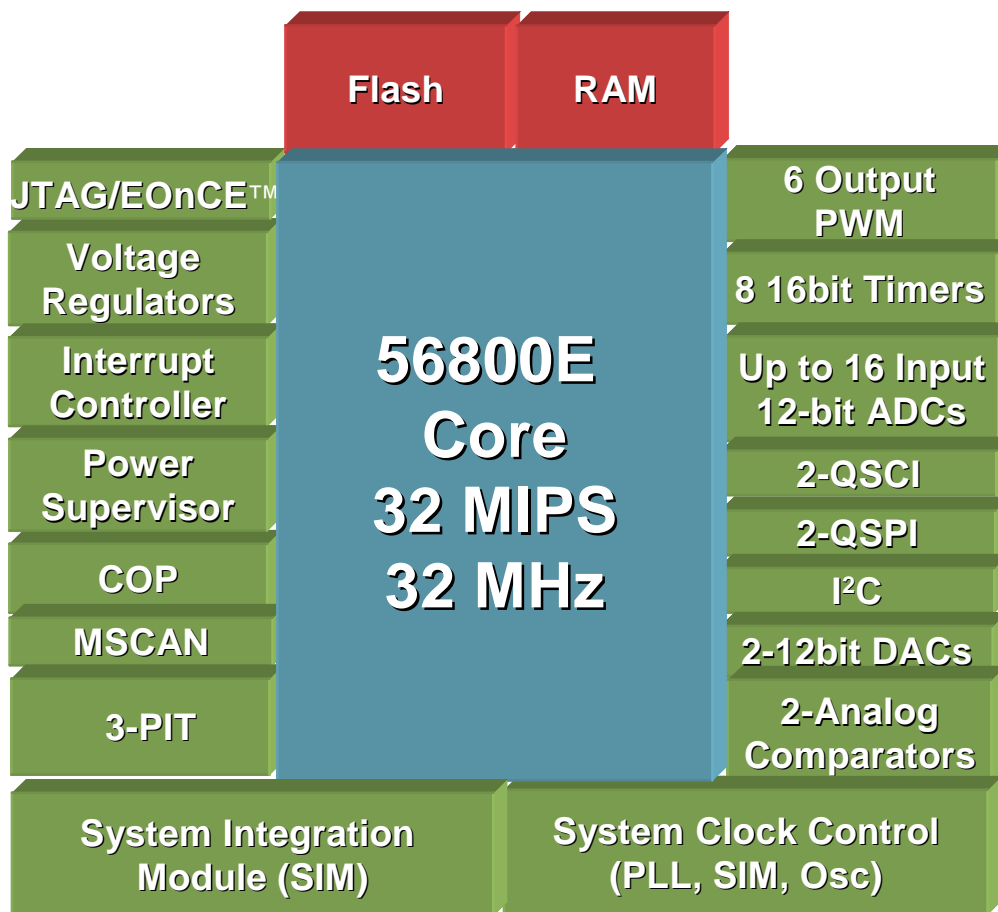

**Figure 3. 56F8037 Block Diagram**

The 56F8000 series offers an excellent complement of peripherals and a broad range of memory and packages. Some of the 56F8000 series' benefits include:

- High-performance 56800E core
  - Superior 16-bit, fixed-point signal processing performance provided by the bus architecture and the controller core
  - Excellent control and protocol processing capability and code density
  - Superior MCU control performance
- Performance-leading Flash memory
  - Unbeatable, field-proven reliability in the harshest environments
  - Features that enable emulation of EEPROM
  - Flexible, full in-circuit Flash programmability
  - Performance-enhancing interfacing and bus structure, enabling the superior signal processing capability from Flash
  - Flash security protection features for IP protection
- Voltage regulator and power supervisor

- The chips come equipped with an on-board voltage regulator and power supervisor. When supplied with a 3.3 V voltage, the chip creates all required internal voltages.
- Includes features such as Power-On Reset (POR) and low-voltage detection, eliminating external components and saving system costs
- On-chip Relaxation Oscillator
  - Some 56F8000 devices are equipped with a precision on-chip, factory-trimmed oscillator (0.25% of 8 MHz), enabling the elimination of an external crystal and providing system cost savings
- On-Chip Clock Synthesis (OCCS)
  - 56F8000 digital signal controllers are capable of using an external clock input
  - The OCCS capability includes a flexible, programmable Phase-Locked Loop (PLL), enabling selection of an exact operating frequency
  - The OCCS also includes unique loss-of-lock detection, allowing the detection of a cut crystal and the proper safety-critical shut down
- 16-bit Timer
  - 56F8000 devices are equipped with powerful timer modules. Each timer module has four independent 16-bit timers that can be:
    - Cascaded
    - Used for input capture
    - Used to generate output waveforms
    - Used to trigger the ADC
    - Used to generate auxiliary PWM waveforms
    - Used as a Digital-to-Analog Converter (DAC) when utilized in conjunction with an external low-pass filter
    - Optionally synchronized together with a common start signal
    - Operated at rates up to 96 MHz
- Programmable Interval Timer
  - 16 bit counter timer
  - Programmable count modulo
  - Max count rate equals peripheral clock rate
  - Slave mode allows synchronization of multiple PIT count enables
- 3-Phase PWM module
  - The high-performance 15-bit PWMs can be used in edge-aligned and center-aligned modes, as well as in complementary and independent modes, and have programmable dead-time generation
  - Excellent resolution with a clock rate of up to 96 Mhz
  - These PWM modules have a sophisticated set of programmable fault lines that do not require a system clock for proper operation
  - These and other features make these PWM modules industry leaders in safety, reliability, and performance

- Enhanced features to support digital power conversion, power factor correction, lighting, and motor control
- Hardware support for advanced phase-shifting PWM techniques
- Analog-to-Digital Converter (ADC) Module
  - Each high-performance 12-bit ADC has two sample and hold circuits, enabling simultaneous or sequential conversion at a rate of up to 1.125  $\mu$ s per conversion
  - ADCs can be used in single-ended or differential modes and have a sophisticated set of unique features, including:
    - Superior absolute accuracy
    - High/low and zero-crossing detection
    - Offset
  - ADCs can be triggered through variety of methods, including PWM synchronization
  - ADCs have a sophisticated set of standby and power down modes for improved low-power performance
  - The ADC's two sample-and-holds circuits can be configured separately to enable two independent sampling rates or start triggers
- Digital-to-Analog Converter (DAC) Module
  - voltage mode with 12 bit resolution
  - 2 $\mu$ s settling time, for rail-to-rail, into 3 K $\Omega$ / 400 pF load
  - Output glitch filter to eliminate switching glitches
  - Choice of update modes
    - Asynchronous - Update on Demand
    - Synchronous
      - Update based on Programmable Interval Timer (PIT)
      - Update based on Timer Overflow
      - Update based on PWM synch signal
- Analog Comparator
  - Continuous-time, differential-input analog comparators with output edge indicators
  - Five internally selectable input sources
    - Three GPIO pins
    - One DAC output
    - One import input from another comparator module
  - The output (whose polarity is programmable) can be internally switched out to
    - a timer input
    - a PWM fault input
    - a PWM source
    - an external output pin
- Inter-Integrated Circuit Serial Bus Interface (I<sup>2</sup>C)

## Introduction

- Compatible with I<sup>2</sup>C bus standard
- Features include:
  - Multi-master operation
  - Software programmable for one of 256 different serial clock frequencies
  - Arbitration lost interrupt with automatic mode switching from master to slave
  - Calling address identification interrupt
- Queued Serial Communication Interface (QSCI)
  - This module operates as a full-duplex Universal Asynchronous Receiver Transmitter (UART)
  - This asynchronous serial interface is queued - with a FIFO
  - Fully interrupt driven and programmable, providing a multitude of operating modes and baud rates
- Queued Serial Peripheral Interface (QSPI)
  - This synchronous serial interface is queued—with a FIFO
  - Operates in wide variety of modes, rates, and bit lengths, enabling the glueless connection to external peripherals and other processors at rates up to 16 Mbps
- General Purpose Input / Output (GPIO)
  - All digital and analog signal pins for the on-board peripherals can also be individually assigned to be GPIO and individually assigned a direction
  - In addition to I/O capability, the GPIO can also generate interrupts
  - Each GPIO has programmable pull-ups
  - The GPIO also has a push-pull mode to efficiently implement a keypad interface
  - 4 mA and 8 mA output-current drive-modes
- Computer Operating Properly (COP)
  - Assists software recovery from runaway code
  - The COP is a free-running down counter which, once enabled, is designed to generate a reset when reaching zero
  - Software must periodically service the COP to clear the counter and prevent a reset
  - The COP enhances end-system reliability and safety
- JTAG/EOnCE™
  - This enhanced on-board emulation module enables true full-rate emulation without the need for expensive hardware emulators
  - To perform powerful, non-intrusive, real-time debugging, simply attach to the processor with the industry-standard JTAG interface

The 56F8000's truly impressive set of features demonstrates why Freescale is the world leader in embedded processors. These components are applicable to a broad range of industrial and automotive applications, such as:

- Compressors
- Smart appliances



- Lighting
- Instrumentation
- Data acquisition
- Metering
- Lifts / elevators / cranes
- HVAC blowers & fans
- Uninterrupted power supplies (UPS)
- Switching mode power supplies (SMPS)
- Analog Control Replacement

## 2 Applications Enabled by the 56F8000 Digital Signal Controller

The 56F8000 series is a very capable product line with excellent performance and a very high level of peripheral and memory integration. In addition, the 56F8000 devices are very affordable. The power and affordability offered by the 56F8000 series enable new applications as well as new features to existing products. This white paper details a few of these applications.

### 2.1 High Performance Power Factor Correction and Rectification

Many products in digital power conversion, such as UPS and AC-to-DC switched-mode power supplies, require a front-end, primary-side, high-performance power factor correction and rectification. In these products, efficiency in rectification, very fine control on the power factor correction, and cost effectiveness, especially in isolating the high and low side voltages, are very important parameters. The 56F8000 is uniquely suited for this type of application. A sample AC-to-DC SMPS is shown in [Figure 4](#). In digital power conversion systems such as these, the AC signal must first be converted to a DC signal to power the inverter. At this stage, active power factor correction is performed by the 56F8000 device. The power factor is the relationship between the AC voltage and the AC current delivered to a load. Loads can appear on the power grid as inductive or capacitive, which produces a phase offset in the voltage and current. This phase offset makes it harder for the power supplier to provide power to the load. The power factor can also be a significant source of noise in the power distribution network, which can cause the performance of the overall system to degrade. As such, it is important in many systems to have precise active power factor correction.

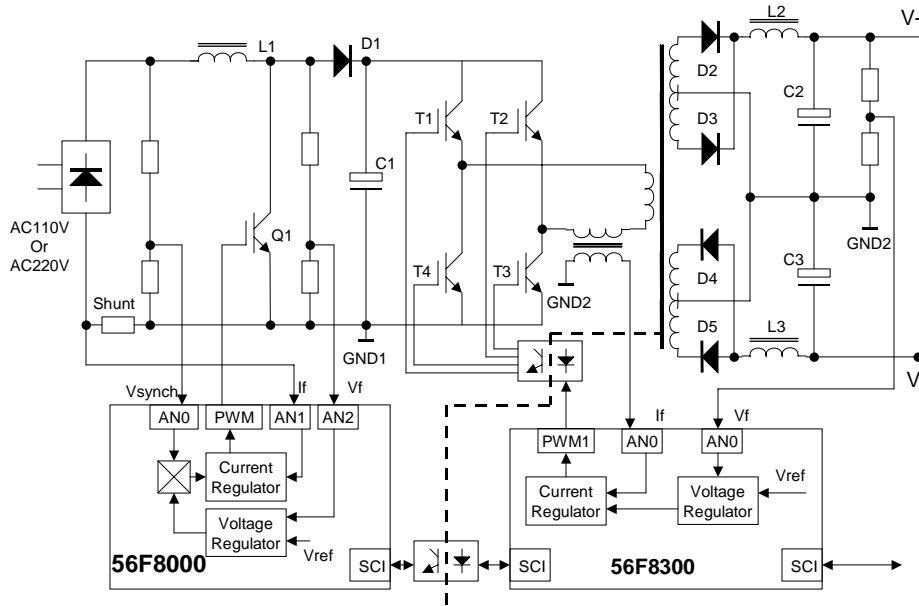

Figure 4. AC-to-DC SMPS with PFC Hardware

The following characteristics make the 56F8000 device uniquely capable of performing active power factor correction:

- High-performance 1.125  $\mu$ s, 12-bit ADC enables a high performance control loop
- 96 MHz PWM and Timers enable precise control of power circuits at high PWM reload rates
- Low cost
- Small devices enable excellent power density

These features allow the 56F8000 device to produce power factor correction that keeps the voltage and current signals continuous in phase and sinusoidal. Often, the AC and DC sides of the power supply must be physically isolated from one another to prevent propagation of an error condition on the AC side to the DC side, maintaining the safety of personnel and equipment on the DC or secondary side (low voltage). As shown in Figure 4, two digital signals of the UART SCI port isolate the AC and DC sides at a very low cost.

The 56F8000 systems allow high-performance PFC, flexibly implemented via software and low-cost, effective isolation.

## 2.2 DC-to-DC Switched-Mode Power Supply

The main purpose of a power supply is to provide clean and stable power to a load, regardless of input power conditions. Switched-Mode Power Supply (SMPS) technology has been widely used in office equipment, computers, communication systems and other applications because of its high efficiency and high energy density.

Presently, the vast majority of SMPS are performed with a mixture of analog and digital control. However, mixed analog / digital implementations have some significant disadvantages that can be rectified by

implementing the SMPS using fully digital mechanisms. Until recently, this has not been cost effective, due to performance and cost of the processors required to do the job. This is especially true of DC-to-DC SMPS, which are very numerous in systems and require a very high speed PWM channel; Timers; ADC channels; low cost; high-performance processing; and small devices. The 56F8000 series of controllers has the required performance, peripherals, and price targets to enable SMPS to make the conversion from mixed analog / digital to fully digital implementations.

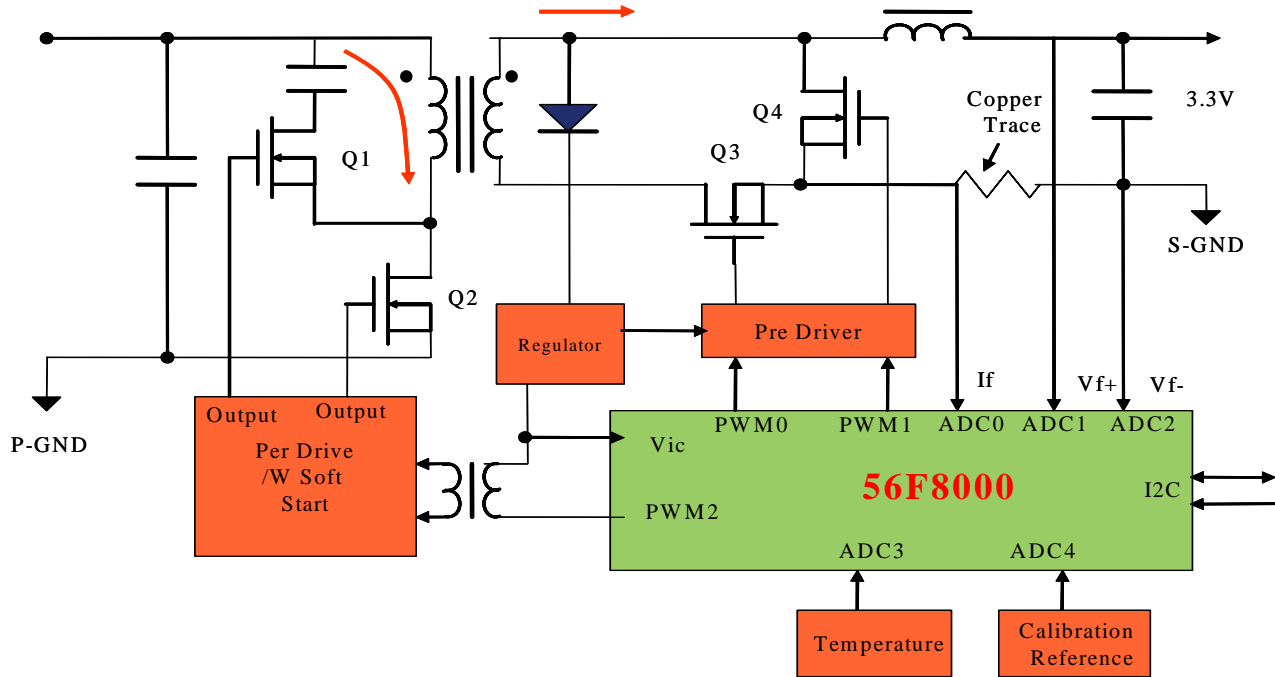

Figure 5. Sample Digital DC-to-DC SMPS

A block diagram for a 56F8000-based DC-to-DC switched-mode power supply is shown in Figure 5. The system shown is a 110-watt, isolated switch-mode, forward type DC-to-DC converter controlled by a 56F8000 on the secondary side. Optional functions may include system communication interfaces using QSPI, SPI, QSCI, SCI, or I<sup>2</sup>C. The module input comes from an adjustable power supply with output range from 36 V DC to 75 V DC and outputs a regulated 3.3 V DC.

Most of the SMPS functionality is now implemented in software in the form of digital control loops. Control functions implemented within the digital signal controller are:

- Monitor input voltage
- Power on/off control
- 3.3V output utilizes average mode current control method
- Power system monitoring and communication protocols
- Intelligent fault and mode management
- Power-up sequence
- Overcurrent roll back (when current limit is reached, control is switched to constant current control)

## Applications Enabled by the 56F8000 Digital Signal Controller

- Hiccup: when overcurrent, overvoltage, or overtemperature is detected, shuts output, then restarts the system

Controlling SMPS with a 56800E device can minimize the number of system components, maximize system reliability and easily add advanced functions without increasing cost. The key advantages of a digitally controlled DC-to-DC SMPS are:

- Power applications become more flexible and universal
- One platform for multiple products
- Intelligent mode management and fault supervision
- Can monitor and control operating status in real time
- Lower system and maintenance cost
- Reduced product development time and cost

The 56F8000 performance, integrated peripherals, and low cost make the digital DC-to-DC SMPS possible and practical.

### 2.3 Digital Dimmable Lighting Ballast

With the introduction of the 56F8000, a new set of control applications is now possible that will revolutionize how power is converted and used. [Figure 6](#) shows a block diagram for a dimmable lighting ballast. This lighting ballast converts the AC power to DC, then reconverts it to an AC signal to power the fluorescent bulb, performing the control function entirely in software. With the flexible control possible through software, the fluorescent bulb can be dimmed under user control via the network interface. The 56F8000 also provides a power factor correction function on the incoming power.

Since the control functions are performed in software, the same hardware can be used to support many different types of bulbs that previously would have required different hardware. The units' manufacture can be simplified by producing a single board with customized software that can be loaded during or after production of the boards. This lowers cost, improves the logistics, and speeds product development.

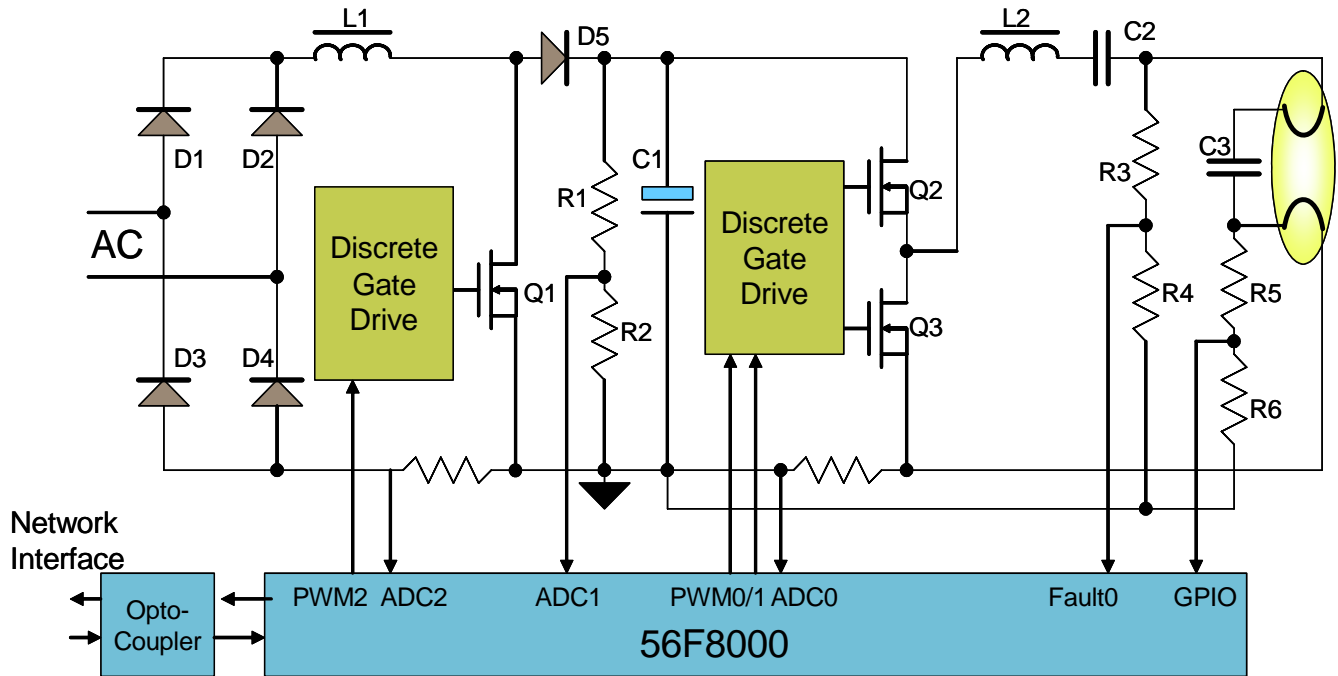

Figure 6. Digital Dimmable Light Ballast

Using a 56F8000 device, new features and performance in lighting can be achieved through intelligent digital control.

## 2.4 Low-Cost Sensorless 3-Phase Motor Control

Electric motors are present in many products that consumers and businesses use every day, including washing machines, air conditioners, refrigerators, garage door openers, pool pumps, tools, and many other products. Businesses use motors in factory automation and equipment. While there are many different types of motors and many different methods for their control, the greatest trend has been toward 3-phase motors. These include the Alternating Current Induction Machine (ACIM), Brushless Direct Current (BLDC) motors, and Permanent Magnet Synchronous Motors (PMSM). Among 3-phase motors' and motor control's significant benefits over other techniques are true variable speed, efficiency, cost, and reliability. With a 56F8000 device, more applications are enabled to the most advanced 3-phase motor control techniques which had previously been cost prohibitive.

Using a 56800E product, motor control can be performed via the software running on the processor with a common hardware platform for all motor types. Figure 7 shows the hardware block diagram for a system that can support ACIM, PMSM, or BLDC motors. The processor is running the control software and, through the PWM output, controls the high-power voltage and current waveforms that are generated in the integrated power module and drive the motor. The unit is attached to 120 V or 220 V AC power, converted by the system to a DC signal. This DC signal is gated via the integrated power module under the control of the device's PWM to produce three separate AC power signals that are offset in phase from one another. In this system, the controller also performs an active Power Factor Correction (PFC) on the rectified AC signal.

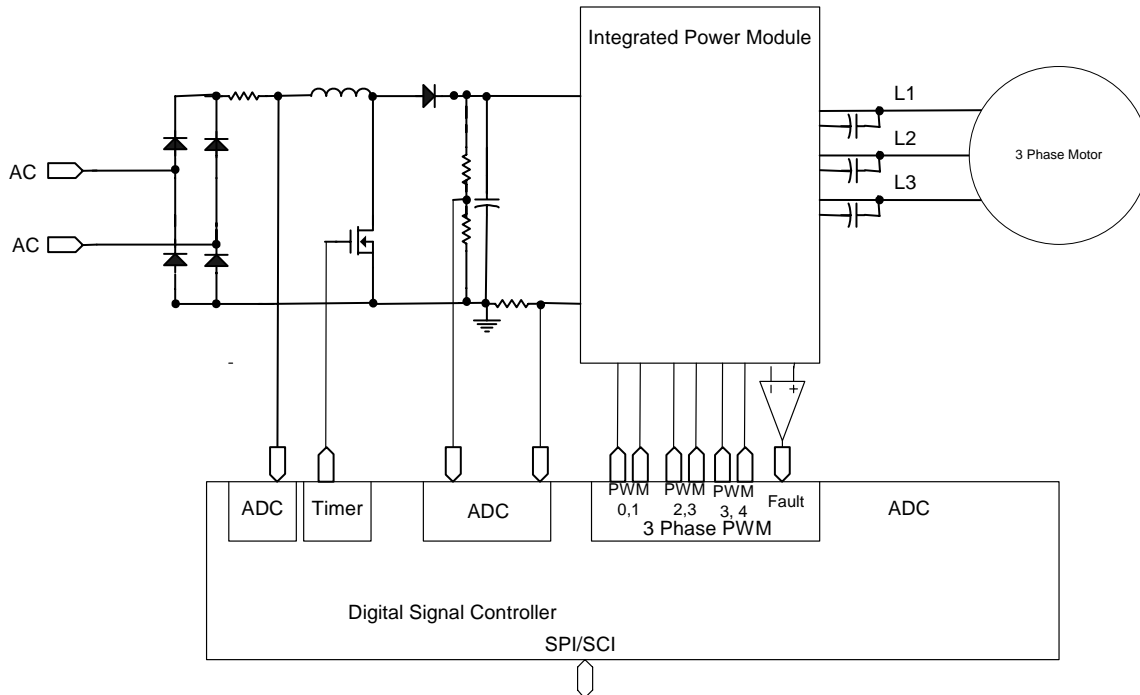

**Figure 7. Low-Cost 3-Phase Motor Control Hardware**

This system is called sensorless because it requires no position or speed sensors to operate. Instead, the DCBus voltage and the currents going into each winding of the motor are converted to a digital value by the ADC and used to determine the speed and position of the motor shaft via software. The following sections explain how the system software is implemented to drive the different motor types.

### 2.4.1 Low-Cost Sensorless Field Oriented ACIM Motor Control

The introduction of the 56F8000 product has revolutionized control of ACIM motors and, specifically, the area of sensorless Field Oriented Control (FOC) techniques for cost sensitive applications. With the 56F8000, ACIM motor control techniques that have traditionally been limited to more costly systems can now be applied to a much broader range of consumer applications, such as washing machines, and general industrial applications, such as lifts and conveyors. The benefits of using sensorless FOC techniques over more traditional motor control techniques include:

- Energy savings
- Quieter operation
- Improved EMI performance
- System cost savings
- Enhanced torque control
- Enhanced reliability

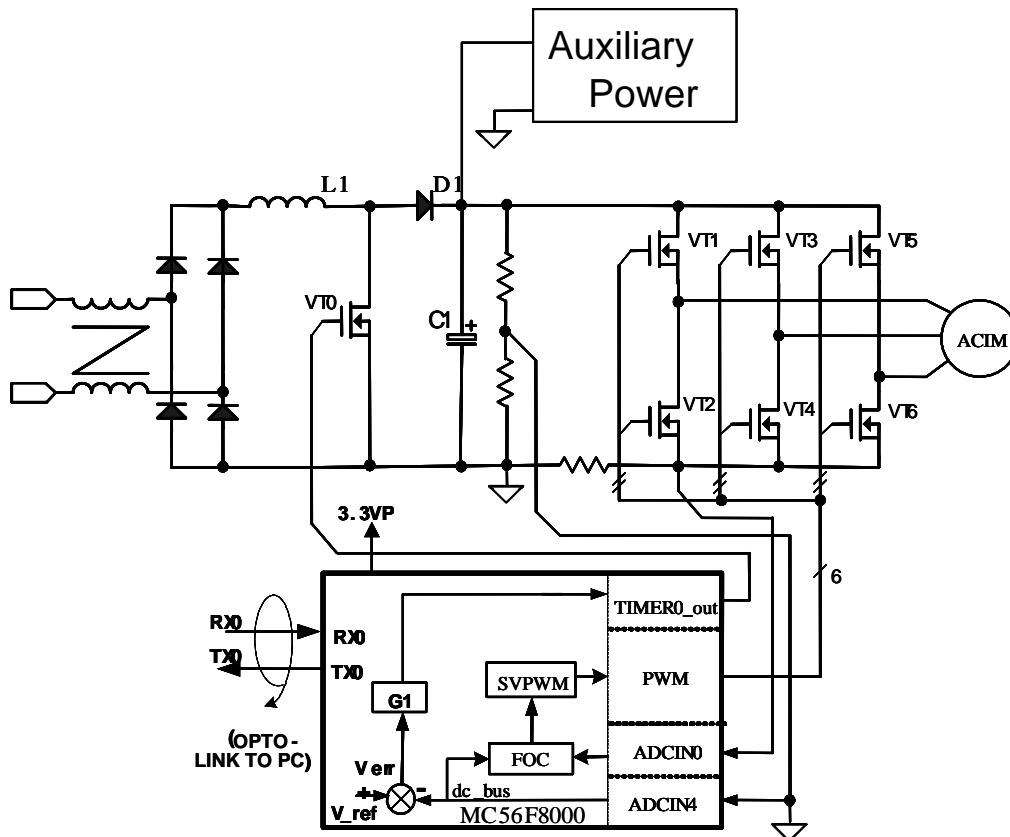

**Figure 8. Functional Block Diagram for a Low-Cost, Sensorless FOC ACIM System**

The system shown in [Figure 8](#) performs AC-to-DC voltage rectification as well as the motor control function. The AC-to-DC power conversion is controlled digitally by the 56F8000 device, enabling it to perform active power factor correction. The DC voltage powers a 3-phase power stage, or inverter stage. This circuitry provides power to the ACIM motor and is controlled directly by the 56F8000 controller.

The method by which the power stage is controlled is called the motor control algorithm. In this system, the motor control algorithm is implemented digitally via firmware running on the processor and is sensorless field oriented control. The speed at which the motor is operating is instead determined by the currents that are flowing in motor windings, rather than by speed or position sensors.

Field oriented control, also referred to as vector control, is a method by which induced currents in the rotor are modified more or less instantaneously by modifying stator currents in a step fashion. The benefits of using FOC is that torque can be controlled very quickly, providing a high dynamic operating range.

The ACIM motor has three terminals and is a balanced 3-phase circuit connected in a traditional Wye pattern. The inputs to the motor are characterized as three sinusoids that are 120 degrees phase shifted from one another. The three sinusoids are generated by the Pulse Width Modulation (PWM) outputs driving the power stage transistors. These transistors are turned on and off and act as switches controlled by the digital PWM signals. The transistors and PWM signals are operated as complementary pairs, each associated with a specific leg of the motor circuit.

The ACIM motor is simple, low cost, reliable, and efficient. In an ACIM motor, the rotor is electrically isolated from the rest of the system. The stator, which is fed by the 3-phase input, creates a rotating

magnetic field, which induces a current in the rotor. This current in turn creates an opposing magnetic force to the rotating magnetic field, in effect causing the rotor to be dragged along by the rotating magnetic field of the stator. The rotor is always operating at a rotational velocity, or RPM, less than the rotational velocity of the rotating stator field. Without this slip speed, no current would be induced in the rotor, since the rotor would be stationary in respect to the rotating stator field.

In a variable speed application, a traditional system might use a universal, DC, or two-speed ACIM motor. This design uses a 3-phase ACIM motor, which is less expensive, lighter, more compact, and more reliable than in a traditional system because the speed is controlled digitally via software running in the chip and not through varying the number of poles in the ACIM motor, or by having a more complex universal or DC motor. The physical motor itself is simplified, while greatly increasing variable speed capability, so it is infinitely variable; using the FOC technique, the torque response is excellent.

There are obviously physical limits to a motor's speed or the torque it can provide. There are three regions of operation, constant torque; constant power; and high speed motoring, for an ACIM motor. These regions are a result of the physical limits of the motor, such as maximum stator current and maximum magnetic flux. This design takes advantage of these different regions to maximize the performance of the system by modifying how the processor's software controls the motor. At low speeds, the software runs the motor in the constant torque region and optimizes the operation by using FOC vector control. For higher-speed operation, the motor control software operates the motor in the constant power region by lowering the provided torque using a field weakening technique. The ability to vary the motor control method under software control yields improved system performance from a lower-cost ACIM motor and mechanical system.

### 2.4.2 Low-Cost Sensorless Vector Control PMSM Motor Control

Although induction motors are used in a variety of industrial applications and white goods because of their durability, quiet operation and low cost, they are not ideal for some fractional horsepower motor applications. High-efficiency Permanent Magnet AC Synchronous Motors (PMSMs) are an excellent choice for these types of applications. New PM motor technology replaces a distributed-winding interior permanent magnet motor with a concentrated-winding interior permanent magnet motor. This replacement makes the new PMSM motor even cheaper and more efficient than a conventional PMSM motor. Use of the high-efficiency PMSM motor plus variable speed control can be effective in energy conservation and size reductions in fractional horsepower applications, especially for white goods such as air-conditioners and refrigerators. For low-end applications using a PMSM motor, such as compressors, a sensorless control method that provides variable speed control for the PMSM motor without using rotor position sensors eases the concerns of cost and reliability in the application environment. In some compressor designs, the motor is encased with coolant material in a sealed unit, eliminating the sensor and sensor wires that must pierce the seal, making the mechanical design simpler and more reliable.



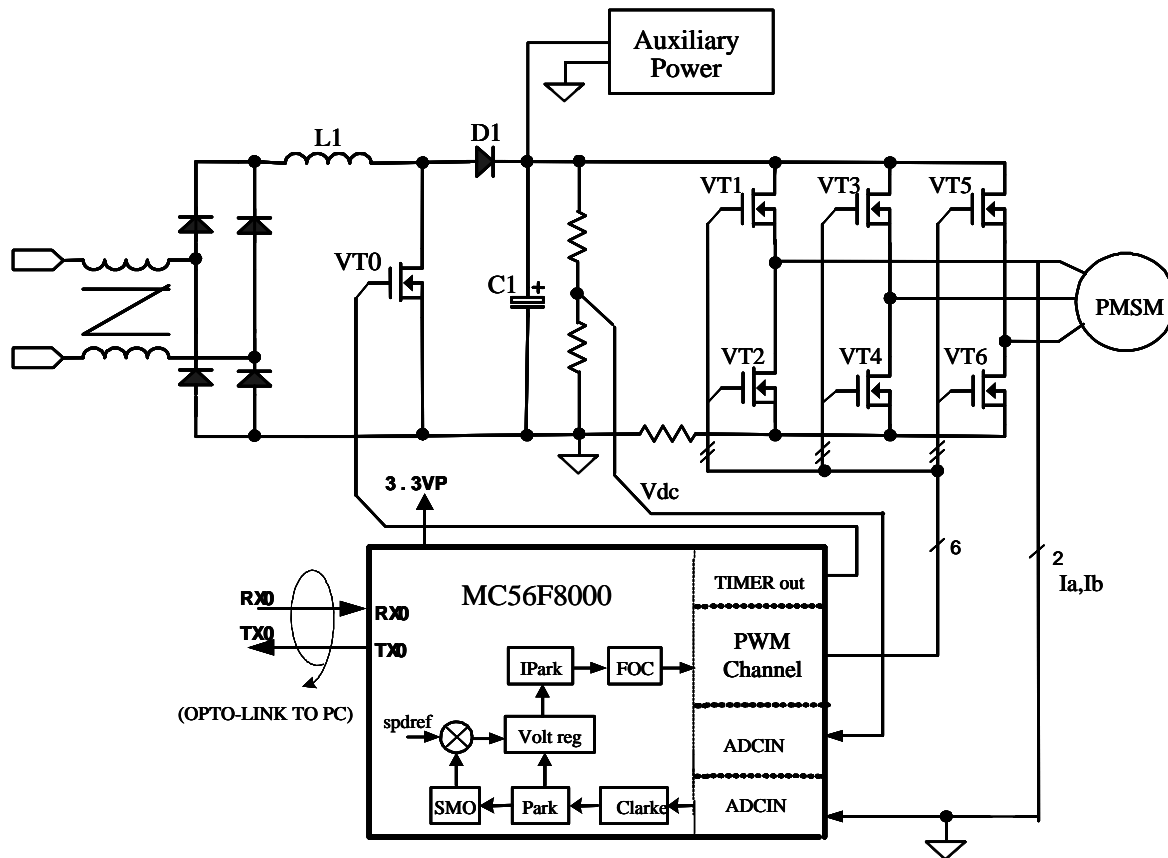

**Figure 9. Functional Block Diagram of a Low-Cost Sensorless Vector Control PMSM System**

Permanent magnet synchronous motors are assembled with a magnetic rotor and wound stator construction. The wound stators can rapidly dissipate heat to the motor housing and environment, in contrast to brush motors, which trap the heat under a non-conductive air gap. This results in greater efficiency and power density for the PMSM design and provides high torque-to-inertia ratios. PMSM motors generate magnetic flux using permanent magnets in the rotors, which are driven by the stators, applying a synchronous rotational field. On the other hand, the flux that is applied by the stators (the armature-reaction flux) generates torque most effectively when it is perpendicular to flux generated by the rotors. The Field Oriented Control control method is used to maintain a near-perpendicular position between stator flux and rotor flux. This system is a sensorless implementation, so no position sensors are used.

Among the advantages offered by this system over traditional implementations are:

- Ability to control motors over a wide range of speeds
- Precise speed regulation without additional cost
- Capable of rapid acceleration and deceleration
- Starting torque and dynamic response equal to or better than conventional DC drives
- Ability to operate several brushless drives from a common DCBus
- No mechanical wear or conductive brush dust

Using a PMSM motor and sensorless FOC control that provides variable speed and very low torque ripple at a low cost offers significant advantages. In products such as compressors, used for refrigerators, air conditioners, and other cooling or cold appliances, these advantages include increased energy efficiency, quieter operation, and improved reliability.

### 2.4.3 Low-Cost Sensorless BLDC Motor Control

Brushless DC (BLDC) systems combine the positive attributes of AC and DC systems. In contrast to a brush DC motor, a motor conventionally used in a BLDC system is a type of permanent magnet AC synchronous motor with a trapezoidal back-EMF waveform shape; electronic commutation replaces the DC motor’s mechanical brushes. Although this control method will generate torque ripple during phase commutation, it can also satisfy most applications in which the control target is rotor speed. Possible applications include appliances, air movement products (fans), toys, lower-power industrial applications, and small pumps.

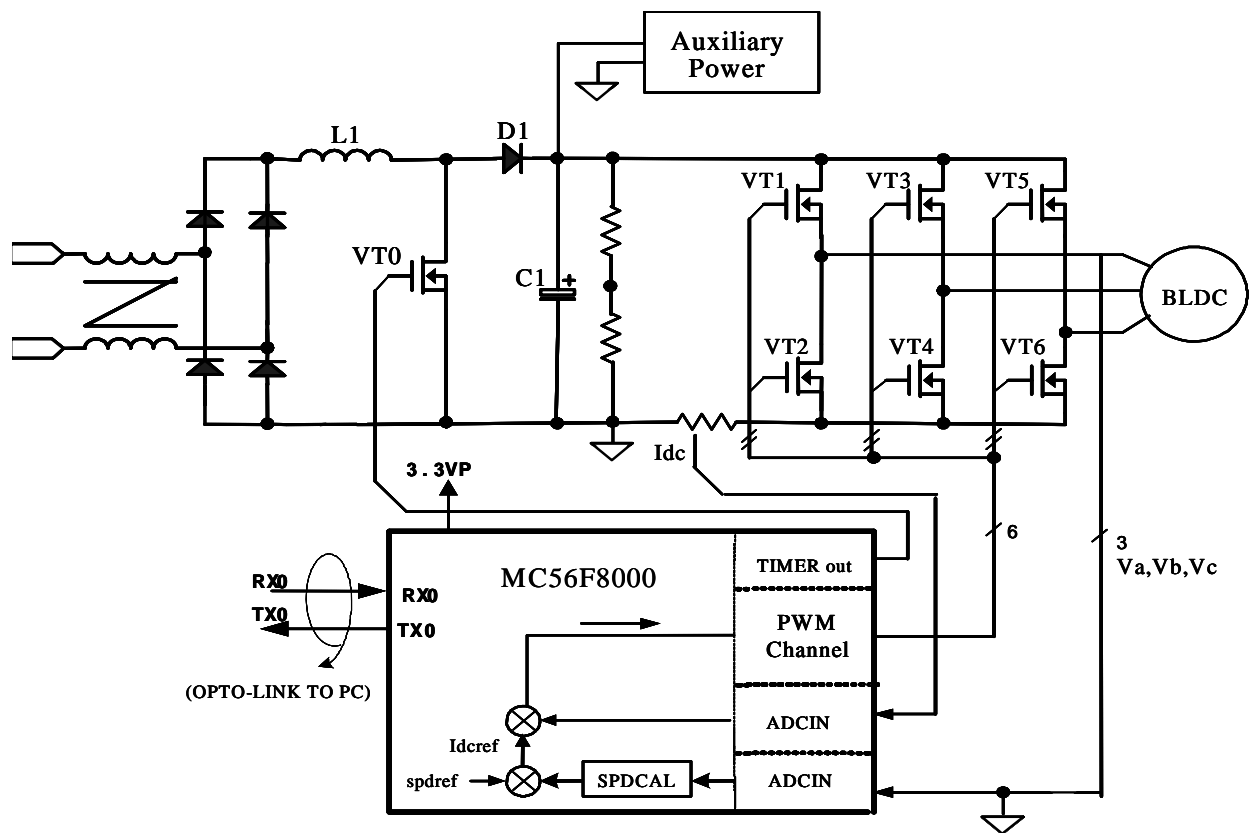

Figure 10. Low Cost Sensorless BLDC Motor Control Functional Block Diagram

In a BLDC motor, the stator has windings that must be excited in a rotating fashion, called commutation. The commutation controls the speed and torque of the motor shaft. The information of back-EMF zero crossing is used to determine the rotor position for proper commutation and to determine which power transistors to turn on to obtain maximum motor torque. The cheapest and the most reliable method for sampling the information of back-EMF zero crossing is to use a resistor network that samples the back-EMF signal and feeds it into ADC inputs, as shown in Figure 10.

This system eliminates the position sensors typically required for BLDC motor control and provides true variable speed control at low cost, with low noise, and high reliability.

## 2.5 Wireless Battery-Powered Sensor Application

A 56F8000 device offers a wide variety of power-saving modes that can battery power the chip and create a wireless system with Freescale RF modem chips. The wireless chips are intended for inexpensive systems and have a range that enables communication throughout an area the size of a typical home. This allows applications for industrial-sensing end products, such as building management or personal medical devices. Non-battery-powered applications can also benefit from the wireless connectivity capability, including the dimmable ballast control discussed in [Section 2.3, “Digital Dimmable Lighting Ballast.”](#) A building with standard power connections for fluorescent lighting does not have to be rewired to include the dimming feature because the required control bus can be performed using the wireless link.

[Figure 11](#) shows a system enabled with Freescale’s MC13191 RF modem chips and low-g acceleration sensors, such as the MMA6260Q.

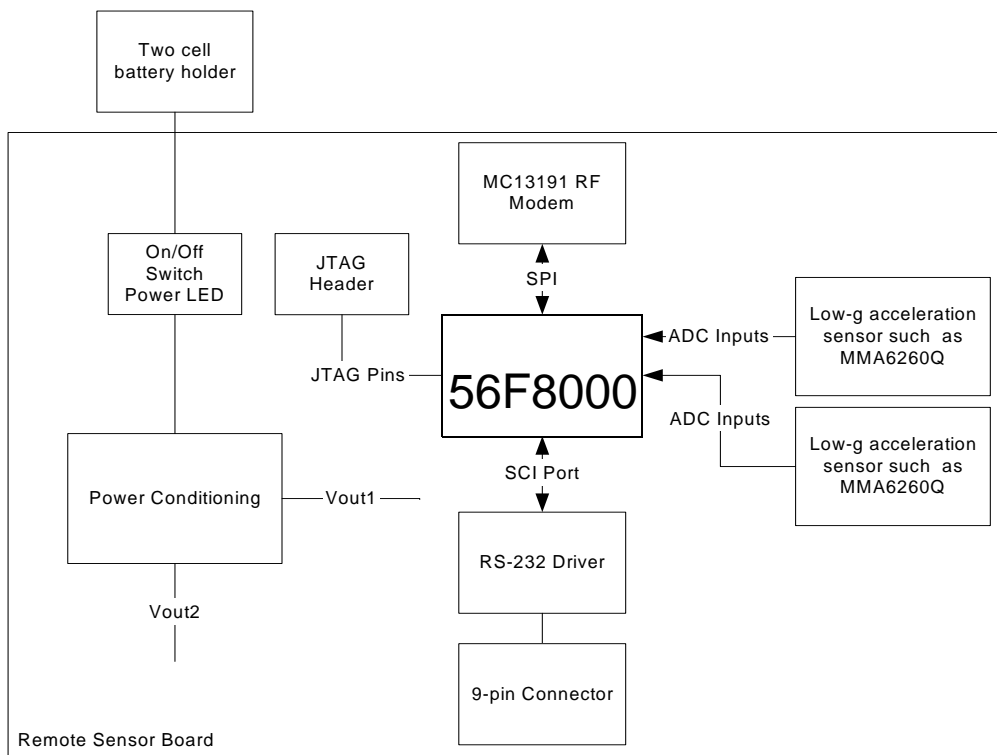

**Figure 11. Block Diagram of Battery-Powered Wireless Sensor Hardware**

This system uses the capability of a 56F8000 device to very precisely control the power that it uses and to go into a variety of lower power modes. The 56F8000 devices can turn the clocks to each peripheral on and off, can go into Stop and Wait modes for power conservation, and set up the ADC to automatically go from a low-power standby to active state only when conversions must be done. The 56F8000 is a fully static design that enables clocks to be completely shut off to the part. The internal clock generation module can be used to adjust the exact power versus processor performance that is best suited for the application.

## Conclusion

Additionally, the internal relaxation oscillator can be placed in a low-power, low-frequency mode for power savings.

As shown, a 56F8000 device has the features and performance to operate in battery-powered applications and, when used in conjunction with the RF modem chips from Freescale, it can stay connected wirelessly.

## 3 Conclusion

With the introduction of the expanded 56F8000 series of controllers, Freescale has provided processors with a new level of price / performance, expanded high-performance peripherals, and integration. The expanded 56F8000 series provides Freescale's current 8/16-bit MCU and 56800/E customers with an excellent path to increased performance, features, and low cost. The enhanced performance of the peripherals, such as the ADC, PWM, Timer, QSCI, QSPI and the inclusion of new peripherals, such as the DAC, analog comparator and I<sup>2</sup>C, coupled with the low cost and small size of the expanded 56F8000 series devices, enable a developer to expand his horizons with new product possibilities in digital power conversion, low-cost 3-phase motor control, battery-powered applications, and analog control replacement. This white paper has shown only a few of the applications made possible and practical using the new price / performance-leading and feature-filled expanded 56F8000 processors from Freescale.

THIS PAGE IS INTENTIONALLY BLANK

## How to Reach Us:

### Home Page:

[www.freescale.com](http://www.freescale.com)

### E-mail:

[support@freescale.com](mailto:support@freescale.com)

### USA/Europe or Locations Not Listed:

Freescale Semiconductor  
Technical Information Center, CH370  
1300 N. Alma School Road  
Chandler, Arizona 85224  
+1-800-521-6274 or +1-480-768-2130  
[support@freescale.com](mailto:support@freescale.com)

### Europe, Middle East, and Africa:

Freescale Halbleiter Deutschland GmbH  
Technical Information Center  
Schatzbogen 7  
81829 Muenchen, Germany  
+44 1296 380 456 (English)  
+46 8 52200080 (English)  
+49 89 92103 559 (German)  
+33 1 69 35 48 48 (French)  
[support@freescale.com](mailto:support@freescale.com)

### Japan:

Freescale Semiconductor Japan Ltd.  
Headquarters  
ARCO Tower 15F  
1-8-1, Shimo-Meguro, Meguro-ku,  
Tokyo 153-0064  
Japan  
0120 191014 or +81 3 5437 9125  
[support.japan@freescale.com](mailto:support.japan@freescale.com)

### Asia/Pacific:

Freescale Semiconductor Hong Kong Ltd.  
Technical Information Center  
2 Dai King Street  
Tai Po Industrial Estate  
Tai Po, N.T., Hong Kong  
+800 2666 8080  
[support.asia@freescale.com](mailto:support.asia@freescale.com)

### For Literature Requests Only:

Freescale Semiconductor Literature Distribution Center  
P.O. Box 5405  
Denver, Colorado 80217  
1-800-441-2447 or 303-675-2140  
Fax: 303-675-2150  
[LDCForFreescaleSemiconductor@hibbertgroup.com](mailto:LDCForFreescaleSemiconductor@hibbertgroup.com)

Document Number: 56F80XXEWP  
Rev. 0  
09/2006

Information in this document is provided solely to enable system and software implementers to use Freescale Semiconductor products. There are no express or implied copyright licenses granted hereunder to design or fabricate any integrated circuits or integrated circuits based on the information in this document.

Freescale Semiconductor reserves the right to make changes without further notice to any products herein. Freescale Semiconductor makes no warranty, representation or guarantee regarding the suitability of its products for any particular purpose, nor does Freescale Semiconductor assume any liability arising out of the application or use of any product or circuit, and specifically disclaims any and all liability, including without limitation consequential or incidental damages. "Typical" parameters that may be provided in Freescale Semiconductor data sheets and/or specifications can and do vary in different applications and actual performance may vary over time. All operating parameters, including "Typicals", must be validated for each customer application by customer's technical experts. Freescale Semiconductor does not convey any license under its patent rights nor the rights of others. Freescale Semiconductor products are not designed, intended, or authorized for use as components in systems intended for surgical implant into the body, or other applications intended to support or sustain life, or for any other application in which the failure of the Freescale Semiconductor product could create a situation where personal injury or death may occur. Should Buyer purchase or use Freescale Semiconductor products for any such unintended or unauthorized application, Buyer shall indemnify and hold Freescale Semiconductor and its officers, employees, subsidiaries, affiliates, and distributors harmless against all claims, costs, damages, and expenses, and reasonable attorney fees arising out of, directly or indirectly, any claim of personal injury or death associated with such unintended or unauthorized use, even if such claim alleges that Freescale Semiconductor was negligent regarding the design or manufacture of the part.

Freescale™ and the Freescale logo are trademarks of Freescale Semiconductor, Inc. All other product or service names are the property of their respective owners.

© Freescale Semiconductor, Inc. 2006. All rights reserved.

RoHS-compliant and/or Pb-free versions of Freescale products have the functionality and electrical characteristics as their non-RoHS-compliant and/or non-Pb-free counterparts. For further information, see <http://www.freescale.com> or contact your Freescale sales representative.

For information on Freescale's Environmental Products program, go to <http://www.freescale.com/epp>.