

AN4006

Digital Capacitive Discharge Ignition System using HC05/HC08 8-Bit Microcontrollers

By Kenny Lam
Market Development
Transportation Systems Group
Asia Pacific Region

This application note describes the basic principle of the digital capacitive discharge Ignition (CDI) system for two-wheelers, and outlines a solution using Motorola's low-cost MC68HC705P6A microcontroller unit.

Introduction

The two-wheelers industry: scooters, motorcycles, and mopeds, commonly use an engine ignition system based on the capacitive discharge method, known as *Capacitive Discharge Ignition (CDI)*. This ignition system makes use of the energy transferred from a magneto to a storage capacitor, and then released as a high voltage pulse via a step-up transformer to a spark plug to ignite the fuel mixture inside the cylinder. Using this method saves having to

Ignition System

An ignition system functions to provide a high voltage spark in each of the engine's cylinders to ignite the air-fuel mixture. This high voltage spark must be distributed — the ignition timing — to each of the cylinders at just the right moment for the power stroke.

Traditionally, the CDI timing for the single-cylinder two-wheeler is fixed, known as *fixed-time CDI*. The timing of the high voltage spark is fixed on every piston cycle. Because the time from ignition to combustion in the cylinder is not instantaneous, the spark is timed to occur before the end of the compression stroke in order for combustion to be completed in time to drive the piston downwards on the power stroke.

Early Ignition

This fixed timing of the spark has drawbacks. During engine idling speeds, the ignition will occur too early during the compression stroke, combustion will be completed before the piston reaches the top-dead-center position. The piston tries to complete its compression stroke against the high pressure, resulting in engine stall or kick-back when being started if the flywheel momentum cannot overcome the pressure. This is noticeable with an audible detonating knock. This untimely detonation, together with overheating may cause damages to the piston.

Late Ignition

At the other end, during high engine speeds, the ignition will occur too late during the compression stroke, combustion will not be completed until the piston is some way along its power stroke. The pressure that propels the piston will be reduced, resulting in a loss of power.

Advantages of Digital CDI

With a variable timing CDI solution, the speed of the engine is monitored to provide a optimum timing for the spark. At idling speeds, the ignition can be timed to occur quite late in the compression stroke since there is enough time for combustion to be completed as the piston starts its power stroke. At high speeds, ignition must occur earlier in the compression stroke.

A variable timing CDI system can be implemented by mechanical or electronic methods. The electronic solution make uses of the microcontroller (MCU) for monitoring engine speed and providing the accurate timing for the spark. Another advantage of using the MCU is that the ignition spark can be made to occur anytime for a particular engine speed. Therefore the ignition angle can be fully customized for different engine designs.

Having a perfect ignition timing will increase engine efficiency, save energy, and less pollution.

Basic Components of Two-Wheelers for CDI

CDI is also called *thyristor ignition system*. A CDI system with induction type pulse generator contains a trigger box, a charging device, and a pulse shaping circuit and ignition transformer. The main components are shown below.

Freescale Semiconductor, Inc.

Magneto

A small two- or four-stroke single or dual cylinder engine has a flywheel, incorporating permanent magnets. The rotor, consisting of a copper coil, produces an AC voltage between 100V to 400V, is proportional to the speed of the engine. After rectification, this high DC voltage is applied to the capacitor portion. The magneto is also known as the *alternator*, see figure 1.

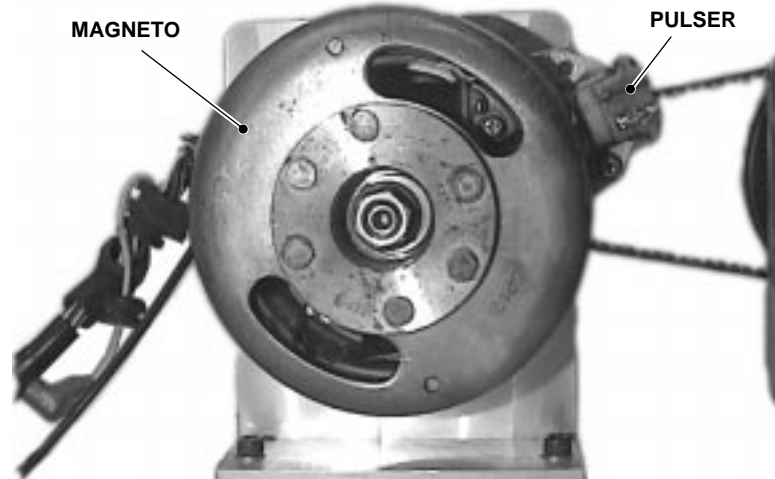

Figure 1. Magneto/Pulser Assembly

Pulser

The pulser is a small coil mounted on the magneto, that generates an alternating pulse while the engine rotates. These pulses are induced from the two poles (N and S) of the magnetic plate that is mounted on the framework of the magneto while it rotates and passes the pulser coil. The N and S poles induces a positive pulse followed by a negative pulse that is typically 25 mechanical degrees apart. The 25 degrees is fixed by the length of the magnetic plate. The peak of the negative pulse is taken as the reference point, the top-dead-center of the piston. Therefore, the positive pulse leads the negative pulse by 25 mechanical degrees.

Spark Plug

The spark plug is the final element in the ignition chain. High engine efficiency and complete gas combustion are linked to a good quality spark. Generally, an estimated minimum of 20 milli-joules is necessary at the spark plug to produce a sufficient spark.



Figure 3. Spark Plug

Digital CDI Module

Figure 4 is a block diagram showing a typical digital CDI module. At the heart of the timing control circuit is the MCU; monitoring the engine speed and calculating the timing for the spark.

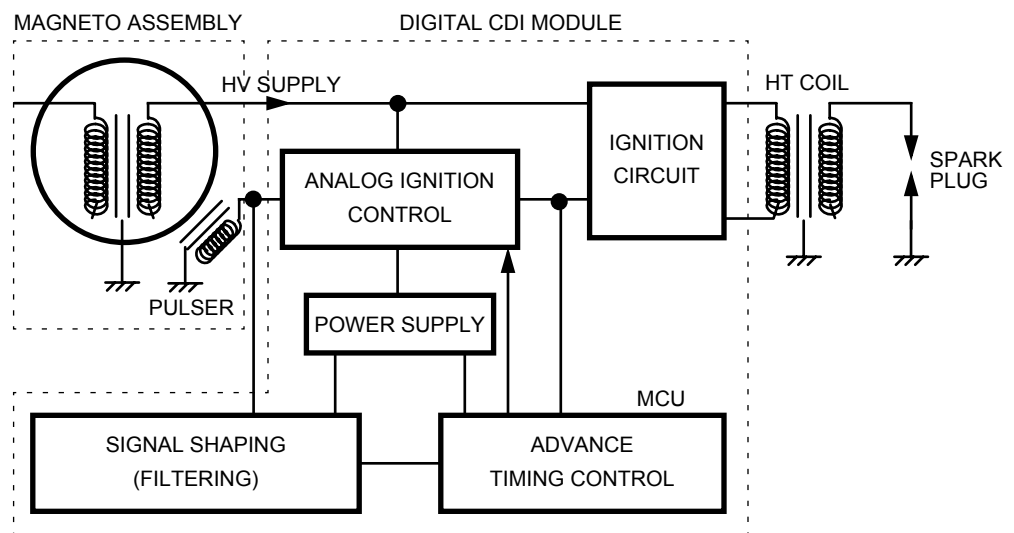

Figure 4. Typical Digital CDI System Block Diagram

The digital CDI module is divided into the following control blocks, and the following paragraphs describe the function of each block:

- Analog ignition control
- Power supply
- Signal shaping (filtering)
- Advanced timing control (MCU)
- Ignition circuit block

Analog Ignition Control

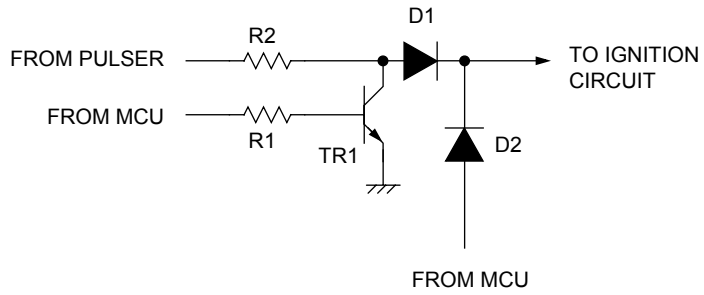

Figure 5. Analog Ignition Control

This *Analog Ignition Control* is designed for the engine start-up stage, since the 5V DC supply to the MCU may not be ready during engine cold starts. During this start-up stage, the ignition timing follows the signal of the pulser. In figure 5, R2 is to limit the current to the *Ignition Circuit*. Diodes D1 and D2 are to prevent the interference between MCU and *Analog Ignition Control*.

The MCU will turn off the *Analog Ignition Control* by turning on TR1 once the MCU is ready. Then, the *Ignition Circuit* will be directly controlled by MCU itself.

Power Supply

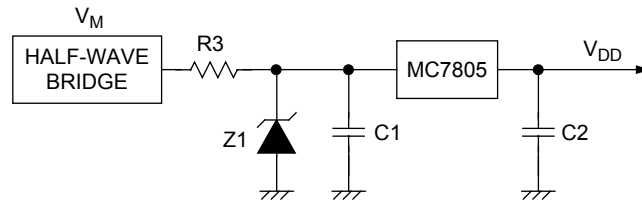

Figure 6. DC Power Supply

The magneto provides, after rectification, a regulated 5V to supply the entire module for variable timing ignition control. In figure 6, the half-wave bridge is to supply the negative phase from the magneto to the digital CDI board. The resistor, R3, is the current limiter. The zener, Z1, which absorbs the excessive

**Signal Shaping
(Filtering)**

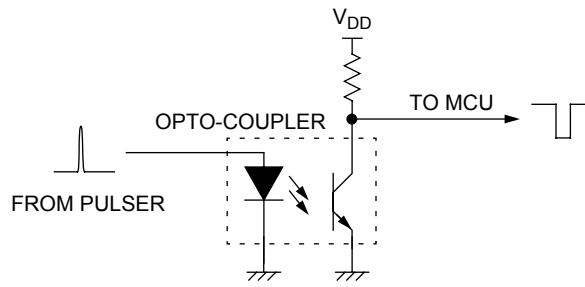

Figure 7. Pulse Shaping

In figure 7, the opto-coupler performs filtering of spikes occurring on the sensor signal. It also converts the analog pulses into digital pulses for the MCU. The period of the pulses determined the RPM of the engine.

**Advanced
Timing Control
(MCU)**

At the heart of the *advance timing control* block is the MCU. This MCU takes the reference pulses generated by the pulser and calculates the firing angle based on the engine speed.

Ignition Circuit

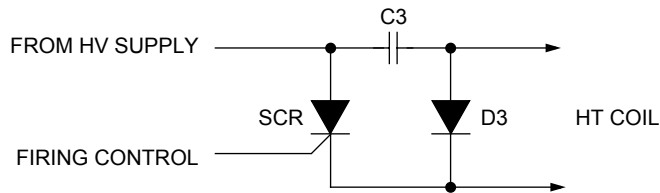

Figure 8. Advance Timing Control

In figure 8, the diode, D3 conducts the forward current for charging up the capacitor. When the spark is required, a current from the *Advanced Timing Control* is injected into the SCR gate, firing it. The SCR firing initiates the discharge of the capacitor, C3, which generates a current and transfers it to the primary winding of the ignition coil. The SCR conducts during the first part of the current cycle until the capacitor voltage reaches 0V. The secondary coil induces a high voltage (typically 14kV) while the current passes through the primary coil. The spark plug then generates the spark from the high voltage. Typically, C3 with a value somewhere between 0.47 μ F and 2 μ F stores the charge from the magneto supply, which provides, after rectification, a positive voltage.

Digital CDI Operation

The typical operation of the digital CDI module can be divided into three modes:

1. Low engine speeds: The ignition spark is applied on detection of the negative sensor pulse (zero degrees; piston at top-dead-center).
2. High engine speeds: The ignition spark is applied on detection of the positive sensor pulse (25 degree advance).
3. Intermediate engine speeds: Between low and high speeds, the ignition advance angle is directly proportional to the engine speed.

Figure 9 illustrates the ignition advance angle for different engine speeds.

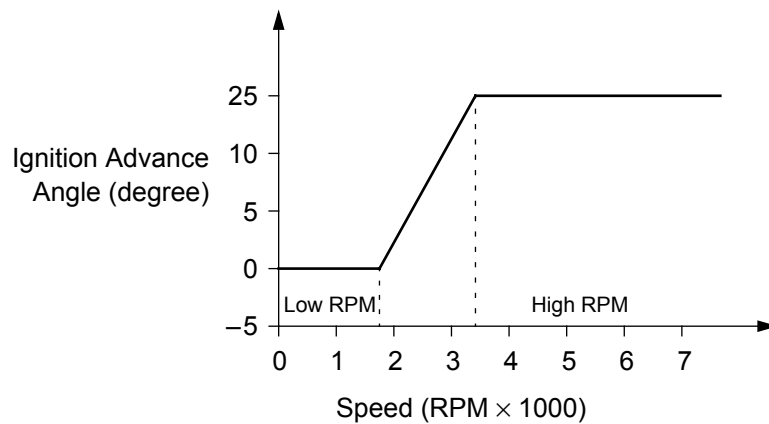
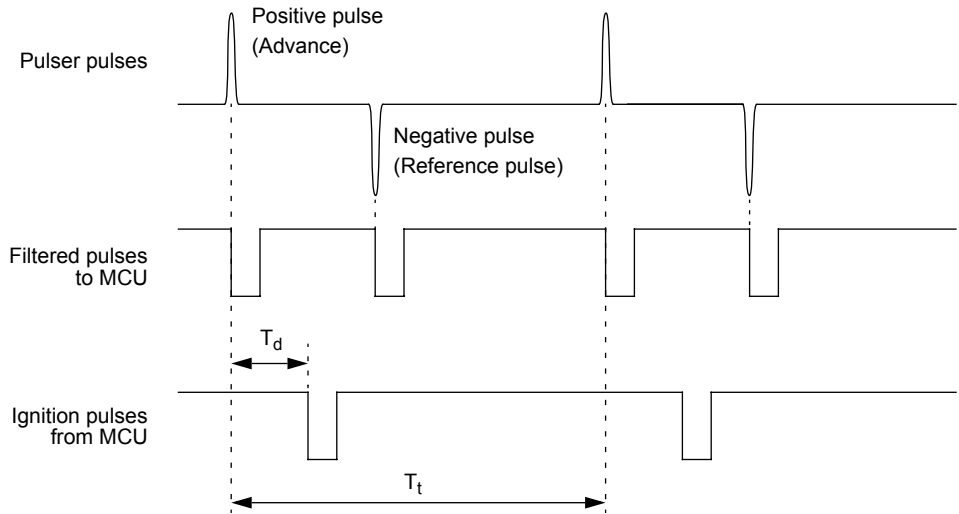

Figure 9. Ignition Advance Characteristics

Principle of Operation

The pulses from the pulser are captured by the MCU via the isolation circuit (the pulse shaping circuit). From the pulses the MCU uses its 16-timer to count



T_d = Delay value calculated with respect to positive pulse (Advance)

T_t = Time period

$$\text{Engine RPM} = \frac{1}{T_t \text{ (in sec)}} \times 60$$

Figure 10. Ignition Advance Waveforms

Further Information — Digital CDI Reference Design

The digital CDI reference design, using Freescale’s MC68HC705P6A MCU, with circuit schematics, PCB layout, and MCU source code is available from Freescale. Please contact your local Freescale representative for further details.

Information in this document is provided solely to enable system and software implementers to use Freescale Semiconductor products. There are no express or implied copyright licenses granted hereunder to design or fabricate any integrated circuits or integrated circuits based on the information in this document. Freescale Semiconductor reserves the right to make changes without further notice to any products herein. Freescale Semiconductor makes no warranty, representation or guarantee regarding the suitability of its products for any particular purpose, nor does Freescale Semiconductor assume any liability arising out of the application or use of any product or circuit, and specifically disclaims any and all liability, including without limitation consequential or incidental damages. "Typical" parameters which may be provided in Freescale Semiconductor data sheets and/or specifications can and do vary in different applications and actual performance may vary over time. All operating parameters, including "Typicals" must be validated for each customer application by customer's technical experts. Freescale Semiconductor does not convey any license under its patent rights nor the rights of others. Freescale Semiconductor products are not designed, intended, or authorized for use as components in systems intended for surgical implant into the body, or other applications intended to support or sustain life, or for any other application in which the failure of the Freescale Semiconductor product could create a situation where personal injury or death may occur. Should Buyer purchase or use Freescale Semiconductor products for any such unintended or unauthorized application, Buyer shall indemnify and hold Freescale Semiconductor and its officers, employees, subsidiaries, affiliates, and distributors harmless against all claims, costs, damages, and expenses, and reasonable attorney fees arising out of, directly or indirectly, any claim of personal injury or death associated with such unintended or unauthorized use, even if such claim alleges that Freescale Semiconductor was negligent regarding the design or manufacture of the part.