



NewTec battery management system (BMS) reference design

NEWTEC-NTBMS

Last Updated: Jan 19, 2024

The NEWTEC-NTBMS is an e-mobility reference design and complete safety support package for battery management systems (BMS).

Developed in partnership with [NewTec](#), the NEWTEC-NTBMS is intended for device manufacturers with Lithium-ion batteries and suppliers of automotive or industrial applications. It provides a high degree of reliability and safety, targeting BMS up to ASIL C according to ISO 26262.

NEWTEC-NTBMS Safety System-on-Module (SoM) Block Diagram

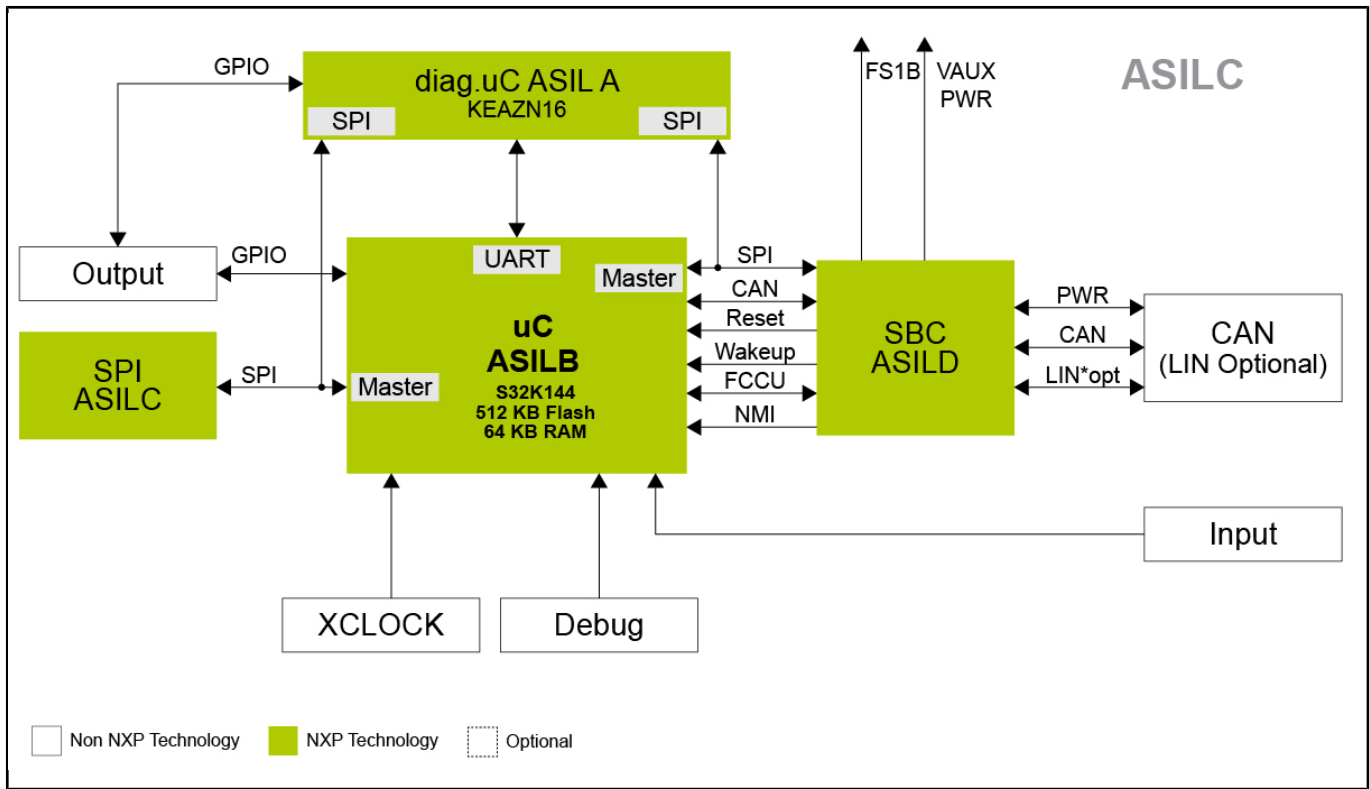

NEWTEC Design Block Diagram

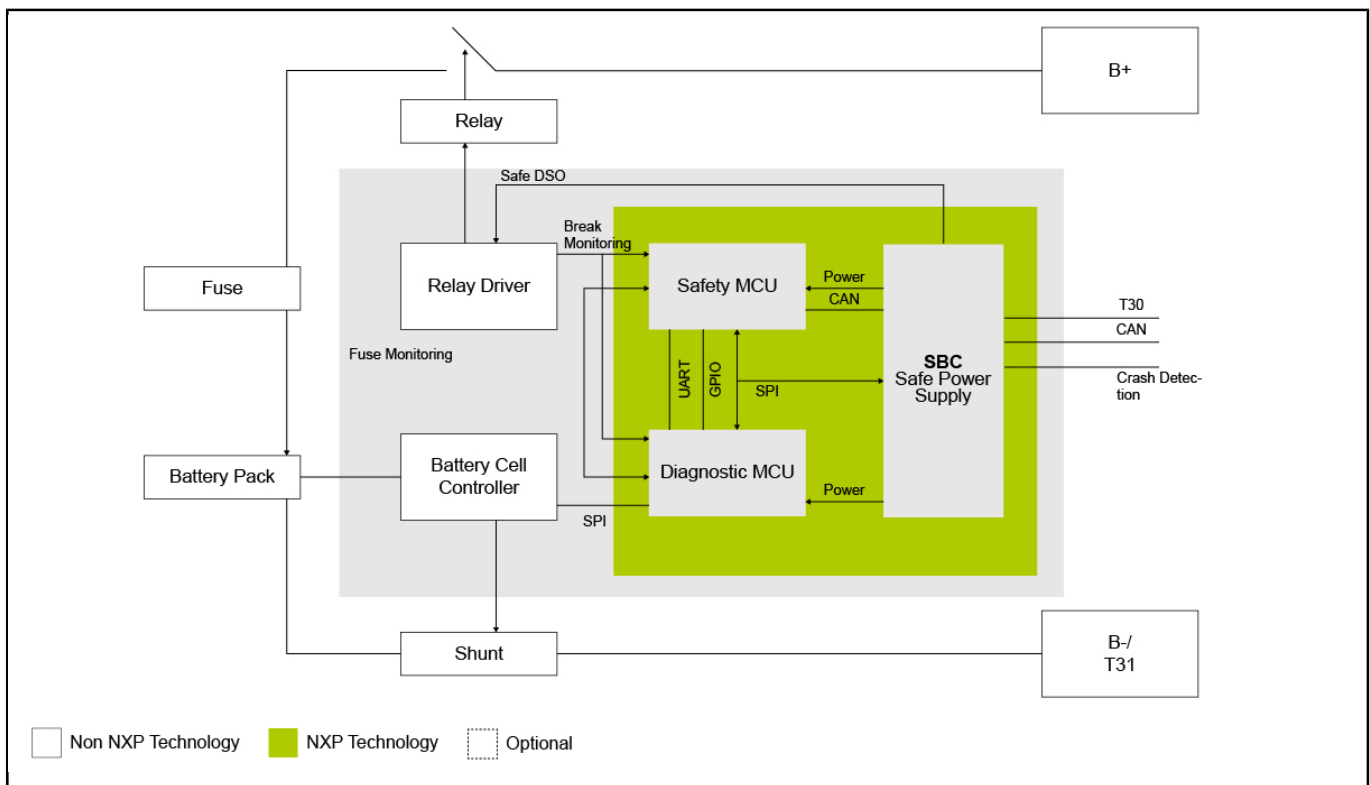

View additional information for [NewTec battery management system \(BMS\) reference design](#).

Note: The information on this document is subject to change without notice.

www.nxp.com

NXP and the NXP logo are trademarks of NXP B.V. All other product or service names are the property of their respective owners. The related technology may be protected by any or all of patents, copyrights, designs and trade secrets. All rights reserved. © 2024 NXP B.V.