



MPC5777C BMS and Engine Control Development Board

MPC5777C-DEVB

Archived

This page contains information on a product that is no longer manufactured (discontinued). Specifications and information herein are available for historical reference only.

Last Updated: May 9, 2024

Not recommended for new designs, please use [MPC577C-DEVB2](#).

The MPC5777C-DEVB is a development board engineered for a range of applications: from traction motors and Battery Management Systems (BMS) to internal combustion engines and transmissions.

Based on the 32-bit Power Architecture® MPC5777C ultra-reliable microcontroller together with the FS65 System Basis Chip (SBC) and the TJA1100 and TJA1145T/FD Ethernet and CAN FD PHY transceivers, the MPC5777C-DEVB facilitates hardware and software development, offering system performance, safety, and security.

MPC5777C-DEVB Block Diagram

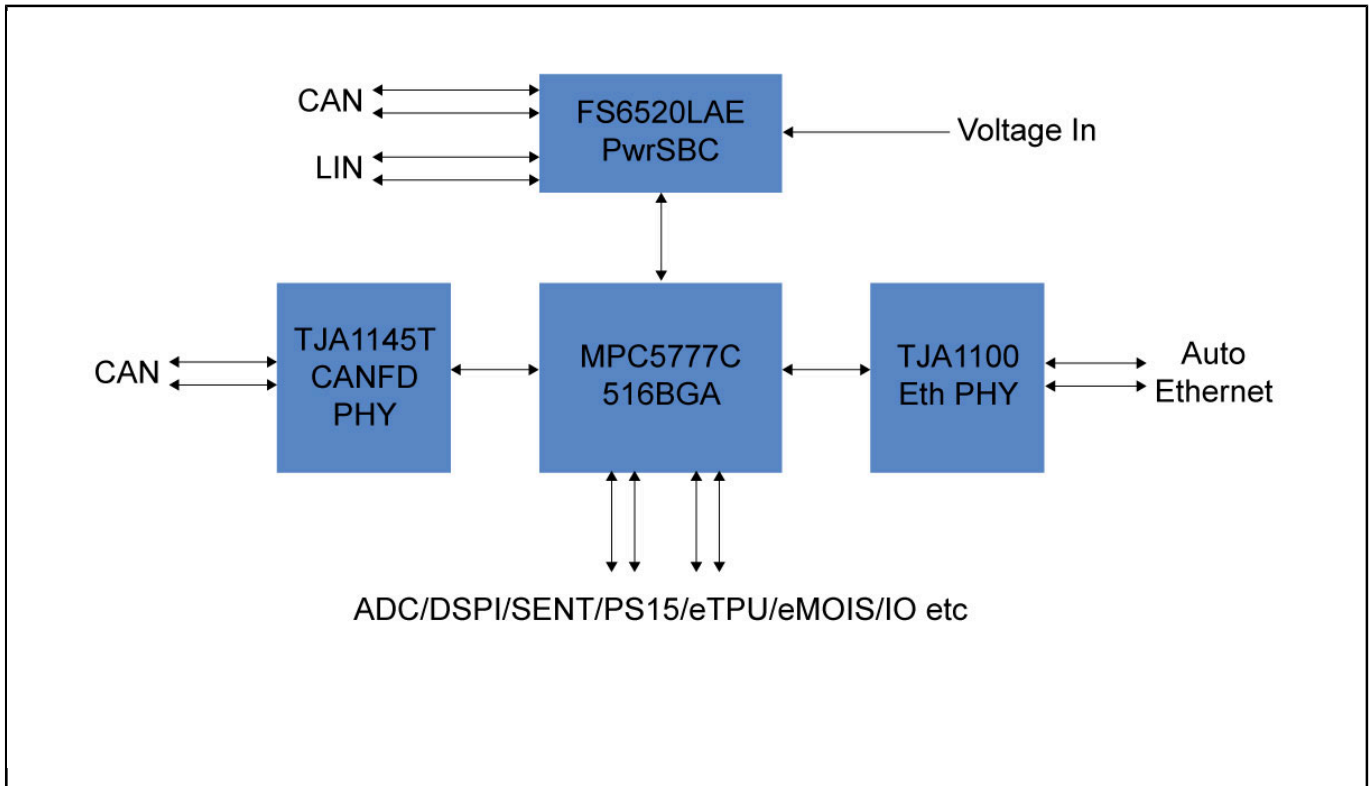

View additional information for [MPC5777C BMS and Engine Control Development Board](#).

Note: The information on this document is subject to change without notice.

www.nxp.com

NXP and the NXP logo are trademarks of NXP B.V. All other product or service names are the property of their respective owners. The related technology may be protected by any or all of patents, copyrights, designs and trade secrets. All rights reserved. © 2024 NXP B.V.