



SOT813-4

plastic thermal enhanced very thin quad flat package; no leads; 72 terminals, 0.5 mm pitch, 10 mm x 10 mm x 0.85 mm body

11 February 2019

Package information

1 Package summary

Terminal position code	Q (quad)
Package type descriptive code	HVQFN72
Package type industry code	HVQFN72
Package style descriptive code	HVQFN (thermal enhanced very thin quad flatpack; no leads)
Package body material type	P (plastic)
JEDEC package outline code	MO-220
Mounting method type	S (surface mount)
Issue date	26-07-2012
Manufacturer package code	SOT813

Table 1. Package summary

Parameter	Min	Nom	Max	Unit
package length	9.9	10	10.1	mm
package width	9.9	10	10.1	mm
seated height	0.8	0.85	1	mm
nominal pitch	-	0.5	-	mm
actual quantity of termination	-	72	-	



plastic thermal enhanced very thin quad flat package; no leads; 72 terminals, 0.5 mm pitch, 10 mm x 10 mm x 0.85 mm body

2 Package outline

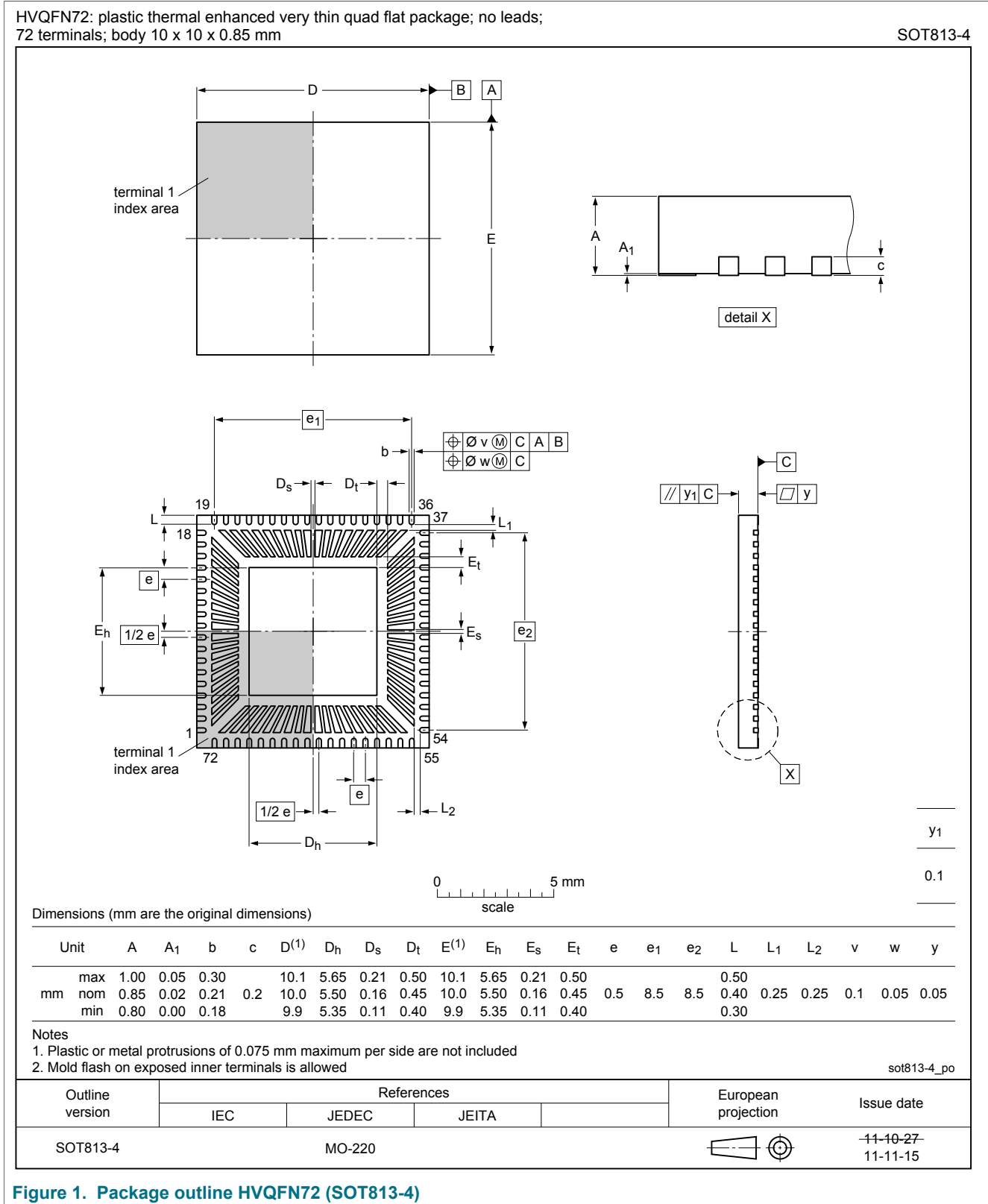

Figure 1. Package outline HVQFN72 (SOT813-4)

plastic thermal enhanced very thin quad flat package; no leads; 72 terminals, 0.5 mm pitch, 10 mm x 10 mm x 0.85 mm body

3 Soldering

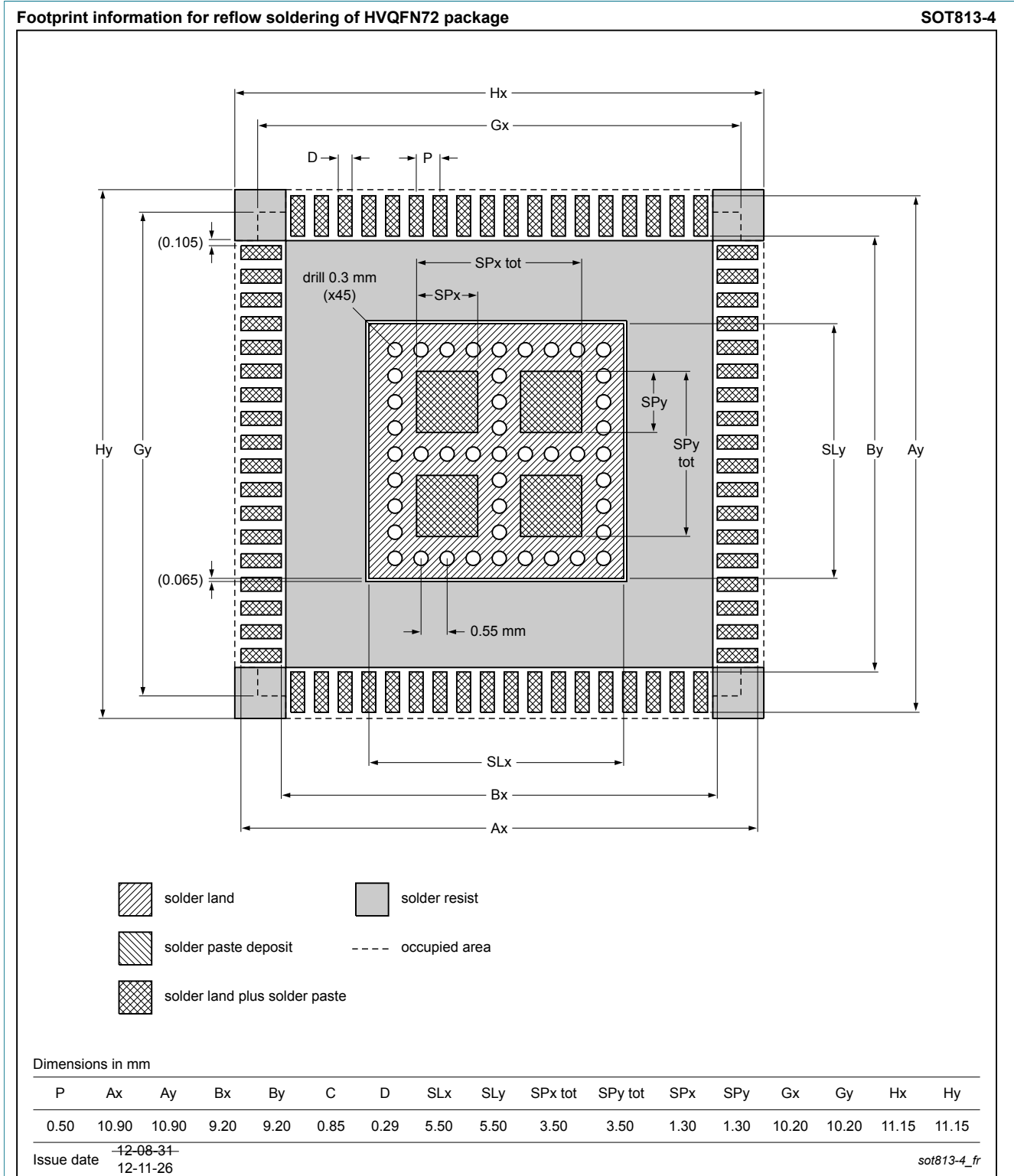

Figure 2. Reflow soldering footprint for HVQFN72 (SOT813-4)

plastic thermal enhanced very thin quad flat package; no leads; 72 terminals, 0.5 mm pitch, 10 mm x 10 mm x 0.85 mm body

4 Legal information

Disclaimers

Limited warranty and liability — Information in this document is believed to be accurate and reliable. However, NXP Semiconductors does not give any representations or warranties, expressed or implied, as to the accuracy or completeness of such information and shall have no liability for the consequences of use of such information. NXP Semiconductors takes no responsibility for the content in this document if provided by an information source outside of NXP Semiconductors.

In no event shall NXP Semiconductors be liable for any indirect, incidental, punitive, special or consequential damages (including - without limitation - lost profits, lost savings, business interruption, costs related to the removal or replacement of any products or rework charges) whether or not such damages are based on tort (including negligence), warranty, breach of contract or any other legal theory.

Notwithstanding any damages that customer might incur for any reason whatsoever, NXP Semiconductors' aggregate and cumulative liability towards customer for the products described herein shall be limited in accordance with the Terms and conditions of commercial sale of NXP Semiconductors.

Right to make changes — NXP Semiconductors reserves the right to make changes to information published in this document, including without limitation specifications and product descriptions, at any time and without notice. This document supersedes and replaces all information supplied prior to the publication hereof.

plastic thermal enhanced very thin quad flat package; no leads; 72 terminals, 0.5 mm pitch, 10 mm x 10 mm x 0.85 mm body

Contents

1 Package summary1
2 Package outline2
3 Soldering3
4 Legal information4