

# **ZK-HC08EY-A**

## **Schematic and Bill of Material**

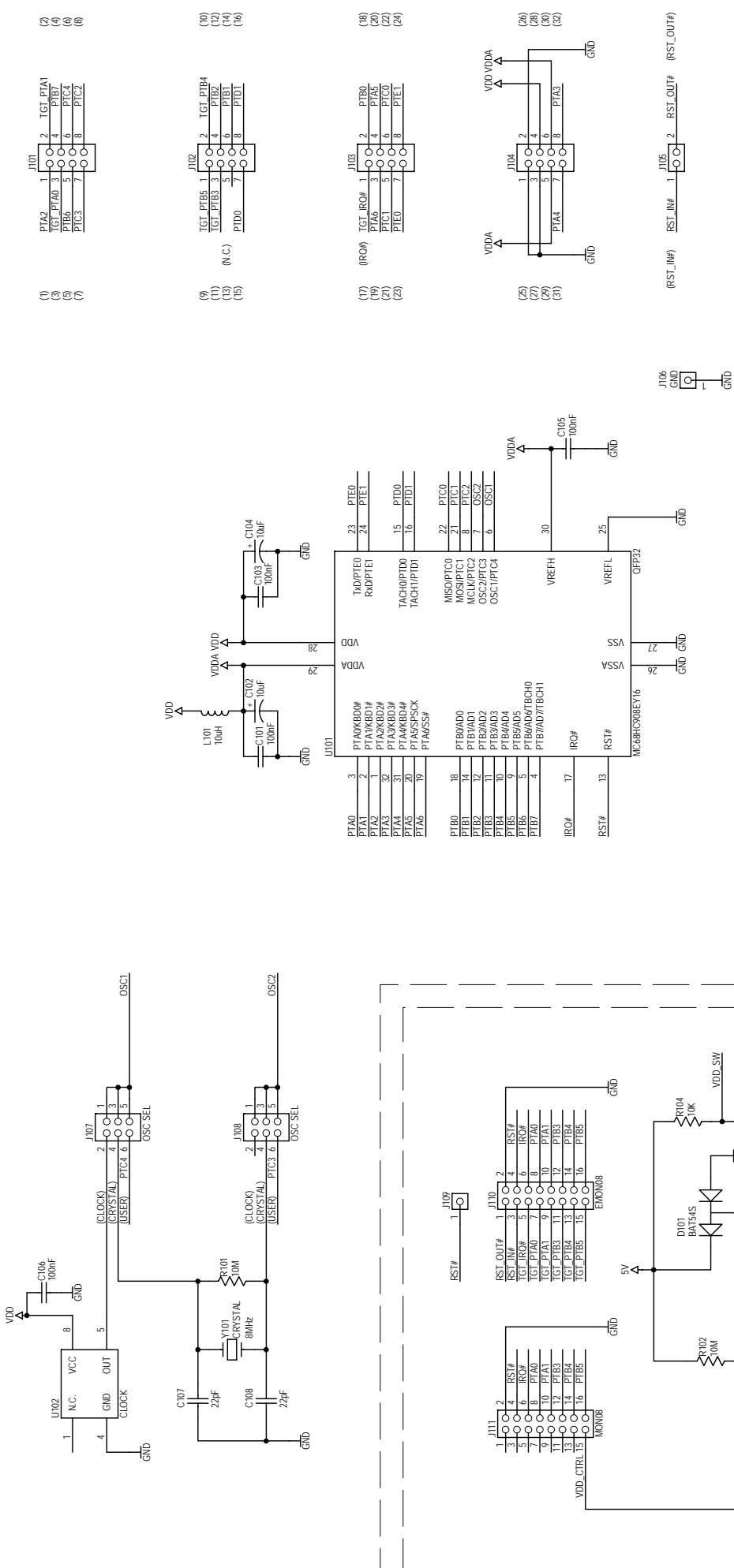

MON08 CONNECTORS

MCU

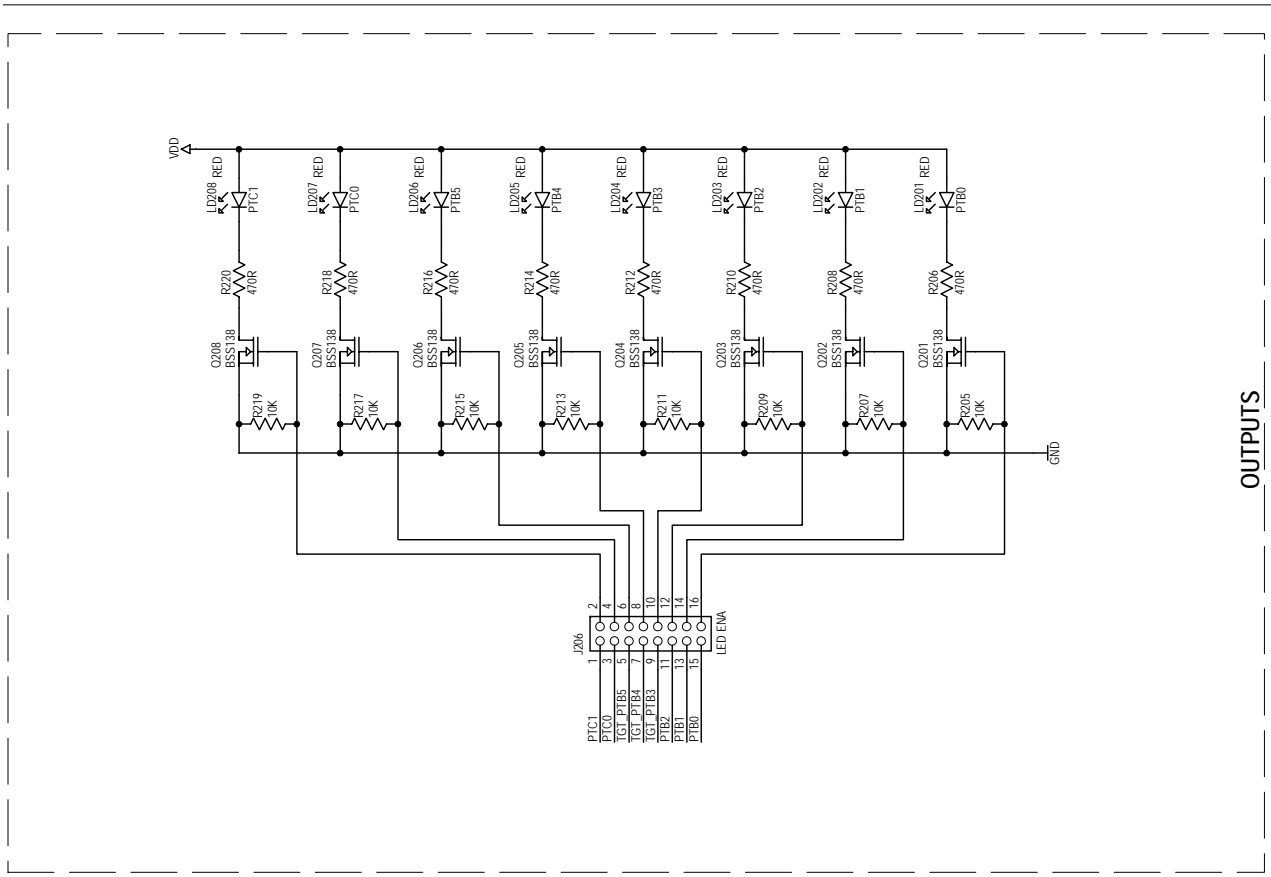

OUTPUTS

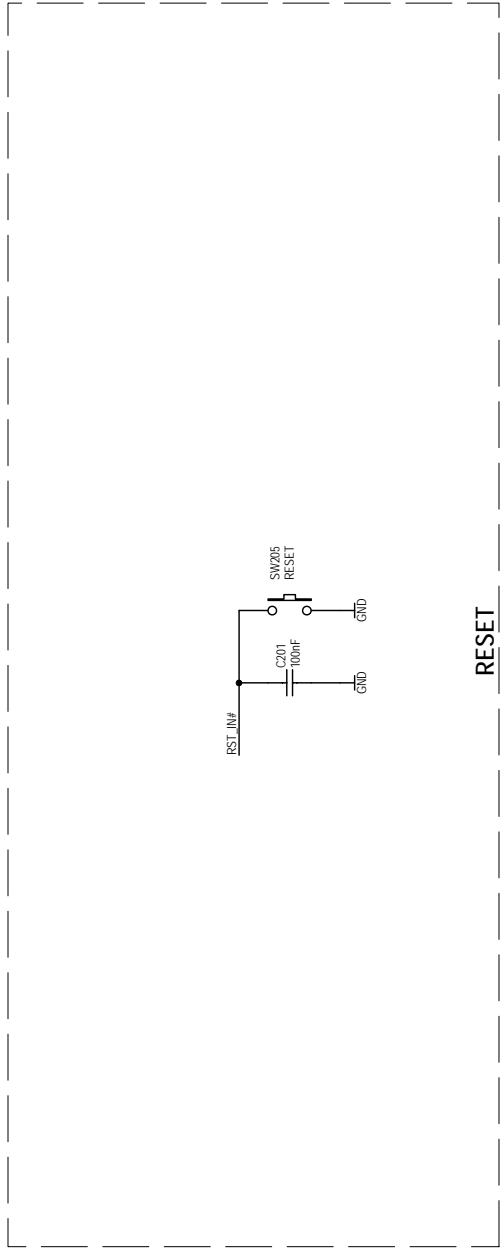

RESET

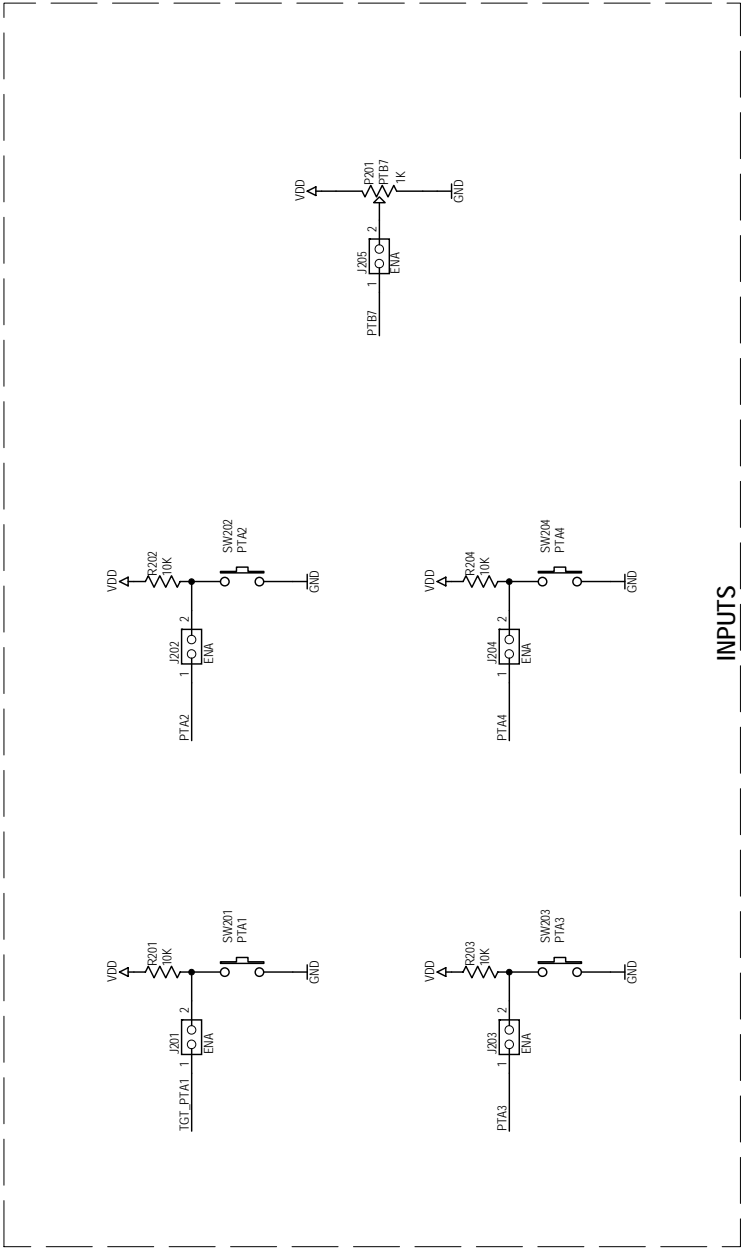

INPUTS

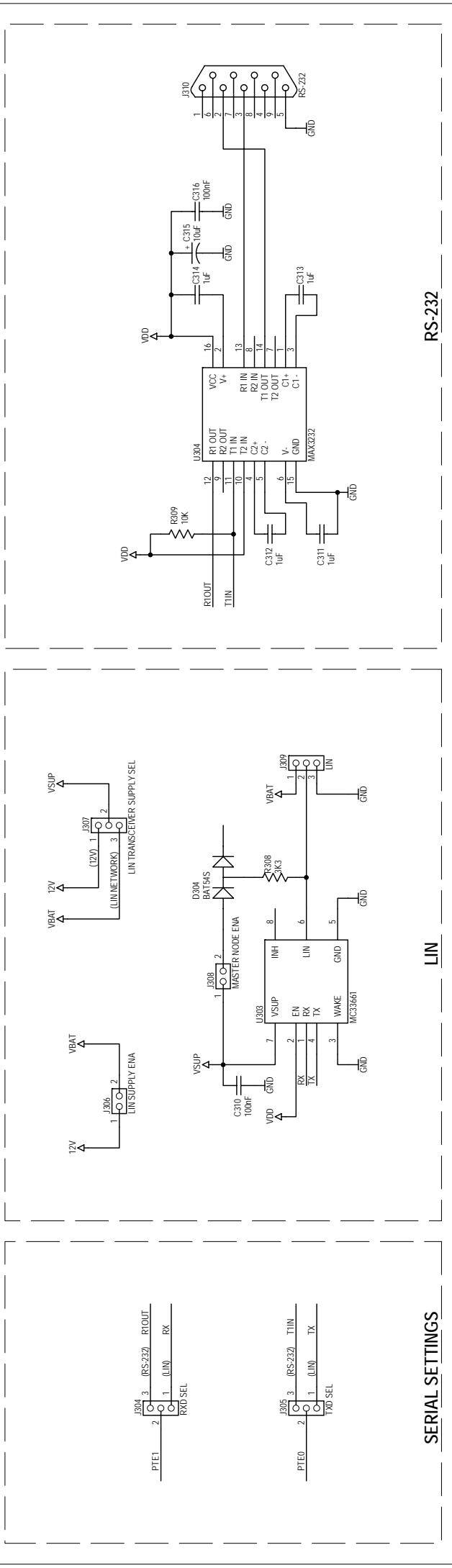
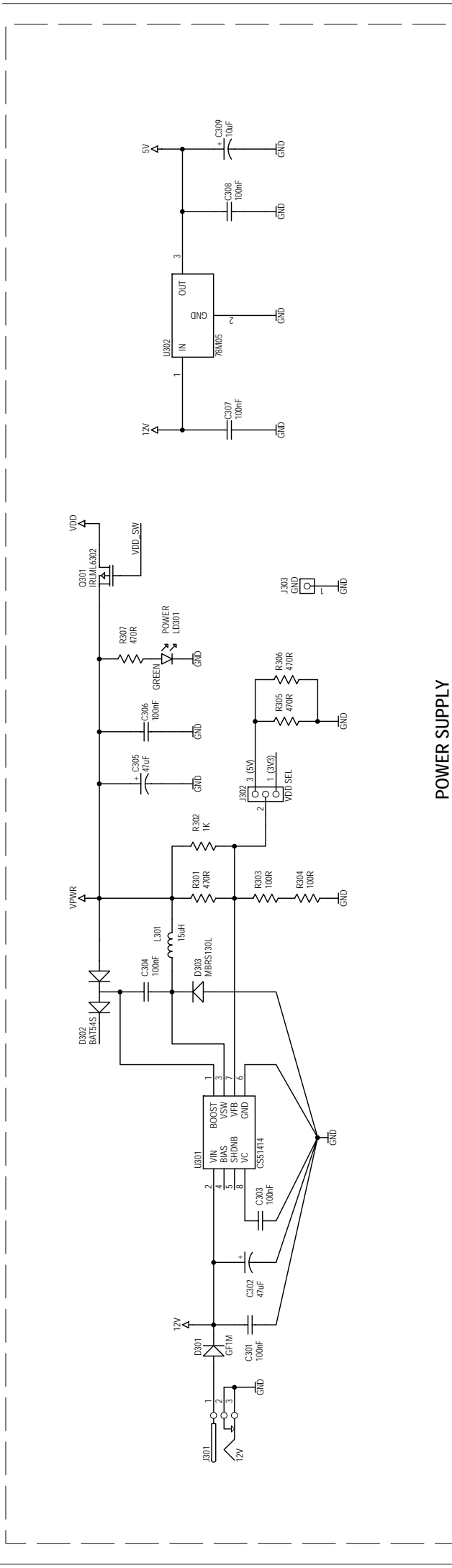

RS-232

LIN

SERIAL SETTINGS

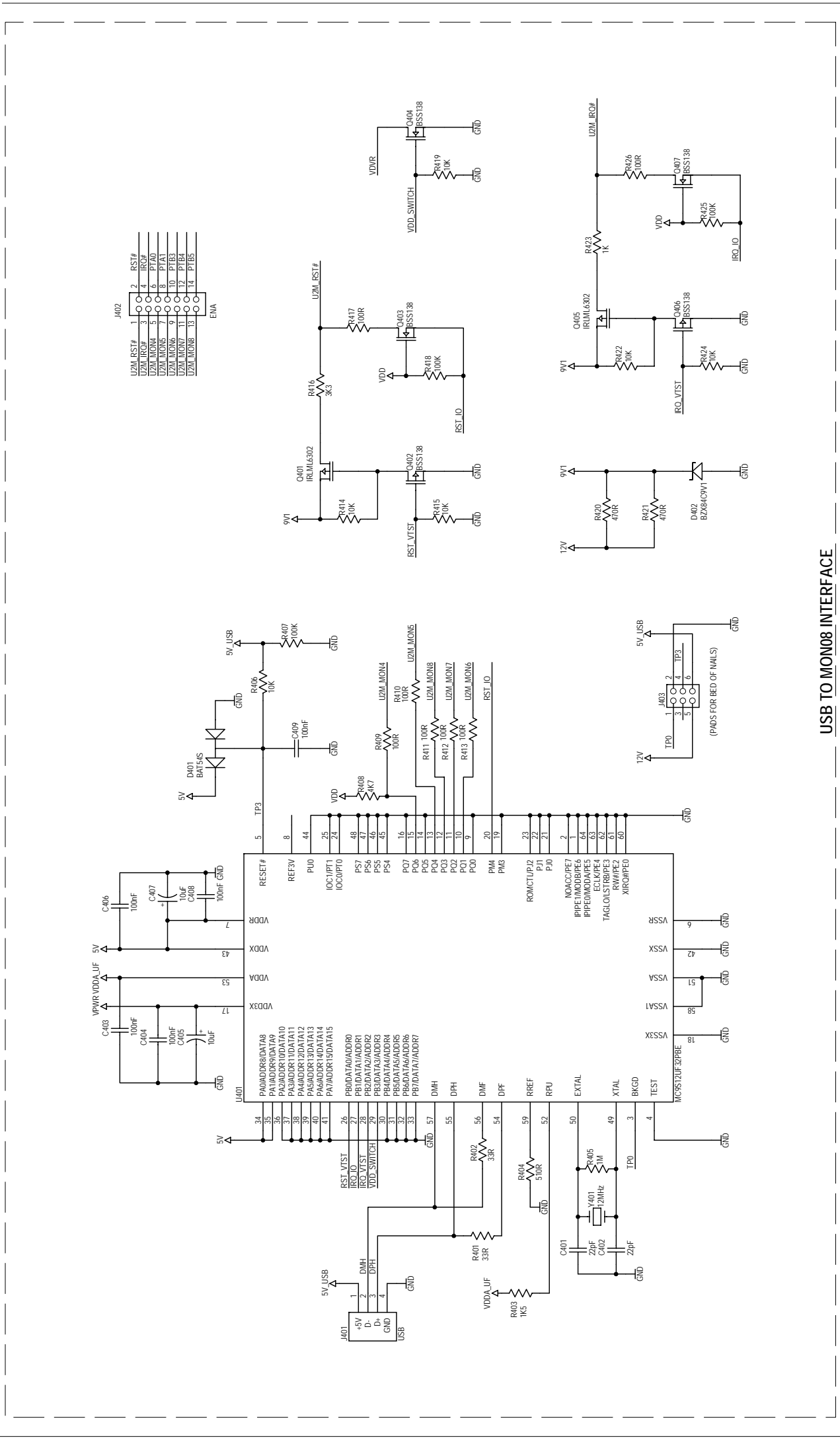

USB TO MON08 INTERFACE

## ZK-HC08EY-A Bill of Material

Qty	Description	Ref. Designators	Vendor Part#
<b>Capacitors</b>			
18	Ceramic Capacitor 100nF X7R 50V 0805	C101, C103, C105, C106, C201, C301, C303, C304, C306, C307, C308, C310, C316, C403, C404, C406, C408, C409	Walsin, 0805B104K500CT
4	Ceramic Capacitor 1uF X7R 25V 0805	C311, C312, C313, C314	Walsin, 0805B105K250CT
4	Ceramic Capacitor 22pF NP0 50V 0805	C107, C108, C401, C402	Walsin, 0805N220K500CT
6	Tantalum Capacitor 10uF 16V size B	C102, C104, C309, C315, C405, C407	NIC Components, NTC-T106M16TRBF
2	Tantalum Capacitor 47uF 16V (low ESR) size D	C302, C305	NIC Components, NTC-L476M16TRD
<b>Connectors</b>			
1	AMP MODU II Connector AMP 2X1 male 180° PCB solder 2-way	J112	AMP, 280370-1
1	DC Power Connector 2.1 mm male 90° PCB mounting	J301	Samar, 22HP037
1	D-Sub Connector 9 pin female 90°	J310	Coxoc, 205A-09FSTUBE3
1	Header Connector 1x1 pin male gold straight 6mm pitch 2,54mm	J109	Coxoc, 307A-040GASAA3
8	Header Connector 2x1 pin male gold straight 6mm pitch 2,54mm	J105, J201, J202, J203, J204, J205, J306, J308	Coxoc, 307A-040GASAA3
5	Header Connector 3x1 pin male gold straight 6mm pitch 2,54mm	J302, J304, J305, J307, J309	Coxoc, 307A-040GASAA3
2	Header Connector 3x2 pin male gold straight 6mm pitch 2,54mm	J107, J108	Coxoc, 307A-080GBSAA3
4	Header Connector 4x2 pin male gold straight 6mm pitch 2,54mm	J101, J102, J103, J104	Coxoc, 307A-040GBSAA3
1	Header Connector 7x2 pin male gold straight 6mm pitch 2,54mm	J402	Coxoc, 307A-040GBSAA3
3	Header Connector 8x2 pin male gold straight 6mm pitch 2,54mm	J110, J111, J206	Coxoc, 307A-040GBSAA3
2	PCB Terminal Connector black 1,32mm	J106, J303	William Hughes, 100-103
28	Shunt jumper 2,54mmmm totally insulated black		Coxoc, 308A02PGBA003
1	USB Connector Receptacle Type B 90°	J401	Coxoc, 317A-04PSB0003
<b>Crystals</b>			
1	SMD Crystal 12MHz HC-49USMD (11x5x3)	Y401	Megatec, HC49/USM4-012M000000CR
1	SMD Crystal 8MHz HC-49USMD (11x5x3)	Y101	Megatec, HC49/USM4-008M000000CR
<b>Diodes</b>			
1	Rectifier Diode GF1M SMA	D301	Fairchild Semiconductor, GF1M
4	Schottky Diode BAT54S SOT23	D101, D302, D304, D401	Philips, BAT54S
1	Schottky Diode MBRS130L SMB	D303	On Semiconductor, MBRS130LT3G
1	Zener Diode BZX84 9.1V 1/4W SOT23	D402	Philips, BZX84-A9V1
<b>Inductors</b>			
1	SMD Inductor 10uH 150mA 1210	L101	TDK, NL322522T-100J
1	SMD Inductor 15uH 1,47A 2-pin	L301	Würth, 744777115
<b>Integrated Circuits</b>			
1	IC Microcontroller MC9S12UF32 LQFP64	U401	Freescale, MC9S12UF32PB
1	IC Transceiver LIN MC33661 SOIC8	U303	Freescale, MC33661D/R2
1	IC Transceiver RS-232 MAX3232 SOIC16	U304	STMicroelectronics, ST3232CD
1	IC Voltage Regulator CS51414 SOIC8	U301	On Semiconductor, CS51414G
1	IC Voltage Regulator LM78M05 5V TO252 (DPAK)	U302	National Semiconductor, LM78M05CDT
<b>LEDs</b>			

Qty	Description	Ref. Designators	Vendor Part#
1	SMD LED Green 1206	LD301	Agilent Technologies, HSMG-C150
8	SMD LED Red 1206	LD201, LD202, LD203, LD204, LD205, LD206, LD207, LD208	Agilent Technologies, HSMH-C150
<b>Potentiometers</b>			
1	Potentiometer 1K vertical adjust	P201	Phier, PT10MVP102A2020
<b>Resistors</b>			
1	SMD Resistor 1,5K 1% 0805	R403	Kamaya, RMC1/10K1501FTP
3	SMD Resistor 100K 1% 0805	R407, R418, R425	Kamaya, RMC1/10K1003FTP
9	SMD Resistor 100R 1% 0805	R303, R304, R409, R410, R411, R412, R413, R417, R426	Kamaya, RMC1/10K1000FTP
20	SMD Resistor 10K 1% 0805	R104, R201, R202, R203, R204, R205, R207, R209, R211, R213, R215, R217, R219, R309, R406, R414, R415, R419, R422, R424	Kamaya, RMC1/10K1002FTP
2	SMD Resistor 10M 1% 0805	R101, R102	Kamaya, RMC1/10K1005FTP
2	SMD Resistor 1K 1% 0805	R302, R423	Kamaya, RMC1/10K1001FTP
1	SMD Resistor 1M 1% 0805	R405	Kamaya, RMC1/10K1004FTP
2	SMD Resistor 3,3K 1% 0805	R308, R416	Kamaya, RMC1/10K3301FTP
2	SMD Resistor 33R 1% 0805	R401, R402	Kamaya, RMC1/10K33R0FTP
2	SMD Resistor 4,7K 1% 0805	R103, R408	Kamaya, RMC1/10K4701FTP
14	SMD Resistor 470R 1% 0805	R206, R208, R210, R212, R214, R216, R218, R220, R301, R305, R306, R307, R420, R421	Kamaya, RMC1/10K4700FTP
1	SMD Resistor 510R 1% 0805	R404	Kamaya, RMC1/10K5100FTP
<b>Sockets</b>			
1	IC Socket 4(8) pin tulip for oscillator module DIP4	U102	E-tec, COS-084-S001-01
1	ZIF IC Socket QFP32	U101	Yamaichi, IC51-1498AC-20545
<b>Switches</b>			
5	Push Button SMD	SW201, SW202, SW203, SW204, SW205	Augat, FSM4JSMA
<b>Transistors</b>			
14	NMOS Transistor BSS138 SOT23	Q101, Q201, Q202, Q203, Q204, Q205, Q206, Q207, Q208, Q402, Q403, Q404, Q406, Q407	On Semiconductor, BSS138LT1G
3	PMOS Transistor IRLML6302 SOT23	Q301, Q401, Q405	International Rectifier, IRLML6302TRPBF