

ZK-HC08AX-A

Schematic and Bill of Material

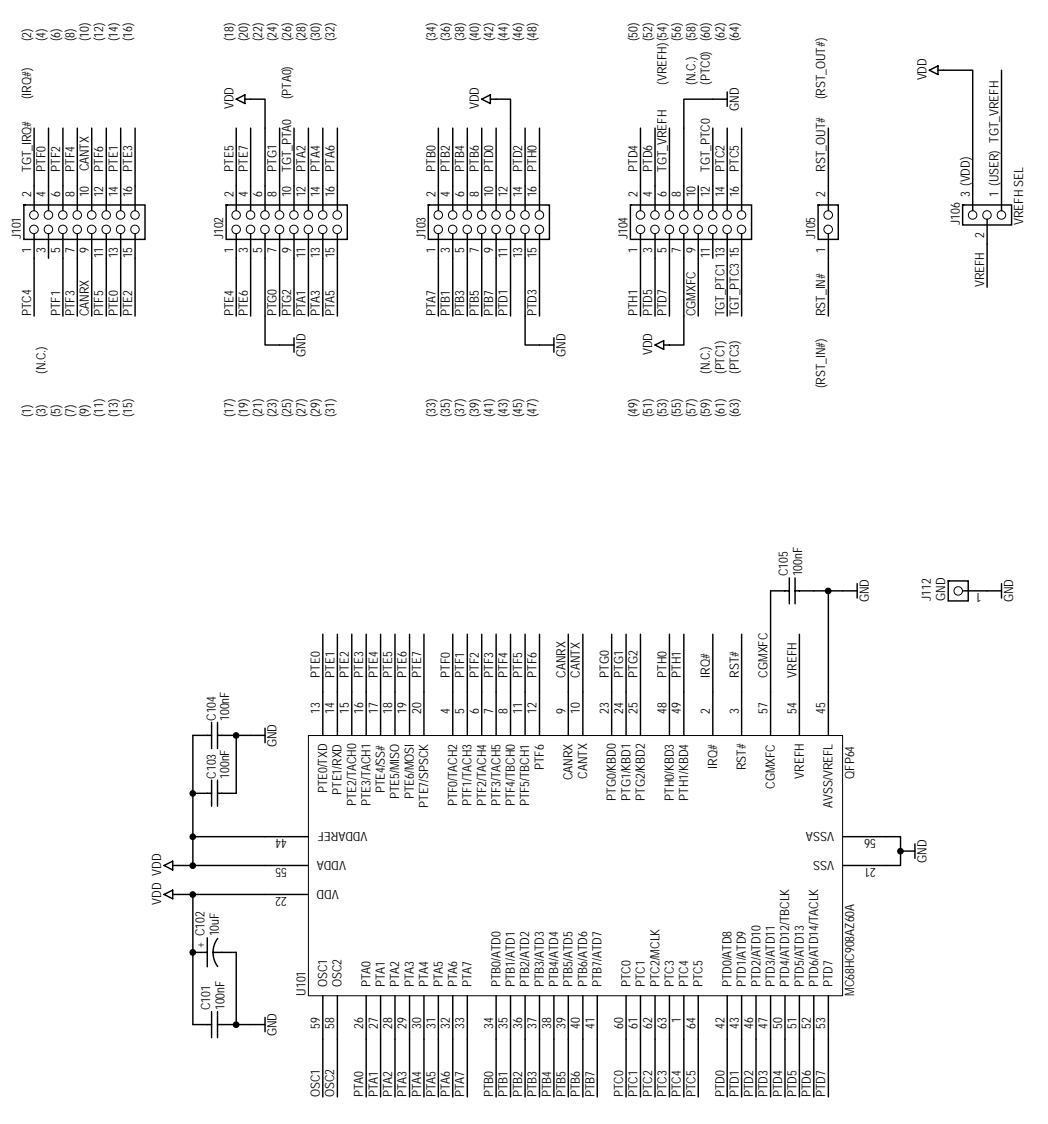
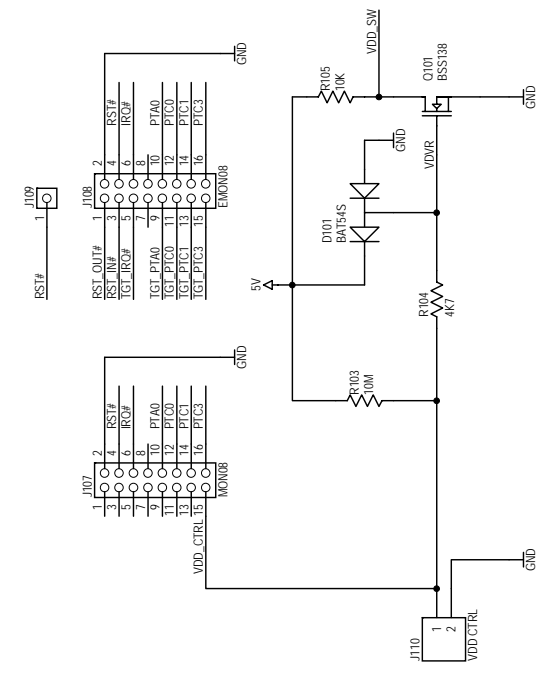
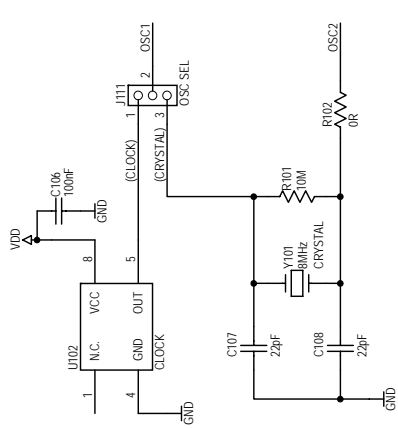

MON08 CONNECTORS

MCU

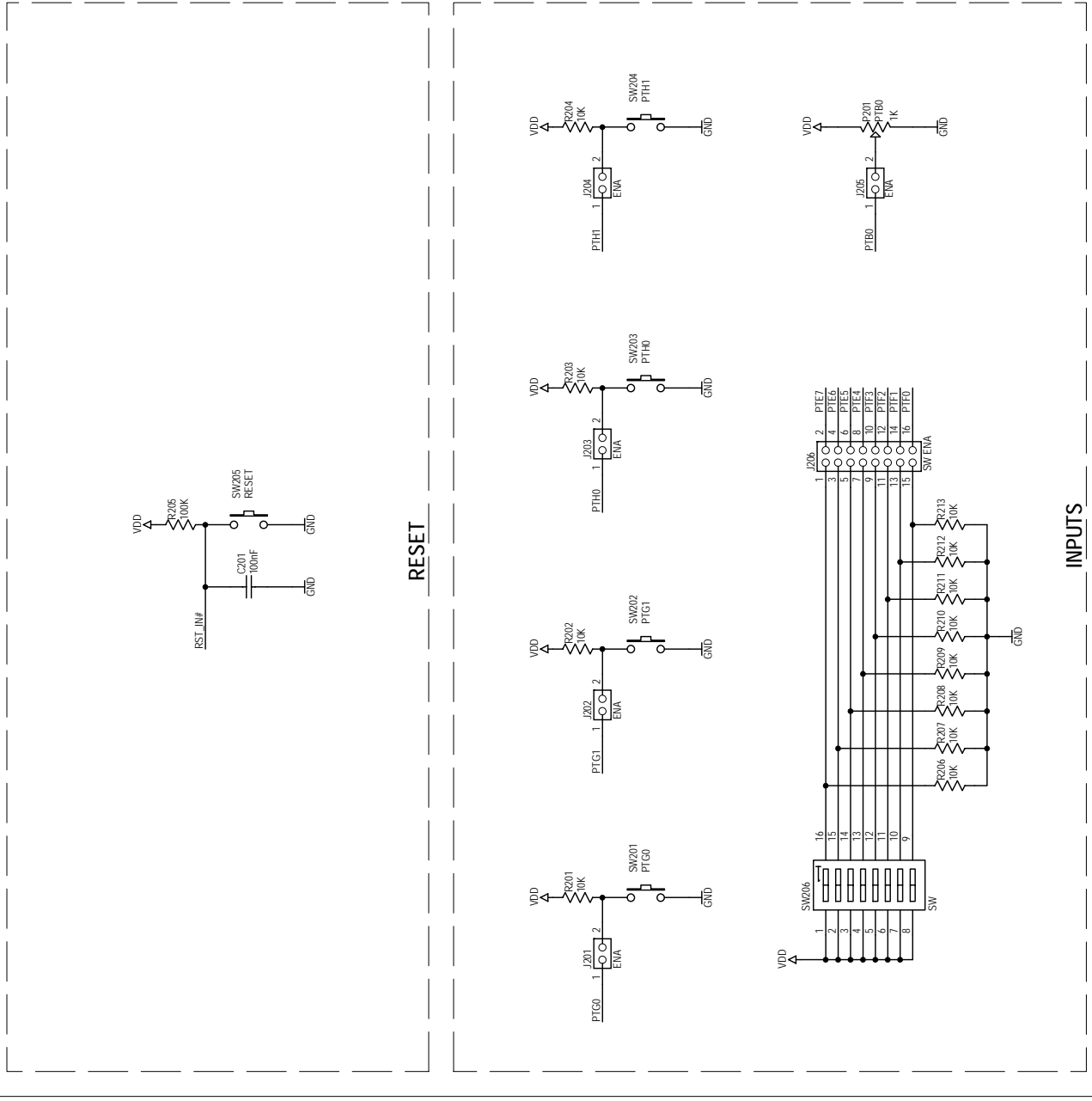

RESET

INPUTS

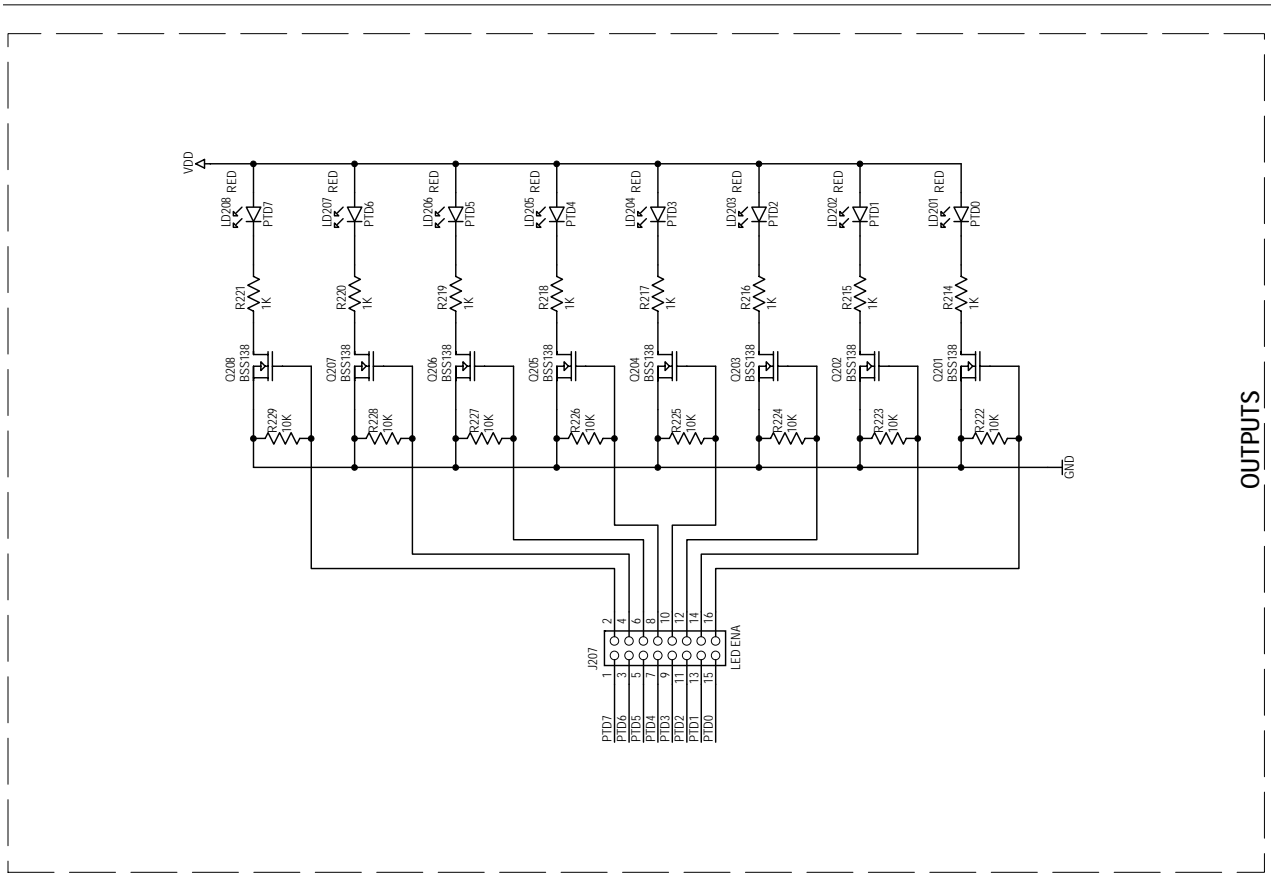

OUTPUTS

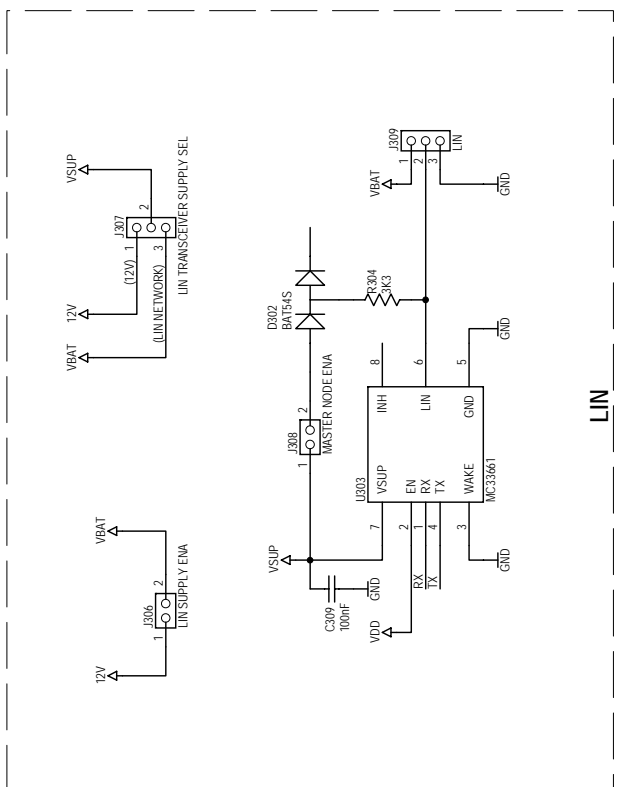
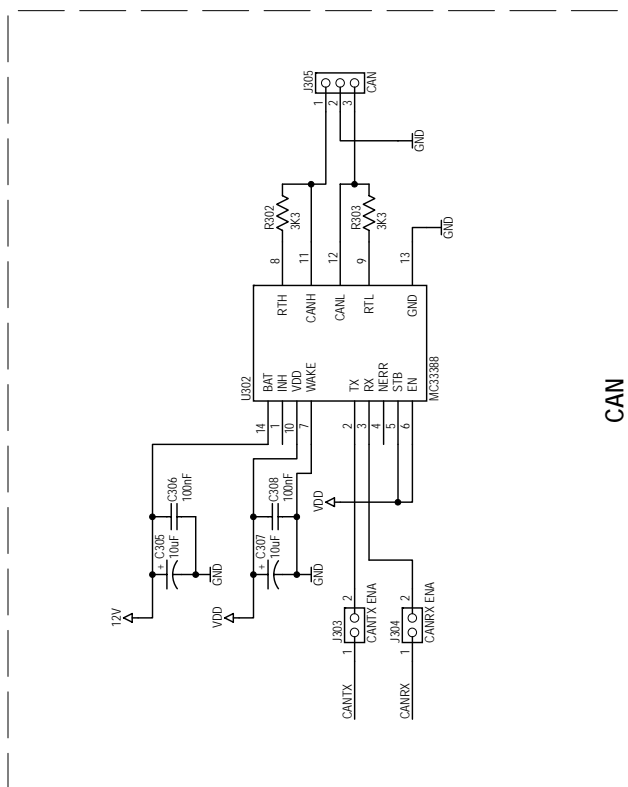
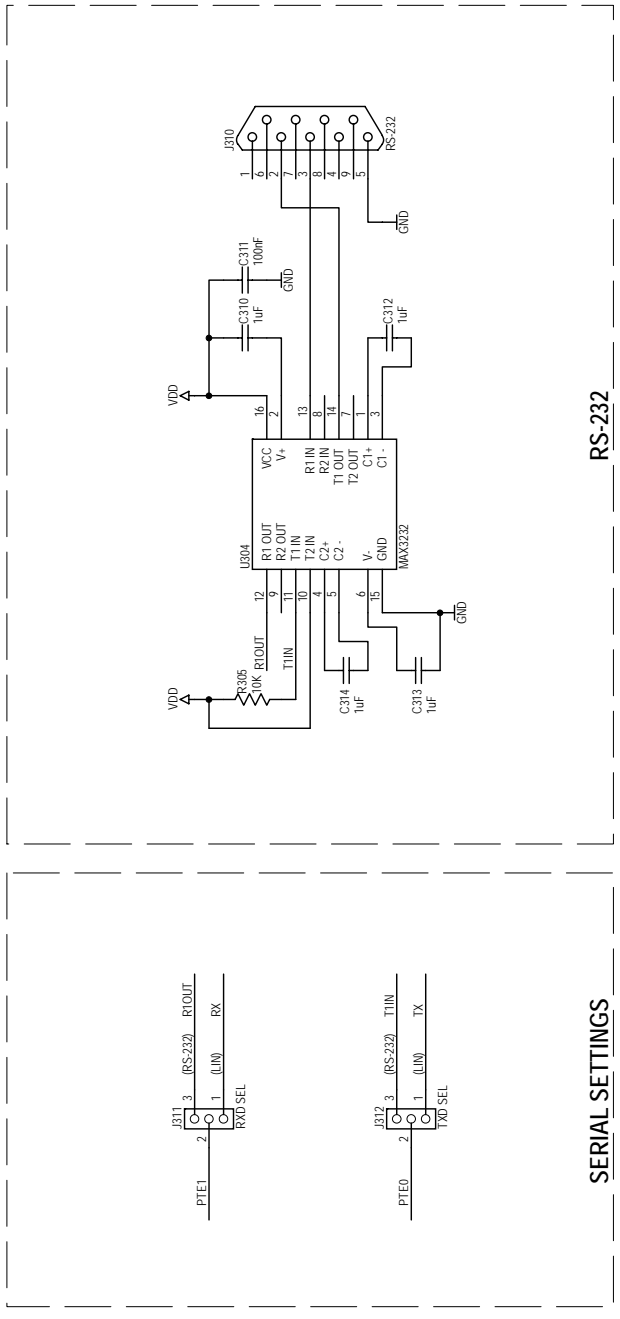
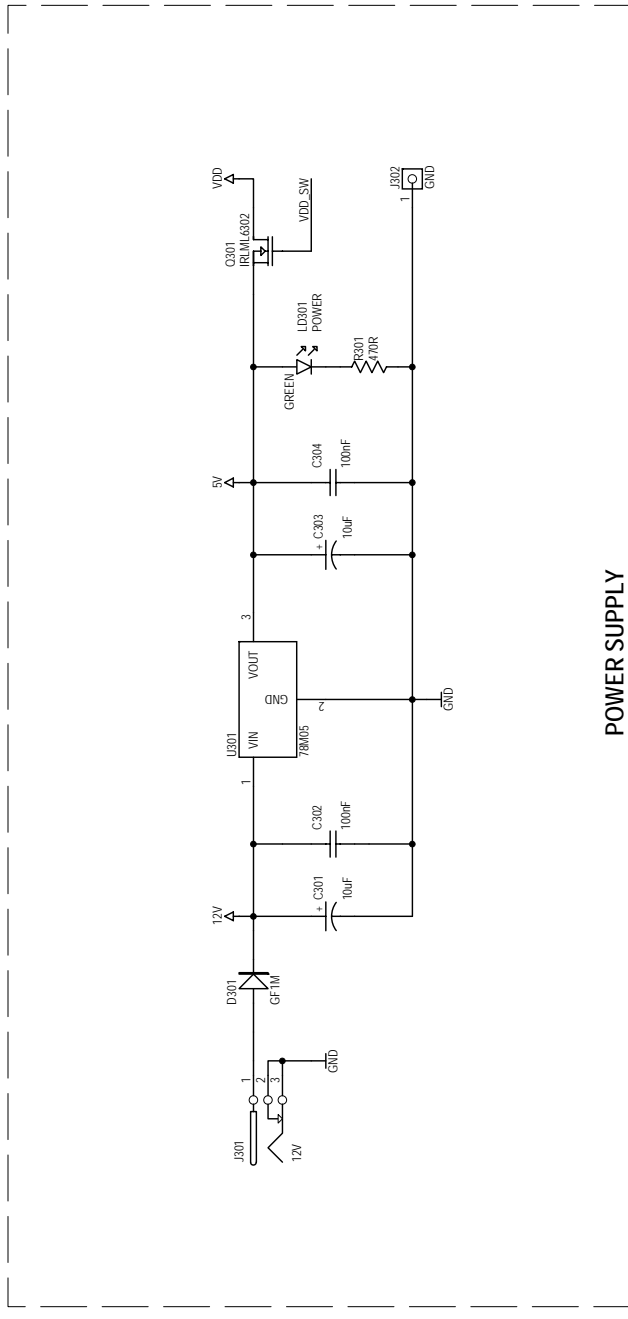

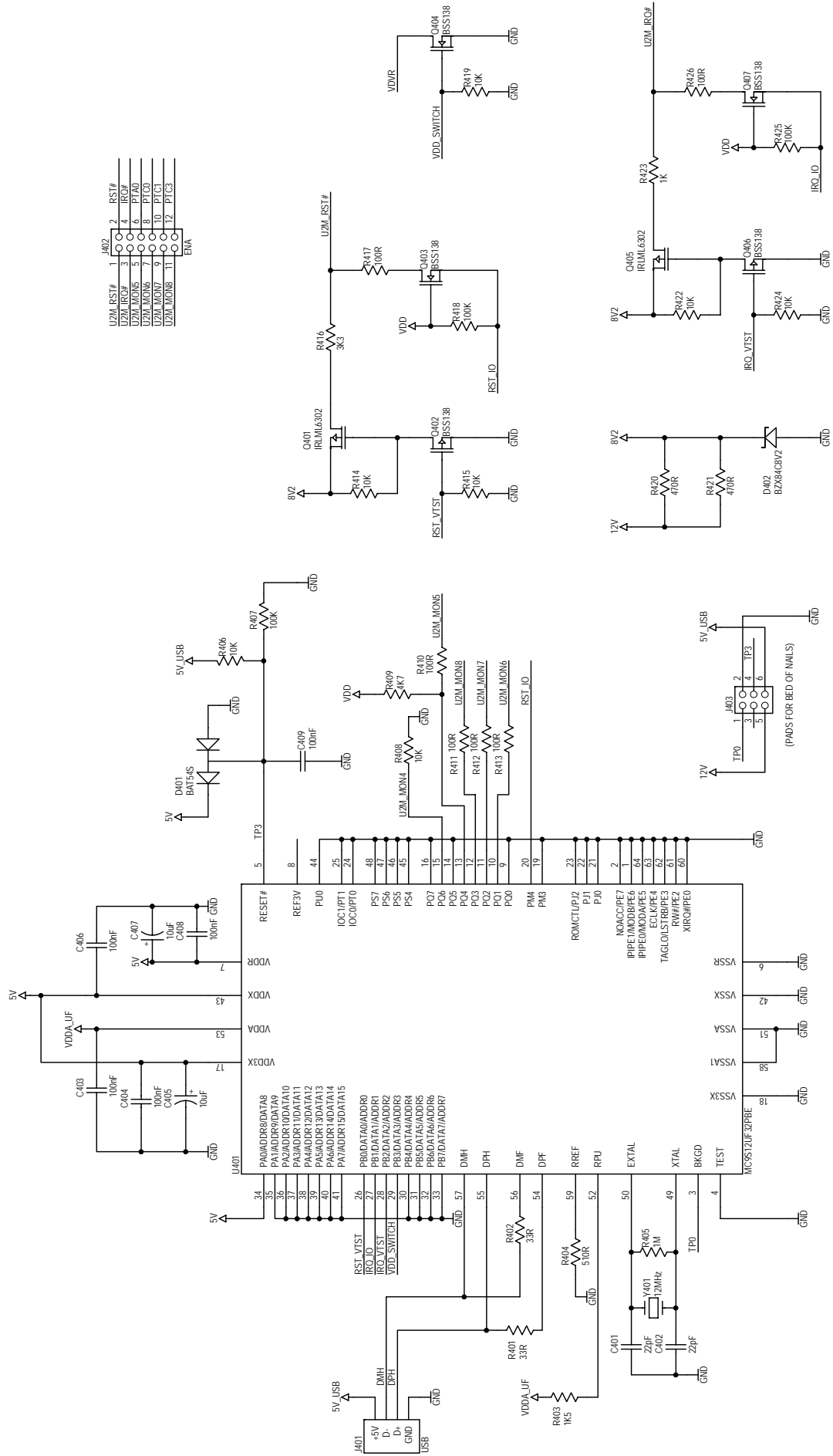

USB TO MON08 INTERFACE

ZK-HC08AX-A Bill of Material

Qty	Description	Ref. Designators	Vendor Part#
Capacitors			
17	Ceramic Capacitor 100nF X7R 50V 0805	C101, C103, C104, C105, C106, C201, C302, C304, C306, C308, C309, C311, C403, C404, C406, C408, C409	Walsin, 0805B104K500CT
4	Ceramic Capacitor 1uF X7R 25V 0805	C310, C312, C313, C314	Walsin, 0805B105K250CT
4	Ceramic Capacitor 22pF NP0 50V 0805	C107, C108, C401, C402	Walsin, 0805N220K500CT
7	Tantalum Capacitor 10uF 16V size B	C102, C301, C303, C305, C307, C405, C407	NIC Components, NTC-T106M16TRBF
Connectors			
1	AMP MODU II Connector AMP 2X1 male 180° PCB solder 2-way	J110	AMP, 280370-1
1	DC Power Connector 2.1 mm male 90° PCB mounting	J301	Samar, 22HP037
1	D-Sub Connector 9 pin female 90°	J310	Coxoc, 205A-09FSTUBE3
1	Header Connector 1x1 pin male gold straight 6mm pitch 2,54mm	J109	Coxoc, 307A-040GASAA3
10	Header Connector 2x1 pin male gold straight 6mm pitch 2,54mm	J105, J201, J202, J203, J204, J205, J303, J304, J306, J308	Coxoc, 307A-040GASAA3
7	Header Connector 3x1 pin male gold straight 6mm pitch 2,54mm	J106, J111, J305, J307, J309, J311, J312	Coxoc, 307A-040GASAA3
1	Header Connector 6x2 pin male gold straight 6mm pitch 2,54mm	J402	Coxoc, 307A-040GBSAA3
8	Header Connector 8x2 pin male gold straight 6mm pitch 2,54mm	J101, J102, J103, J104, J107, J108, J206, J207	Coxoc, 307A-040GBSAA3
2	PCB Terminal Connector black 1,32mm	J112, J302	William Hughes, 100-103
36	Shunt jumper 2,54mmmm totally insulated black		Coxoc, 308A02PGBA003
1	USB Connector Receptacle Type B 90°	J401	Coxoc, 317A-04PSB0003
Crystals			
1	SMD Crystal 12MHz HC-49USMD (11x5x3)	Y401	Megatec, HC49/USM4-012M000000CR
1	SMD Crystal 8MHz HC-49USMD (11x5x3)	Y101	Megatec, HC49/USM4-008M000000CR
Diodes			
1	Rectifier Diode GF1M SMA	D301	Fairchild Semiconductor, GF1M
3	Schottky Diode BAT54S SOT23	D101, D302, D401	Philips, BAT54S
1	Zener Diode BZX84 8.2V 1/4W SOT23	D402	Philips, BZX84-A8V2
Integrated Circuits			
1	IC Microcontroller MC9S12UF32 LQFP64	U401	Freescale, MC9S12UF32PB
1	IC Transceiver CAN MC33388 SOIC14	U302	Freescale, MC33388D
1	IC Transceiver LIN MC33661 SOIC8	U303	Freescale, MC33661D/R2
1	IC Transceiver RS-232 MAX3232 SOIC16	U304	STMicroelectronics, ST3232CD
1	IC Voltage Regulator LM78M05 5V TO252 (DPAK)	U301	National Semiconductor, LM78M05CDT
LEDs			
1	SMD LED Green 1206	LD301	Agilent Technologies, HSMG-C150
8	SMD LED Red 1206	LD201, LD202, LD203, LD204, LD205, LD206, LD207, LD208	Agilent Technologies, HSMH-C150
Potentiometers			
1	Potentiometer 1K vertical adjust	P201	Phier, PT10MVP102A2020
Resistors			
1	SMD Resistor 0R 5% 1/8W 0805	R102	Kamaya, RMC1/10JPTP
1	SMD Resistor 1,5K 1% 0805	R403	Kamaya, RMC1/10K1501FTP
4	SMD Resistor 100K 1% 0805	R205, R407, R418, R425	Kamaya, RMC1/10K1003FTP

Qty	Description	Ref. Designators	Vendor Part#
6	SMD Resistor 100R 1% 0805	R410, R411, R412, R413, R417, R426	Kamaya, RMC1/10K1000FTP
29	SMD Resistor 10K 1% 0805	R105, R201, R202, R203, R204, R206, R207, R208, R209, R210, R211, R212, R213, R222, R223, R224, R225, R226, R227, R228, R229, R305, R406, R408, R414, R415, R419, R422, R424	Kamaya, RMC1/10K1002FTP
2	SMD Resistor 10M 1% 0805	R101, R103	Kamaya, RMC1/10K1005FTP
9	SMD Resistor 1K 1% 0805	R214, R215, R216, R217, R218, R219, R220, R221, R423	Kamaya, RMC1/10K1001FTP
1	SMD Resistor 1M 1% 0805	R405	Kamaya, RMC1/10K1004FTP
4	SMD Resistor 3,3K 1% 0805	R302, R303, R304, R416	Kamaya, RMC1/10K3301FTP
2	SMD Resistor 33R 1% 0805	R401, R402	Kamaya, RMC1/10K33R0FTP
2	SMD Resistor 4,7K 1% 0805	R104, R409	Kamaya, RMC1/10K4701FTP
3	SMD Resistor 470R 1% 0805	R301, R420, R421	Kamaya, RMC1/10K4700FTP
1	SMD Resistor 510R 1% 0805	R404	Kamaya, RMC1/10K5100FTP
Sockets			
1	IC Socket 4(8) pin tulip for oscillator module DIP4	U102	E-tec, COS-084-S001-01
1	ZIF IC Socket QFP64	U101	Yamaichi, IC51-0644-824-1
Switches			
1	DIP Switch PTH low profile 8 positions DIP16	SW206	Tyco, 2-1437586-6
5	Push Button SMD	SW201, SW202, SW203, SW204, SW205	Augat, FSM4JSMA
Transistors			
14	NMOS Transistor BSS138 SOT23	Q101, Q201, Q202, Q203, Q204, Q205, Q206, Q207, Q208, Q402, Q403, Q404, Q406, Q407	On Semiconductor, BSS138LT1G
3	PMOS Transistor IRLML6302 SOT23	Q301, Q401, Q405	International Rectifier, IRLML6302TRPBF