

NTM88Hxx5S

Tire pressure monitor sensor

Rev. 1.3 — 5 December 2023

Objective data sheet

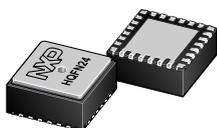

1 General description

The NTM88 family consists of small (4 mm x 4 mm x 1.98 mm), fully integrated tire pressure monitoring sensors (TPMS). The devices described in this data sheet, NTM88Hxx5S, provide low transmitting power consumption, large customer memory size, and single- or dual-axis accelerometer architecture. The NTM88Hxx5S TPMS solution integrates an 8-bit microcontroller (MCU), pressure sensor, accelerometers in four ranges, programmable RF transmitter and flexible LF receiver. The sensor supports seven GPIOs, client SPI, and a 2-channel timer / pulse-width module.

2 Features and benefits

- Optional pressure ranges¹
- Optional accelerometer ranges: See [Section 3](#).
- Transducer measurement interfaces with low-power AFE:
 - 10-bit compensated pressure sense element
 - 10-bit compensated accelerometers
 - 8-bit compensated internal device temperature measurement
 - 8-bit compensated internal device voltage measurement
 - Two I/O pins can be used for external signals
- 8-bit S08 compact instruction set controller:
 - 64 bytes low-power “always on” NVM parameter registers
 - 512 bytes SRAM
 - 16 kB flash memory (512 bytes reserved for NXP coefficients)
 - Family of NXP firmware libraries available via royalty-free license
- Programmable RF transmitter
 - Characterized for RF carrier typical of 315 MHz or 434 MHz
 - Characterized for FSK in ~3 kHz increments or OOK modulation
 - Characterized for baud rate examples of 9.6 kbp/s, 19.2 kbp/s, and 38.4 kbp/s
- Flexible 125 kHz LF receiver:
 - Capability for ASK or OOK demodulation
 - Automated Manchester decoding
- Two channel timer / pulse-width module
- Client SPI to support host access to internal peripherals, registers, and memory
- Seven GPIOs with programmable multiplexing to support software development, external analog voltage input, timer, SPI, and wake-up
- Qualified in compliance with AEC-Q100, Rev. H

¹ Consult NXP sales for details or specific requests.



- Long battery service life
- Internal temperature sensor
- Internal voltage sensor
- Six-channel, 8-, 10-, or 12-bit analog-to-digital converter (ADC10) with two external I/O inputs
- Internal 315-/434-M Hz RF transmitter
 - External crystal oscillator
 - PLL-based output with fractional-n divider
 - OOK and FSK modulation capability
 - Programmable data rate generator
 - Manchester, Bi-Phase, or NRZ data encoding
 - 256-bit RF data buffer variable length interrupt
 - Direct access to RF transmitter from MCU for unique formats
 - Low-power consumption
- Differential input LF detector/decoder on independent signal pins
- Real-time Interrupt driven by LFO with intervals of 2, 4, 8, 16, 32, 64, or 128 ms
- Free-running counter, low-power, wake up timer and periodic reset driven by LFO
- Watchdog timeout with selectable times and clock sources
- Two-channel general-purpose timer/PWM module (TPM1)
- Internal oscillators
 - MCU bus clock of 0.5, 1, 2, and 4 MHz (1, 2, 4, and 8 MHz HFO)
 - Low frequency, low-power time clock (LFO) with 1 ms period
 - Medium frequency, controller clock (MFO) of 8 μs period
- Low-voltage detection

3 Ordering information

Table 1. Ordering information

| Type number | Package | | |
|-------------|---------|---|--------------|
| | Name | Description | Version |
| NTM88Hxx5S | HQFN24 | Plastic thermal enhanced quad flat package; no leads, 0.1 dimple wettable flank; 24 terminals; 0.5 mm pitch, 4 mm x 4 mm x 1.98 mm body | SOT1931-1(D) |

Table 2. Ordering options

| Part Number 'N8' | Pressure Range 'p' | Accelerometer 'aa' | X-axis Range | Z-axis Range | CodeH Hardware (First Rev) ^[1] | |
|-----------------------------|-----------------------|--------------------|--------------|------------------|---|------|
| NTM88H125ST1 ^[2] | 90 kPa to 930 kPa 'H' | XZ | '12' | –400 g to +400 g | –175 g to +550 g | \$9C |
| NTM88H135ST1 ^[2] | | | '13' | –80 g to +90 g | –360 g to +400 g | \$9D |
| NTM88H145ST1 ^[2] | | | '14' | –360 g to +400 g | –80 g to +90 g | \$9E |
| NTM88H155ST1 ^[2] | | | '15' | –360 g to +400 g | –360 g to +400 g | \$9F |

[1] The value CodeF mentioned in the User Manual UM11227^[1] depicts the version of firmware used by NXP during device tests, and will become \$FF as the device is shipped. The value of CodeF will be replaced again by the version number of the firmware library used by the customer at the time of device final application programming.

[2] Product under development, consult your NXP sales representatives for samples.

4 Block diagram

Figure 1 presents the device's main blocks and their signal interactions. Power management controls and bus control signals are not shown in this block diagram for clarity.

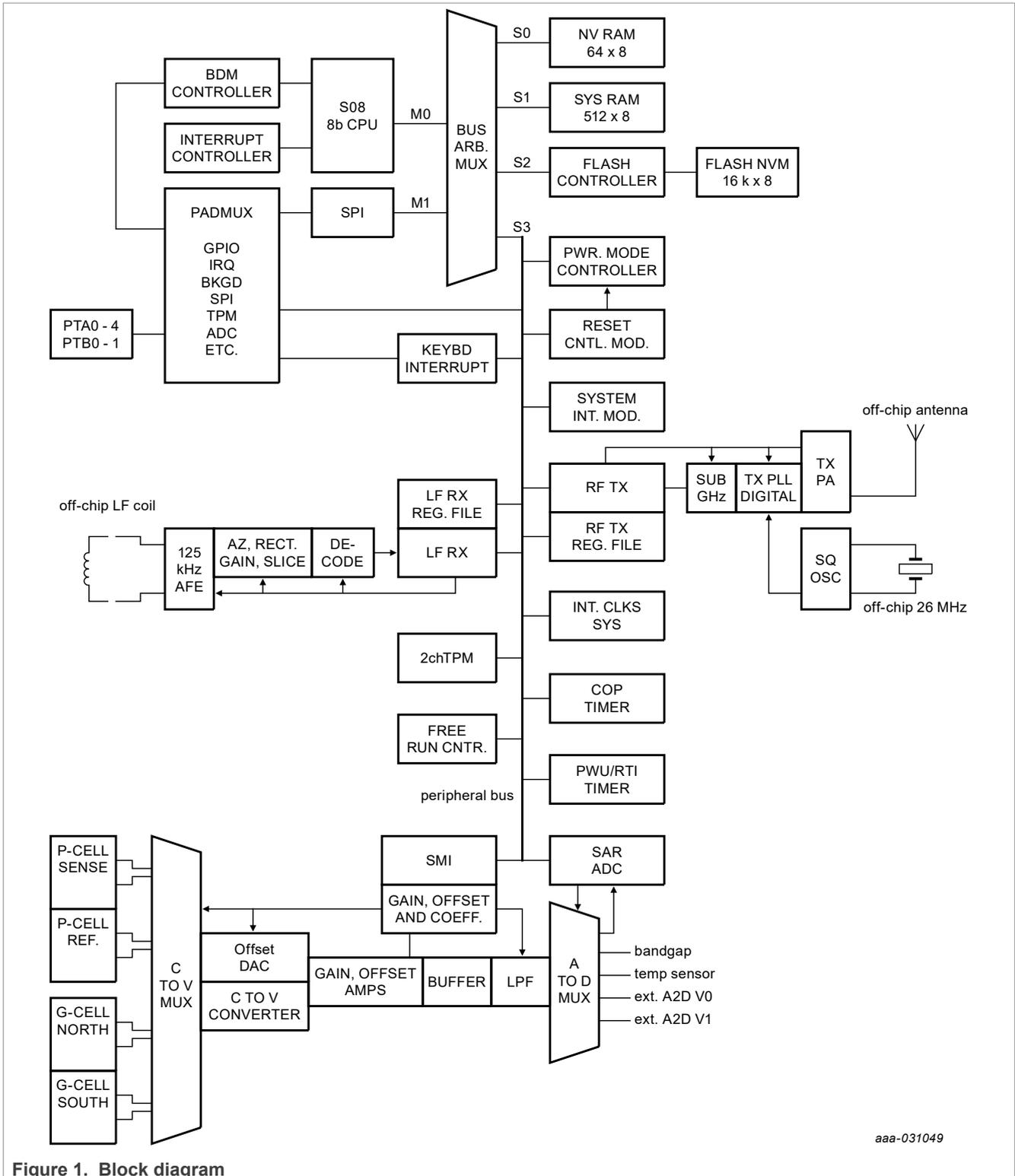

Figure 1. Block diagram

aaa-031049

5 Pinning information

5.1 Pinning

A top view of the device pint with the pressure port on top is show in [Figure 2](#). The orientation of the internal Z-axis accelerometer is shown in [Figure 3](#).

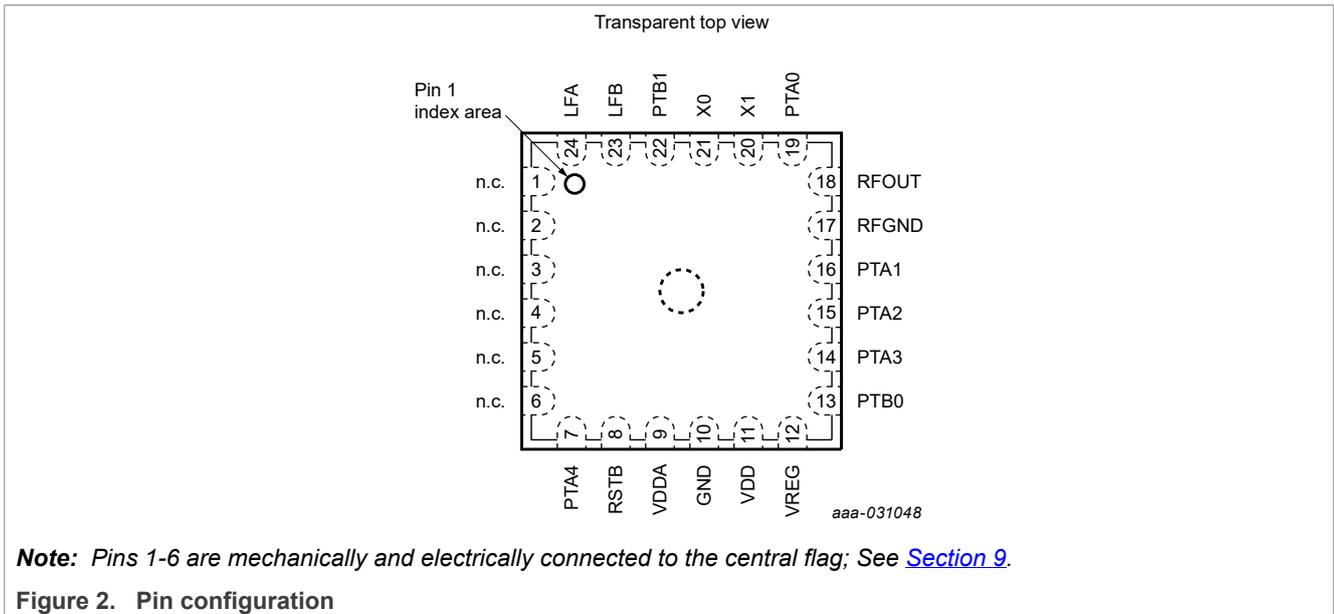

5.2 Pin description

Table 3. Pin description

| Symbol | Pin | Function | Description |
|--------|-----|-------------|---|
| n.c. | 1 | — | Do not connect electrical signals to this pin; solder joint only. |
| n.c. | 2 | — | Do not connect electrical signals to this pin; solder joint only. |
| n.c. | 3 | — | Do not connect electrical signals to this pin; solder joint only. |
| n.c. | 4 | — | Do not connect electrical signals to this pin; solder joint only. |
| n.c. | 5 | — | Do not connect electrical signals to this pin; solder joint only. |
| n.c. | 6 | — | Do not connect electrical signals to this pin; solder joint only. |
| PTA4 | 7 | PTA4 / BKGD | <p>PTA4 Pin - The PTA4 pin places the device in the BACKGROUND DEBUG mode (BDM) to evaluate MCU code and transfer data to/from the internal memory. If the BKGD/PTA4 pin is held low when the device comes out of a power-on-reset (POR), the device switches into the ACTIVE BACKGROUND DEBUG mode (BDM).</p> <p>The BKGD/PTA4 pin has an internal pullup device or can be connected to VDD in the application, unless there is a need to enter BDM operation after the device as been soldered into the PWB. If in-circuit BDM is desired, the BKGD/PTA4 pin should be connected to VDD through a resistor (~10 kΩ or greater) which can be over-driven by an external signal. This resistor reduces the possibility of inadvertently activating the debug mode in the application due to an EMC event.</p> <p>When the application programs port A to GPIOs, PTA4 becomes output-only.</p> |

Table 3. Pin description...continued

| Symbol | Pin | Function | Description |
|--------|-----|--------------------------------------|---|
| RST_B | 8 | Reset / V_{PP} programming voltage | <p>The RST_B pin is used for test and establishing the BDM condition and providing the programming voltage source to the internal FLASH memory. This pin can also be used to direct to the MCU to the reset vector.</p> <p>The RST_B pin has an internal pullup device and can be connected to VDD in the application unless there is a need to enter BDM operation after the device as been soldered to the PWB. If in-circuit BDM is desired, the RST_B pin can be left unconnected; but should be connected to VDD through a low impedance resistor (<10 kΩ) which can be over-driven by an external signal. This low impedance resistor reduces the possibility of getting into the debug mode in the application due to an EMC event.</p> <p>Activation of the external reset function occurs when the voltage on the RST_B pin goes below $0.3 \times V_{DD}$ for at least 100 ns before rising above $0.7 \times V_{DD}$.</p> |
| VDDA | 9 | Analog supply | <p>The analog circuits operate from a single power supply connected to the unit through the VDDA pin. VDDA is the positive supply and GND is the ground. The conductors to the power supply should be connected to the VDDA and GND pins and locally decoupled.</p> <p>Care should be taken to reduce measurement signal noise by separating the VDD, GND, VDDA, and RFGND pins using a "star" connection such that each metal trace does not share any load currents with other external devices.</p> |
| GND | 10 | Digital and analog ground | <p>The digital circuits operate from a single power supply connected to the unit through the VDD and GND pins. GND is the ground. Care should be taken to reduce measurement signal noise by separating the GND and RFGND pins using a "star" connection such that each metal trace does not share any load currents with other external devices.</p> |
| VDD | 11 | Digital supply | <p>The digital circuits operate from a single power supply connected to the unit through the VDD and GND pins. VDD is the positive supply. The conductors to the power supply should be connected to the VDD and GND pins and locally decoupled.</p> |
| VREG | 12 | 1.8 V regulation | <p>The internal regulator for the RF analog circuits requires an external stabilization capacitor to GND.</p> |
| PTB0 | 13 | PTB0 / TPMCH0 / AD3 | <p>The PTB[0] pin is a general-purpose I/O pin. This pin can be configured as a nominal bidirectional I/O pin with programmable pullup devices. User software must configure the general-purpose I/O pin (PTB[1:0]) so that they do not result in "floating" inputs. PTB0 can be mapped to TPM channel 0, or to ADC channel 3.</p> |
| PTA3 | 14 | PTA3 / KBI3 / MOSI | <p>The PTA[3] pin is a general-purpose I/O pin. The pulldown devices can only be activated if the wake-up interrupt capability is enabled. User software must configure the general-purpose I/O pins so that they do not result in "floating" inputs. PTA[3] maps to keyboard interrupt function bit [3]. When SPI is enabled, PTA[3] serves as MOSI.</p> |
| PTA2 | 15 | PTA2 / KBI2 / MISO | <p>The PTA[2] pin is a general-purpose I/O pin. The pulldown devices can only be activated if the wake-up interrupt capability is enabled. User software must configure the general-purpose I/O pins so that they do not result in "floating" inputs. PTA[2] maps to keyboard interrupt function bit [2]. When SPI is enabled, PTA[2] serves as MISO.</p> |
| PTA1 | 16 | PTA1 / KBI1 / SCLK | <p>The PTA[1] pin is a general-purpose I/O pin. The pulldown devices can only be activated if the wake-up interrupt capability is enabled. User software must configure the general-purpose I/O pins so that they do not result in</p> |

Table 3. Pin description...continued

| Symbol | Pin | Function | Description |
|--------|-----|--------------------------|---|
| | | | “floating” inputs. PTA[1] maps to keyboard interrupt function bit [1]. When SPI is enabled, PTA[1] serves as SCLK |
| RFGND | 17 | RF ground | Power in the RF output amplifier is returned to the supply through the RFGND pin. This conductor should be connected to the power supply using a “star” connection such that each metal trace does not share any load currents with other supply pins. |
| RFOUT | 18 | RF output | The RFOUT pin is the RF energy data supplied by the unit to an external antenna. |
| PTA0 | 19 | PTA0 / KBI0 / SS_B / IRQ | The PTA[0] pin is a general-purpose I/O pin. PTA[0] can be configured as a normal bidirectional I/O pin with programmable pullup or pulldown devices and/or wake-up interrupt capability. PTA[0] can be configured for external interrupt (IRQ). The pulldown devices can only be activated if the wake-up interrupt capability is enabled. User software must configure the general-purpose I/O pins so that they do not result in “floating” inputs. PTA[0] maps to keyboard interrupt function bit [0]. When SPI is enabled, PTA0 serves as SS_B. |
| X1 | 20 | RF crystal input | The X1 pin is for an external 26 MHz crystal to be used by the internal PLL for creating the carrier frequencies and data rates for the RF pin. |
| X0 | 21 | RF crystal output | The X0 pin is for an external 26 MHz crystal to be used by the internal PLL for creating the carrier frequencies and data rates for the RF pin. |
| PTB1 | 22 | PTB1 / TPMCH1 / AD4 | The PTB[1] pin is a general-purpose I/O pin. This pin can be configured as a nominal bidirectional I/O pin with programmable pullup devices. User software must configure the general-purpose I/O pins (PTB[1:0]) so that they do not result in “floating” inputs. PTB1 can be mapped to TPM channel 1, or to ADC channel 4. |
| LFB | 23 | LF input '-' | <p>The LF[A:B] pins can be used by the LF receiver (LFR) as one differential input channel for sensing low-level signals from an external low frequency (LF) coil. The external LF coil should be connected between the LF[A] and the LF[B] pins.</p> <p>Signaling into the LFR pins can place the unit into various diagnostic or operational modes. The LFR is comprised of the detector and the decoder. Each LF[A:B] pin always has an impedance of approximately 500 kΩ to GND due to the LFR input circuitry.</p> <p>The LFA/LFB pins are used by the LFR when the LFEN control bit is set and are not functional when the LFEN control bit is clear.</p> |
| LFA | 24 | LF input '+' | <p>The LF[A:B] pins can be used by the LF receiver (LFR) as one differential input channel for sensing low-level signals from an external low frequency (LF) coil. The external LF coil should be connected between the LF[A] and the LF[B] pins.</p> <p>Signaling into the LFR pins can place the unit into various diagnostic or operational modes. The LFR is comprised of the detector and the decoder. Each LF[A:B] pin always has an impedance of approximately 500 kΩ to GND due to the LFR input circuitry.</p> <p>The LFA/LFB pins are used by the LFR when the LFEN control bit is set and are not functional when the LFEN control bit is clear.</p> |

5.3 Orientation

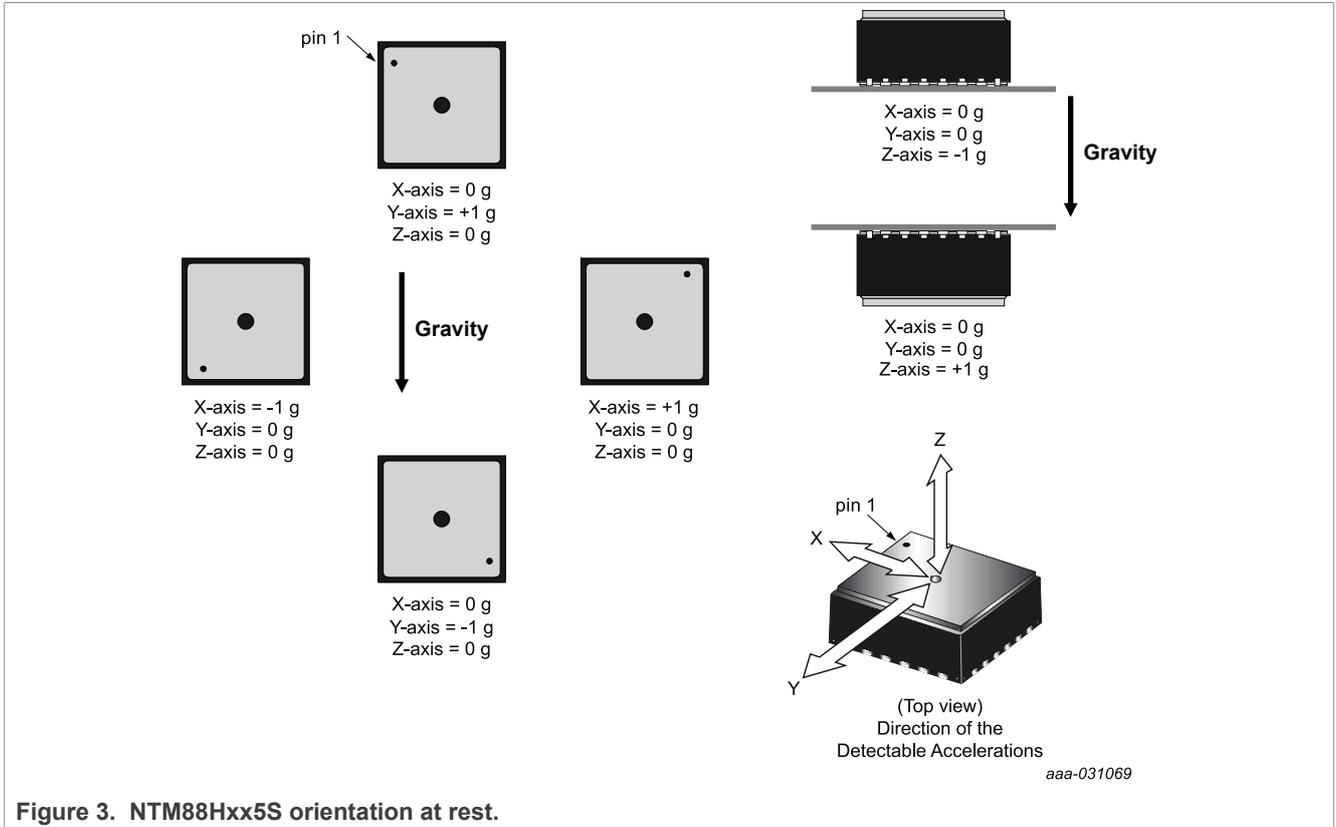

6 Electrical specifications

Tables in the electrical and mechanical specification sections of this data sheet may contain hyperlinked note references in the last cell of the row. The hyperlinks are linked to and defined in [Table 4](#).

Table 4. Electrical and mechanical specification note definition table

| Note identifier | Description |
|-----------------|---|
| A | Parameters tested 100 % at final test. |
| B | Parameters tested 100 % at unit probe. |
| C | Verified by characterization, not tested in production. |
| D | For information only, may be determined by simulation. |

6.1 Maximum ratings (electrical)

Maximum ratings are the extreme limits the device can be exposed to without permanently damaging it. The device contains circuitry to protect the inputs against damage from high static voltages; however, do not apply voltages higher than the values shown in [Table 5](#). Keep V_{IN} and V_{OUT} within the range $V_{SS} \leq (V_{IN} \text{ or } V_{OUT}) \leq V_{DD}$.

In all cases of transient environment, the sensor functional behaviors, parametric behaviors, and dimensions may deviate from the listed steady-state environment tolerances as compared to external reference(s). τ is the characteristic thermal time constant, from device case ambient to the on-die temperature transducer. Transient

environment means less than $2.3 \times \tau$ seconds since the last step-function transient of a condition; pressure, motion, temperature, supply voltage, electro-magnetic, humidity, vapor, media. Steady-state environment means $2.3 \times \tau$ or more seconds of stable conditions; pressure, motion, temperature, supply voltage, electro-magnetic, humidity, vapor, media. Examples of step-function transient condition might be tire blow-out, drop impact, ice-bath submersion, battery connection 'bounce', nearby radio transmitter, and so forth.

Table 5. Maximum ratings

| Symbol | Parameter | Conditions | Min | Typ | Max | Unit | Notes |
|--------------------|---|--|-----------------------|-----|-----------------------|------|-------------------|
| V _{DD} | V _{DD} or V _{DDA} to V _{SS} | T _L ≤ T _A ≤ T _H | -0.3 | — | 3.6 | V | C |
| V _{IO} | IO pin current, each pin vs V _{DD} / V _{DDA} or V _{SS} | T _{AS} Min ≤ T _A ≤ T _A Max | V _{SS} - 0.3 | — | V _{dd} + 0.3 | V | C |
| I _{IO} | IO pin current, pin vs V _{DD} / V _{DDA} or V _{SS} | T _L ≤ T _A ≤ T _H , V _{DDR} Min ≤ V _{DD} ≤ V _{DDR} Max | -10 | — | 10 | mA | C |
| I _{SUBIO} | Substrate current injection, all IO pins except LFA LFB current from pin to V _{SS} - 0.3 V | T _L ≤ T _A ≤ T _H , V _{DDR} Min ≤ V _{DD} ≤ V _{DDR} Max | — | 600 | — | μA | C |
| I _{SUBLF} | Substrate current injection, LFA LFB current from pin to V _{SS} - 0.3 V | T _L ≤ T _A ≤ T _H , V _{DDF} Min ≤ V _{DD} ≤ V _{DDF} Max | — | 2 | — | mA | C |
| I _{LATCH} | Latch-up current, current to/from pin to V _{DD} / V _{DDA} + 0.3 V | T _L ≤ T _A ≤ T _H , V _{DDR} Min ≤ V _{DD} ≤ V _{DDR} Max | -100 | — | 100 | mA | C |
| ESD _{HBM} | Electrostatic discharge, human body model (HBM), all pins except RF, and LF | T _A = 25 °C, V _{DD} = 3.0 V | -2000 | — | 2000 | V | C |
| ESD _{HBM} | Electrostatic discharge, human body model (HBM), RF, and LF | T _A = 25 °C, V _{DD} = 3.0 V | -2000 | — | 2000 | V | C |
| ESD _{CDM} | Electrostatic discharge, charged device model (CDM), all pins | T _A = 25 °C, V _{DD} = 3.0 V | -500 | — | 500 | V | C |
| T _{STG} | Unpowered storage, temperature range | — | -50 | — | 150 | °C | C |

6.2 Operating conditions

The limits normally expected in the application that define the range of operation.

Table 6. Operating range

| Symbol | Parameter | Conditions | Min | Typ | Max | Unit | Notes |
|------------------|--|---|--------------------|-----|-----|------|-------------------|
| V _{DDR} | Operating voltage range, Parameter register retention where Min = V _L , Typ = 3.0 V, Max = V _H | T _{AS} Min ≤ T _A ≤ T _{AS} Max | 1.2 | 3.0 | 3.6 | V | C |
| V _{DDS} | Operating voltage range, MCU and SW, Flash Read, RF TX, Voltage Measurement where Min = V _L , Typ = 3.0 V, Max = V _H | T _{AS} Min ≤ T _A ≤ T _{AS} Max | V _{LVDRF} | 3.0 | 3.6 | V | C |
| V _{DDM} | Operating voltage range, Pressure, Temperature and Acceleration Measurements where Min = V _L , Typ = 3.0 V, Max = V _H | T _{AS} Min ≤ T _A ≤ T _{AS} Max | 2.1 | 3.0 | 3.6 | V | C |
| V _{DDF} | Operating voltage range, Flash Programming and LF RX, where Min = V _L , Typ = 3.0 V, Max = V _H | -20 °C ≤ T _A ≤ 85 °C | 2.1 | 3.0 | 3.6 | V | C |
| T _{AS} | Operating temperature range, Full functionality except LF RX, and Flash Programming where Min = T _L , Typ = 25 °C, Max = T _H | V _{DDS} Min ≤ V _{DD} ≤ V _{DDS} Max | -40 | 25 | 125 | °C | C |

Table 6. Operating range...continued

| Symbol | Parameter | Conditions | Min | Typ | Max | Unit | Notes |
|--------------------------------------|--|---|-----|------|------|------|-------------------|
| T _{AF} | Operating temperature range, Operating voltage range, Full functionality, including LF RX, and Flash programming | V _{DDF} Min ≤ V _{DD} ≤ V _{DDF} Max | -20 | 25 | 85 | °C | C |
| T _{A-EXC} | Operating temperature range excursion; 12 excursions of 15 minutes ea. (all Tolerances may be out of spec) | V _{DDM} Min ≤ V _{DD} ≤ V _{DDM} Max | — | — | 150 | °C | C |
| I _{DD1} | Supply Current; Stop1 Mode (only LFO, PWU, and param. reg. On) | Typ = 25 °C, 3.0 V, Max = T _{AS} Min to Max & V _{DDR} Min to Max | — | 0.18 | 18 | µA | B |
| I _{DD4} | Supply Current; Stop4 Mode (only MCU, RF, and LF disabled) | Typ = 25 °C, 3.0 V, Max = T _{AS} Min to Max & V _{DDS} Min to Max | — | 75 | 125 | µA | B |
| I _{DDLFS} | Supply Current; Standby LF sniff (and Stop1 equivalent) | Typ = 25 °C, 3.0 V, Max = T _{AF} Min to Max & V _{DDF} Min to Max | — | 4.8 | 8.1 | µA | C |
| I _{DDLFD} | Supply Current; Standby LF Decoding (and Stop1 equivalent) | Typ = 25 °C, 3.0 V, Max = T _{AF} Min to Max & V _{DDF} Min to Max | — | 11.3 | 14.3 | µA | C |
| I _{DDR5K} | Supply Current; MCU Run 500 kHz (and RF and LF disabled) | Typ = 25 °C, 3.0 V, Max = T _{AS} Min to Max & V _{DDS} Min to Max | — | 0.8 | 1.0 | mA | C |
| I _{DDR1M} | Supply Current; MCU Run 1 MHz (and RF and LF disabled) | Typ = 25 °C, 3.0 V, Max = T _{AS} Min to Max & V _{DDS} Min to Max | — | 1.0 | 1.2 | mA | C |
| I _{DDR2M} | Supply Current; MCU Run 2 MHz (and RF and LF disabled) | Typ = 25 °C, 3.0 V, Max = T _{AS} Min to Max & V _{DDS} Min to Max | — | 1.42 | 1.6 | mA | C |
| I _{DDR4M} | Supply Current; MCU Run 4 MHz (and RF and LF disabled) | Typ = 25 °C, 3.0 V, Max = T _{AS} Min to Max & V _{DDS} Min to Max | — | 2.1 | 2.5 | mA | B |
| I _{DDRFT3} | Supply Current; RF TX 5 dBm, 315 MHz (and Stop1 equivalent) | T _A = 25 °C, V _{DD} = 3.0 V | — | 5.7 | 6.1 | mA | B |
| I _{DDRFT4} | Supply Current; RF TX 5 dBm, 434 MHz (and Stop1 equivalent) | T _A = 25 °C, V _{DD} = 3.0 V | — | 6.3 | 6.8 | mA | B |
| I _{DDRFTX1} | Supply Current Increase w/ BOOST = 1 RF TX 5 dBm (and Stop1 equivalent) | T _A = 25 °C, V _{DD} = 3.0 V | — | — | 0.6 | mA | C |
| I _{DDIF0} | Supply Current, RF Interframe period, IFPD = 0 | Typ = 25 °C, 3.0 V, Max = T _{AS} Min to Max & V _{DDS} Min to Max | — | 610 | 870 | µA | C |
| I _{DDIF1} | Supply Current, RF Interframe period, IFPD = 1 | Typ = 25 °C, 3.0 V, Max = T _{AS} Min to Max & V _{DDS} Min to Max | — | 19 | 36 | µA | C |
| I _{DDA} or I _{DDP} | Supply Current Peak; Accel. or Pressure Measurements (and Stop4 equivalent) | Typ = 25 °C, 3.0 V, Max = T _{AS} Min to Max & V _{DDM} Min to Max | — | 2.8 | 3.15 | mA | C |
| I _{DDV} or I _{DDT} | Supply Current Peak; Voltage or Temp. Measurements (and Stop4 equivalent) | Typ = 25 °C, 3.0 V, Max = T _{AS} Min to Max & V _{DDM} Min to Max | — | 2.8 | 3.8 | mA | C |

6.3 Charge consumptions

Table 7. Charge consumptions

$T_L \leq T_A \leq T_H$, unless otherwise specified.

| Symbol | Parameter | Conditions | Min | Typ | Max | Unit | Notes |
|---------------|--|--|-----|------|-----|--------------|-------------------|
| Q_{wake} | Stop1 to run charge consumption, F_{bus} set for 4 MHz | $V_{DDM} Min \leq V_{DD} \leq V_{DDM} Max$ | — | 0.10 | — | μA -sec | C |
| QPA_{r512} | Pressure or accelerometer charge consumption; Raw 512 μs settling per sample | $V_{DDM} Min \leq V_{DD} \leq V_{DDM} Max$ | — | 0.95 | — | μA -sec | C |
| QPA_{r2048} | Pressure or accelerometer charge consumption; Raw 2048 μs settling per sample | $V_{DDM} Min \leq V_{DD} \leq V_{DDM} Max$ | — | 1.85 | — | μA -sec | C |
| QP_{c3} | Pressure charge consumption; Compensation third order per sample | $V_{DDM} Min \leq V_{DD} \leq V_{DDM} Max$ | — | 1.77 | — | μA -sec | D |
| QA_{c2} | Accelerometer charge consumption; Compensation second order per sample | $V_{DDM} Min \leq V_{DD} \leq V_{DDM} Max$ | — | 1.95 | — | μA -sec | D |
| QVT_{r50} | Voltage or temperature charge consumption; Raw 50 μs conversion per sample | $V_{DDM} Min \leq V_{DD} \leq V_{DDM} Max$ | — | 0.2 | — | μA -sec | C |
| QVT_{c250} | Voltage or temperature charge consumption; Compensation ~ 0.25 ms per sample | $V_{DDM} Min \leq V_{DD} \leq V_{DDM} Max$ | — | 0.50 | — | μA -sec | D |

6.4 Clocks and thresholds

Table 8. Clocks and thresholds

$V_{DDs} Min \leq V_{DD} \leq V_{DDs} Max$, $T_{AS} Min \leq T_A \leq T_{AS} Max$, unless otherwise specified.

| Symbol | Parameter | Conditions | Min | Typ | Max | Unit | Notes |
|-------------|--|--|------|-----|------|---------|-------------------|
| f_{BUS} | MCU bus frequency multiple of HFO | $V_{DD} > V_{LVDRF}$ | — | 0.5 | — | x HFO | D |
| f_{HFO} | High frequency oscillator, multiple of MFO | $V_{DD} > V_{LVDRF}$ | — | 64 | — | x MFO | D |
| t_{HFOST} | Stabilization time | — | — | 300 | 1000 | μs | D |
| f_{MFO} | Medium frequency oscillator | $V_{DD} > V_{LVDRF}$ | 107 | 125 | 135 | kHz | A |
| f_{LFO} | Low frequency oscillator | — | 504 | — | 1512 | Hz | B |
| f_{LFRO} | LFR Clock (derived from LFRO) | — | 120 | 129 | 139 | kHz | B |
| t_{STOP1} | MCU wake-up time | From Stop1 to 1 st instruction, 4 MHz | — | 50 | 70 | μs | C |
| t_{STOP4} | MCU wake-up time | From Stop4 to 1 st instruction, 4 MHz | — | 25 | 35 | μs | C |
| t_{LV} | Low voltage times | $V_{DD} < V_{LVx}$ | — | — | 10 | μs | D |
| V_{LVWLF} | Low voltage warning (LVW) | Lower threshold, V_{DD} falling | 1.95 | — | 2.2 | V | C |
| V_{LVWLR} | Low voltage warning (LVW) | Lower threshold, V_{DD} rising | 2.02 | — | 2.1 | V | C |
| V_{LVWHF} | Low voltage warning (LVW) | Higher threshold, V_{DD} falling | 2.28 | — | 2.54 | V | C |
| V_{LVWHR} | Low voltage warning (LVW) | Higher threshold, V_{DD} rising | 2.34 | — | 2.61 | V | C |
| V_{LVDLF} | Low voltage detection (LVD) | Lower threshold, V_{DD} falling | 1.79 | — | 1.96 | V | C |
| V_{LVDLR} | Low voltage detection (LVD) | Lower threshold, V_{DD} rising | 1.87 | — | 2.03 | V | C |

Table 8. Clocks and thresholds...continued

$V_{DDs\ Min} \leq V_{DD} \leq V_{DDs\ Max}$, $T_{AS\ Min} \leq T_A \leq T_{AS\ Max}$, unless otherwise specified.

| Symbol | Parameter | Conditions | Min | Typ | Max | Unit | Notes |
|--------------------|-----------------------------|---|------|-----|-----|------|-------------------|
| V _{LVDHF} | Low voltage detection (LVD) | Higher threshold, V _{DD} falling | 1.95 | — | 2.2 | V | C |
| V _{LVDHR} | Low voltage detection (LVD) | Higher threshold, V _{DD} rising | 2.02 | — | 2.1 | V | C |
| V _{LVDRF} | RF LVD | V _{DD} falling | 1.6 | — | 2.1 | V | C |
| T _{FDR} | Flash memory data retention | — | 10 | — | — | Yr | D |

6.5 Power-on reset operation

When power is initially applied to the device, or when the supply voltage drops below the V_{POR} level, the POR circuit causes a reset condition. As the supply voltage rises, the LVD circuit holds the chip in reset until the supply has risen above the level determined by LVDV bit. Both the POR bit and the LVD bit in SRS are set following a POR.

Table 9. Power-on reset

$V_{DDs\ Min} \leq V_{DD} \leq V_{DDs\ Max}$, $T_{AS\ Min} \leq T_A \leq T_{AS\ Max}$, unless otherwise specified.

| Symbol | Parameter | Conditions | Min | Typ | Max | Unit | Notes |
|-------------------|----------------------|--|-----|-----|-----|------|-------------------|
| t _R | Power on reset (POR) | V _{DD} risetime to avoid latch up | — | — | 1 | s | C |
| t _{POR} | Power on reset (POR) | Time for V _{DD} < 0.5 V to assure POR | 70 | — | — | µs | C |
| V _{PORR} | Power on reset (POR) | Rising voltage to release reset | — | — | 2.1 | V | C |
| V _{PORA} | Power on reset (POR) | Falling voltage to assert reset | 0.8 | — | — | V | C |

6.6 GPIO port pins

Table 10. GPIO port pins

$V_{DDs\ Min} \leq V_{DD} \leq V_{DDs\ Max}$, $T_{AS\ Min} \leq T_A \leq T_{AS\ Max}$, unless otherwise specified.

| Symbol | Parameter | Conditions | Min | Typ | Max | Unit | Notes |
|--------------------|----------------------------|---|---|-----|---|------|-------------------|
| V _{OH} | Output high voltage | I _{LOAD} = 5 mA | V _{DD} - 0.35 | — | — | V | D |
| V _{OL} | Output low voltage | I _{LOAD} = 5 mA | — | — | V _{SS} + 0.35 | V | D |
| V _{IHn} | Input high voltage | 2.3 V ≤ V _{DD} ≤ V _H , T _A = T _L , T _H | 0.7 × V _{DD} / V _{DDA} | — | V _{DD} / V _{DDA} | V | D |
| V _{IHv} | Input high voltage | V _{DD} ≤ 2.3 V, T _A = 25 °C | 0.85 × V _{DD} / V _{DDA} | — | V _{DD} / V _{DDA} | V | D |
| V _{ILn} | Input low voltage | 2.3 V ≤ V _{DD} ≤ V _H , T _A = T _L , T _H | V _{SS} | — | 0.35 × V _{DD} / V _{DDA} | V | D |
| V _{ILv} | Input low voltage | V _{DD} ≤ 2.3 V, T _A = 25 °C | V _{SS} | — | 0.28 × V _{DD} / V _{DDA} | V | D |
| I _{IH} | Input high current, PTA0:3 | Pulldown disabled; V _{IH} Min | -1 | — | +1 | µA | D |
| I _{IHp} | Input high current, PTA0:3 | Pulldown enabled; V _{IH} Min | 0 | — | 120 | µA | D |
| I _{IL} | Input low current, PTA0:3 | Pullup disabled; V _{IL} Max | -1 | — | +1 | µA | D |
| I _{ILp} | Input low current, PTA0:3 | Pullup enabled; V _{IL} Max | -120 | — | 0 | µA | D |
| I _{IH-IL} | Input current PTA4 only | V _{IH} Min and V _{IL} Max | -120 | — | 120 | µA | D |

Table 10. GPIO port pins...continued

$V_{DDS\ Min} \leq V_{DD} \leq V_{DDS\ Max}$, $T_{AS\ Min} \leq T_A \leq T_{AS\ Max}$, unless otherwise specified.

| Symbol | Parameter | Conditions | Min | Typ | Max | Unit | Notes |
|-------------------|-----------------------|-------------------------|-----|-----|-----|------|-------------------|
| C _{IO} | Pin capacitance | V _{DD} = 3.0 V | 0 | — | 15 | pF | D |
| C _{MISO} | MISO load capacitance | V _{DD} = 3.0 V | — | — | 50 | pF | D |

6.7 SPI timing characteristics

Table 11. SPI timing

$V_{DDS\ Min} \leq V_{DD} \leq V_{DDS\ Max}$, $T_{AS\ Min} \leq T_A \leq T_{AS\ Max}$, unless otherwise specified.

| Symbol | Parameter | Conditions | Min | Typ | Max | Unit | Notes |
|-----------------------|--|------------|-----|-----|-----|-------------------------|-------------------|
| t _{SSMIN} | SS_B asserted period | — | 1 | — | — | f _{BUS} period | D |
| t _{ACCESS} | SS_B low to MISO | — | — | — | 50 | ns | D |
| t _{LEAD} | SS_B low to SCLK start | — | 50 | — | — | ns | D |
| t _{SETUP} | MOSI to SCLK start | — | 20 | — | — | ns | D |
| t _{SCLK} | SCLK period | — | 100 | — | — | ns | D |
| t _{SCLKH} | SCLK high portion | — | 35 | — | — | ns | D |
| t _{SCLKL} | SCLK low portion | — | 35 | — | — | ns | D |
| t _{SCLKR} | SCLK risetime | — | — | 10 | 25 | ns | D |
| t _{SCLKF} | SCLK fall time | — | — | 10 | 25 | ns | D |
| t _{VALID} | MISO valid transition time | — | — | — | 30 | ns | D |
| t _{HOLD_IN} | MOSI hold time | — | 10 | — | — | ns | D |
| t _{HOLD_OUT} | SCLK high to MISO transition start | — | 0 | — | — | ns | D |
| t _{LAG} | Final SCLK low to SS_B high | — | 60 | — | — | ns | D |
| t _{DISABLE} | SS_B high to MISO 3-state | — | — | — | 60 | ns | D |
| t _{SS_REJ} | SS_B noise rejection period | — | — | — | 5 | ns | D |
| t _{SSCLK} | SS_B high to SCLK high | — | 50 | — | — | ns | D |
| t _{CLKSS} | SCLK high to SCLK low | — | 50 | — | — | ns | D |
| t _{SSN} | SS_B not asserted period | — | 6 | — | — | f _{BUS} period | D |
| t _{LEAD-WU} | Wake-up by SS_B low to SCLK start | — | 1 | — | — | ms | D |
| t _{SPI_EN} | SPI enable by SS_B low after V _{DD} > V _{PORR} | — | 200 | — | — | μs | D |

6.8 Temperature measurement characteristics

Table 12. Temperature measurement

$V_{DDM\ Min} \leq V_{DD} \leq V_{DDM\ Max}$, $T_{AS\ Min} \leq T_A \leq T_{AS\ Max}$, unless otherwise specified.

Transfer function: $T\ ^\circ\text{C} = (1\ ^\circ\text{C} / \text{LSB} \times T_{CODE}) - 55\ ^\circ\text{C}$

| Symbol | Parameter | Conditions | Min | Typ | Max | Unit | Notes |
|-----------------------|-------------|------------|------|-----|------|----------|-------------------|
| DT _{MAX-MIN} | Sensitivity | — | 0.93 | 1 | 1.08 | °C / LSB | C |
| T _{ERROR} | Error | — | — | 0 | — | LSB | C |
| T _{UNDER} | Underflow | — | — | 1 | — | LSB | C |

Table 12. Temperature measurement...continued

$V_{DDM} Min \leq V_{DD} \leq V_{DDM} Max$, $T_{AS} Min \leq T_A \leq T_{AS} Max$, unless otherwise specified.

Transfer function: $T \text{ } ^\circ\text{C} = (1 \text{ } ^\circ\text{C} / \text{LSB} \times T_{CODE}) - 55 \text{ } ^\circ\text{C}$

| Symbol | Parameter | Conditions | Min | Typ | Max | Unit | Notes |
|-----------------------|-------------------------------|--|-----|-----|-----|------|-------|
| T _{OVER} | Overflow | — | — | 255 | — | LSB | C |
| T _{MIN} | Temperature measurement | T _A = -50 °C | — | 5 | — | LSB | D |
| T _{RATE-MIN} | Temperature measurement | T _A = -40 °C | 11 | 15 | 19 | LSB | C |
| T _{CODE} | Temperature measurement | T _A = -20 °C | 32 | 35 | 38 | LSB | A |
| T _{CODE} | Temperature measurement | T _A = 0 °C | 52 | 55 | 58 | LSB | C |
| T _{CODE} | Temperature measurement | T _A = 25 °C | 77 | 80 | 83 | LSB | B |
| T _{CODE} | Temperature measurement | T _A = 70 °C | 122 | 125 | 128 | LSB | C |
| T _{CODE} | Temperature measurement | T _A = 85 °C | 137 | 140 | 143 | LSB | A |
| T _{CODE} | Temperature measurement | T _A = 105 °C | 156 | 160 | 164 | LSB | C |
| T _{RATE-MAX} | Temperature measurement | T _A = 125 °C | 175 | 180 | 185 | LSB | B |
| T _{MAX} | Temperature measurement | T _A = 150 °C ^[1] | — | 205 | — | LSB | D |
| T _{DRIFT} | Temperature measurement drift | — | -3 | — | +3 | LSB | C |

[1] Temperature excursions, time at T_{MAX} must not exceed 12 events of 15 minutes duration during the product lifetime.

6.9 Voltage measurement characteristics

Table 13. Voltage measurement characteristics

$V_{DDS} Min \leq V_{DD} \leq V_{DDS} Max$, $T_{AS} Min \leq T_A \leq T_{AS} Max$, unless otherwise specified.

Transfer function: $V = (0.01 \text{ V} / \text{LSB} \times V_{CODE}) + 1.22 \text{ V}$

Interpolated limits between -40 °C to 0 °C and between 50 °C to 125 °C.

| Symbol | Parameter | Conditions | Min | Typ | Max | Unit | Notes |
|-----------------------|--------------------------------|--|-----|-----|-----|----------|-------|
| DV _{MAX-MIN} | Sensitivity | — | 9 | 10 | 12 | mV / LSB | C |
| V _{ERROR} | Error | — | — | 0 | — | LSB | C |
| V _{UNDER} | Underflow | — | — | 1 | — | LSB | C |
| V _{OVER} | Overflow | — | — | 255 | — | LSB | C |
| V _{CODE} | V _{DD} voltage, 2.8 V | 0 °C ≤ T _A ≤ 50 °C, V _{DD} = 2.8 V | 153 | 158 | 163 | LSB | C |
| V _{CODE} | V _{DD} voltage, 3.0 V | 0 °C ≤ T _A ≤ 50 °C, V _{DD} = 3.0 V | 173 | 178 | 183 | LSB | C |
| V _{CODE} | V _{DD} voltage, 3.3 V | 0 °C ≤ T _A ≤ 50 °C, V _{DD} = 3.3 V | 203 | 208 | 213 | LSB | C |
| V _{MIN} | V _{DD} voltage, 1.8 V | — | 38 | 58 | 78 | LSB | C |
| V _{CODE} | V _{DD} voltage, 2.1 V | — | 68 | 88 | 108 | LSB | B |
| V _{CODE} | V _{DD} voltage, 2.3 V | -40 °C ≤ T _A ≤ 0 °C or 50 °C ≤ T _A ≤ 125 °C, V _{DD} = 2.3 V | 98 | 108 | 118 | LSB | C |
| V _{CODE} | V _{DD} voltage, 2.8 V | -40 °C ≤ T _A ≤ 0 °C or 50 °C ≤ T _A ≤ 125 °C, V _{DD} = 2.8 V | 148 | 158 | 168 | LSB | C |
| V _{CODE} | V _{DD} voltage, 3.0 V | -40 °C ≤ T _A ≤ 0 °C or 50 °C ≤ T _A ≤ 125 °C, V _{DD} = 3.0 V | 168 | 178 | 188 | LSB | B |
| V _{CODE} | V _{DD} voltage, 3.3 V | -40 °C ≤ T _A ≤ 0 °C or 50 °C ≤ T _A ≤ 125 °C, V _{DD} = 3.3 V | 198 | 208 | 218 | LSB | C |
| V _{MAX} | V _{DD} voltage, 3.6 V | — | 228 | 238 | 248 | LSB | C |
| V _{DRIFT} | Voltage drift | — | -3 | — | +3 | LSB | C |

Table 14. External pin voltage measurement

$V_{DDs\ Min} \leq V_{DD} \leq V_{DDs\ Max}$, $T_{AS\ Min} \leq T_A \leq T_{AS\ Max}$, unless otherwise specified.

Transfer function: $V = (V_{DD} V / LSB \times GxCODE) / 1023$, where $x = 0$ for PTB0, 1 for PTB1

| Symbol | Parameter | Conditions | Min | Typ | Max | Unit | Notes |
|--------------------|--------------------------------------|---------------|-----|-----------------|-----|---------|-------|
| $\Delta GxMAX-MIN$ | Sensitivity | — | — | $V_{dd} / 1023$ | — | V / LSB | C |
| GxERROR | Error | Status = \$01 | — | 0 | — | LSB | C |
| GxCODE | Voltage measurement, $V = 0\ V$ | Status = \$00 | — | 0 | — | LSB | C |
| GxCODE | Voltage measurement, $V = V_{DD}\ V$ | — | — | 1023 | — | LSB | C |
| GxDRIFT | Voltage measurement drift | — | -1 | — | +1 | LSB | C |

6.10 Pressure measurement characteristics

Unless otherwise noted, stated tolerances are valid only with Initial Sample Delay [ISD3:0] set for > 2.5 ms and MCU placed in STOP4 mode.

6.10.1 Pressure measurement characteristic (90 kPa to 930 kPa) range

Table 15. Pressure measurement characteristics (90 kPa to 930 kPa) range

$V_{DDM\ Min} \leq V_{DD} \leq V_{DDM\ Max}$, $T_{AS\ Min} \leq T_A \leq T_{AS\ Max}$, unless otherwise specified.

Transfer function: $P\ kPa = (0.824\ kPa / LSB \times P_{CODE}) + 88.353\ kPa$

Interpolated limits between 105 °C and 125 °C.

| Symbol | Parameter | Conditions | Min | Typ | Max | Unit | Notes |
|----------------|-------------------------|---|------|-------|------|-----------|-------|
| $DP_{MAX-MIN}$ | Sensitivity | — | 0.78 | 0.824 | 0.86 | kPa / LSB | C |
| P_{ERROR} | Error | — | — | 0 | — | LSB | C |
| P_{UNDER} | Underflow | FW error status bit 0 = 1 | — | 1 | — | LSB | C |
| P_{OVER} | Overflow | FW error status bit 0 = 1 | — | 1023 | — | LSB | C |
| P_{MIN} | Proof pressure, 90 kPa | $-40\ ^\circ C \leq T_A \leq 105\ ^\circ C$ | — | 2 | 11 | LSB | D |
| P_{CODE} | Proof pressure, 230 kPa | $-40\ ^\circ C \leq T_A \leq 105\ ^\circ C$ | 166 | 172 | 178 | LSB | C |
| P_{CODE} | Proof pressure, 370 kPa | $-40\ ^\circ C \leq T_A \leq 105\ ^\circ C$ | 336 | 342 | 348 | LSB | A |
| P_{CODE} | Proof pressure, 510 kPa | $-40\ ^\circ C \leq T_A \leq 105\ ^\circ C$ | 506 | 512 | 518 | LSB | C |
| P_{CODE} | Proof pressure, 650 kPa | $-40\ ^\circ C \leq T_A \leq 105\ ^\circ C$ | 676 | 682 | 688 | LSB | C |
| P_{CODE} | Proof pressure, 790 kPa | $-40\ ^\circ C \leq T_A \leq 105\ ^\circ C$ | 846 | 852 | 858 | LSB | A |
| P_{MAX} | Proof pressure, 930 kPa | $-40\ ^\circ C \leq T_A \leq 105\ ^\circ C$ | 1016 | 1022 | — | LSB | D |
| P_{MIN} | Proof pressure, 90 kPa | $T_A = 125\ ^\circ C$ | — | 2 | 22 | LSB | D |
| P_{CODE} | Proof pressure, 230 kPa | $T_A = 125\ ^\circ C$ | 151 | 172 | 192 | LSB | C |
| P_{CODE} | Proof pressure, 370 kPa | $T_A = 125\ ^\circ C$ | 322 | 342 | 362 | LSB | C |
| P_{CODE} | Proof pressure, 510 kPa | $T_A = 125\ ^\circ C$ | 492 | 512 | 532 | LSB | C |
| P_{CODE} | Proof pressure, 650 kPa | $T_A = 125\ ^\circ C$ | 662 | 682 | 702 | LSB | C |
| P_{CODE} | Proof pressure, 790 kPa | $T_A = 125\ ^\circ C$ | 832 | 852 | 872 | LSB | C |
| P_{MAX} | Proof pressure, 930 kPa | $T_A = 125\ ^\circ C$ | 1002 | 1022 | — | LSB | D |
| P_{DRIFT} | Pressure drift | — | — | — | ±6 | LSB | C |

6.11 Acceleration measurement characteristics

Unless otherwise noted, stated tolerances are valid only with Initial Sample Delay [ISD3:0] set for > 2.5 ms and MCU placed in STOP4 mode.

6.11.1 Acceleration measurement characteristics (–80 g to +90 g) range option

Table 16. Acceleration measurement characteristic (–80 g to +90 g) range option

$V_{DDs\ Min} \leq V_{DD} \leq V_{DDs\ Max}$, $T_{AS\ Min} \leq T_A \leq T_{AS\ Max}$, unless otherwise specified.

Transfer Function: Offset Step 7 $A\ g's = (0.020\ g/LSB \times A_{CODE}) - 10.039\ g$

Interpolated limits between –40 °C to –20 °C and between 85 °C to 125 °C

| Symbol | Parameter | Conditions | Min | Typ | Max | Unit | Notes |
|----------------|--|--|-------|-------|-------|---------|-------|
| $DA_{MAX-MIN}$ | Sensitivity | — | 0.014 | 0.020 | 0.034 | g / LSB | C |
| A_{ERROR} | Error | — | — | 0 | — | LSB | C |
| A_{UNDER} | Underflow | FW error status bit 0 = 1 | — | 1 | — | LSB | C |
| A_{OVER} | Overflow | FW error status bit 0 = 1 | — | 1023 | — | LSB | C |
| A_{MIN0} | Acceleration measurement, –80 g, Offset step 0 | $-20\ ^\circ C \leq T_A \leq 85\ ^\circ C$ | — | 2 | — | LSB | D |
| A_{CODE0} | Acceleration measurement, –75 g, Offset Step 0 | $-20\ ^\circ C \leq T_A \leq 85\ ^\circ C$ | — | 257 | — | LSB | D |
| A_{CODE0} | Acceleration measurement, –70 g, Offset Step 0 | $-20\ ^\circ C \leq T_A \leq 85\ ^\circ C$ | — | 512 | — | LSB | D |
| A_{CODE0} | Acceleration measurement, –65 g, Offset Step 0 | $-20\ ^\circ C \leq T_A \leq 85\ ^\circ C$ | — | 767 | — | LSB | D |
| A_{MAX0} | Acceleration measurement, –60 g, Offset Step 0 | $-20\ ^\circ C \leq T_A \leq 85\ ^\circ C$ | — | 1022 | — | LSB | D |
| A_{MIN7} | Acceleration measurement, –10 g, Offset Step 7 | $-20\ ^\circ C \leq T_A \leq 85\ ^\circ C$ | — | 2 | 180 | LSB | D |
| A_{CODE7} | Acceleration measurement, –5 g, Offset Step 7 | $-20\ ^\circ C \leq T_A \leq 85\ ^\circ C$ | 104 | 257 | 410 | LSB | D |
| A_{CODE7} | Acceleration measurement, 0 g, Offset Step 7 | $-20\ ^\circ C \leq T_A \leq 85\ ^\circ C$ | 384 | 512 | 640 | LSB | A |
| A_{CODE7} | Acceleration measurement, 5 g, Offset Step 7 | $-20\ ^\circ C \leq T_A \leq 85\ ^\circ C$ | 614 | 767 | 920 | LSB | D |
| A_{MAX7} | Acceleration measurement, 10 g, Offset Step 7 | $-20\ ^\circ C \leq T_A \leq 85\ ^\circ C$ | 844 | 1022 | — | LSB | D |
| A_{MIN7} | Acceleration measurement, –10 g, Offset Step 7 | $T_A = -40\ ^\circ C$ and $125\ ^\circ C$ | — | 2 | 216 | LSB | D |
| A_{CODE7} | Acceleration measurement, –5 g, Offset Step 7 | $T_A = -40\ ^\circ C$ and $125\ ^\circ C$ | 73 | 257 | 441 | LSB | D |
| A_{CODE7} | Acceleration measurement, 0 g, Offset Step 7 | $T_A = -40\ ^\circ C$ and $125\ ^\circ C$ | 359 | 512 | 665 | LSB | D |
| A_{CODE7} | Acceleration measurement, 5 g, Offset Step 7 | $T_A = -40\ ^\circ C$ and $125\ ^\circ C$ | 583 | 767 | 951 | LSB | D |
| A_{MAX7} | Acceleration measurement, 10 g, Offset Step 7 | $T_A = -40\ ^\circ C$ and $125\ ^\circ C$ | 808 | 1022 | — | LSB | D |
| A_{MIN15} | Acceleration measurement, 70 g, Offset Step 15 | $-20\ ^\circ C \leq T_A \leq 85\ ^\circ C$ | — | 2 | — | LSB | D |
| A_{CODE15} | Acceleration measurement, 75 g, Offset Step 15 | $-20\ ^\circ C \leq T_A \leq 85\ ^\circ C$ | — | 257 | — | LSB | D |

Table 16. Acceleration measurement characteristic (–80 g to +90 g) range option...continued

$V_{DD5} Min \leq V_{DD} \leq V_{DD5} Max$, $T_{AS} Min \leq T_A \leq T_{AS} Max$, unless otherwise specified.

Transfer Function: Offset Step 7 $A\ g's = (0.020\ g/LSB \times A_{CODE}) - 10.039\ g$

Interpolated limits between –40 °C to –20 °C and between 85 °C to 125 °C

| Symbol | Parameter | Conditions | Min | Typ | Max | Unit | Notes |
|---------------------|--|---------------------------------|-----|------|-----|------|-------|
| A _{CODE15} | Acceleration measurement, 80 g, Offset Step 15 | –20 °C ≤ T _A ≤ 85 °C | — | 512 | — | LSB | D |
| A _{CODE15} | Acceleration measurement, 85 g, Offset Step 15 | –20 °C ≤ T _A ≤ 85 °C | — | 767 | — | LSB | D |
| A _{MAX15} | Acceleration measurement, 90 g, Offset Step 15 | –20 °C ≤ T _A ≤ 85 °C | — | 1022 | — | LSB | D |
| A _{DRIFT} | Inertia drift | — | –5 | — | +5 | LSB | C |

6.11.2 Acceleration measurement characteristic (–360 g to +400 g) range option

Table 17. Acceleration measurement characteristic (–360 g to +400 g) range option

$V_{DDM} Min \leq V_{DD} \leq V_{DDM} Max$, $T_{AS} Min \leq T_A \leq T_{AS} Max$, unless otherwise specified.

Transfer Function: Offset Step 7 $A\ g's = (0.088\ g/LSB \times A_{CODE}) - 45.176\ g$

Interpolated limits between –40 °C to –20 °C and between 85 °C to 125 °C

| Symbol | Parameter | Conditions | Min | Typ | Max | Unit | Notes |
|-------------------------|--|------------------------------------|-------|-------|-------|---------|-------|
| DdrA _{MAX-MIN} | Sensitivity | — | 0.074 | 0.088 | 0.108 | g / LSB | C |
| A _{ERROR} | Error | — | — | 0 | — | LSB | C |
| A _{UNDER} | Underflow | FW error status bit 0 = 1 | — | 1 | — | LSB | C |
| A _{OVER} | Overflow | FW error status bit 0 = 1 | — | 1023 | — | LSB | C |
| A _{MIN0} | Acceleration measurement, –360 g, Offset step 0 | –20 °C ≤ T _A ≤ 85 °C | — | 2 | — | LSB | D |
| A _{CODE0} | Acceleration measurement, –338 g, Offset step 0 | –20 °C ≤ T _A ≤ 85 °C | — | 257 | — | LSB | D |
| A _{CODE0} | Acceleration measurement, –315 g, Offset step 0 | –20 °C ≤ T _A ≤ 85 °C | — | 512 | — | LSB | D |
| A _{CODE0} | Acceleration measurement, –293 g, Offset step 0 | –20 °C ≤ T _A ≤ 85 °C | — | 767 | — | LSB | D |
| A _{MAX0} | Acceleration measurement, –270 g, Offset step 0 | –20 °C ≤ T _A ≤ 85 °C | — | 1022 | — | LSB | D |
| A _{MIN7} | Acceleration measurement, –45 g, Offset step 7 | –20 °C ≤ T _A ≤ 85 °C | — | 2 | 81 | LSB | D |
| A _{CODE7} | Acceleration measurement, –22.5 g, Offset step 7 | –20 °C ≤ T _A ≤ 85 °C | 203 | 257 | 311 | LSB | D |
| A _{CODE7} | Acceleration measurement, 0 g, Offset step 7 | –20 °C ≤ T _A ≤ 85 °C | 483 | 512 | 541 | LSB | A |
| A _{CODE7} | Acceleration measurement, 22.5 g, Offset step 7 | –20 °C ≤ T _A ≤ 85 °C | 713 | 767 | 821 | LSB | D |
| A _{MAX7} | Acceleration measurement, 45 g, Offset step 7 | –20 °C ≤ T _A ≤ 85 °C | 943 | 1022 | — | LSB | D |
| A _{MIN7} | Acceleration measurement, –45 g, Offset step 7 | T _A = –40 °C and 125 °C | — | 2 | 97 | LSB | D |
| A _{CODE7} | Acceleration measurement, –22.5 g, Offset step 7 | T _A = –40 °C and 125 °C | 192 | 257 | 322 | LSB | D |

Table 17. Acceleration measurement characteristic (–360 g to +400 g) range option...continued

$V_{DDM\ Min} \leq V_{DD} \leq V_{DDM\ Max}$, $T_{AS\ Min} \leq T_A \leq T_{AS\ Max}$, unless otherwise specified.

Transfer Function: Offset Step 7 $A\ g's = (0.088\ g/LSB \times A_{CODE}) - 45.176\ g$

Interpolated limits between –40 °C to –20 °C and between 85 °C to 125 °C

| Symbol | Parameter | Conditions | Min | Typ | Max | Unit | Notes |
|---------------------|---|------------------------------------|-----|------|-----|------|-------|
| A _{CODE7} | Acceleration measurement, 0 g, Offset step 7 | T _A = –40 °C and 125 °C | 478 | 512 | 546 | LSB | D |
| A _{CODE7} | Acceleration measurement, 22.5 g, Offset step 7 | T _A = –40 °C and 125 °C | 702 | 767 | 832 | LSB | D |
| A _{MAX7} | Acceleration measurement, 45 g, Offset step 7 | T _A = –40 °C and 125 °C | 927 | 1022 | — | LSB | D |
| A _{MIN15} | Acceleration measurement, 315 g, Offset Step 15 | –20 °C ≤ T _A ≤ 85 °C | — | 2 | — | LSB | D |
| A _{CODE15} | Acceleration measurement, 338 g, Offset Step 15 | –20 °C ≤ T _A ≤ 85 °C | — | 257 | — | LSB | D |
| A _{CODE15} | Acceleration measurement, 360 g, Offset Step 15 | –20 °C ≤ T _A ≤ 85 °C | — | 512 | — | LSB | D |
| A _{CODE15} | Acceleration measurement, 383 g, Offset Step 15 | –20 °C ≤ T _A ≤ 85 °C | — | 767 | — | LSB | D |
| A _{MAX15} | Acceleration measurement, 405 g, Offset Step 15 | –20 °C ≤ T _A ≤ 85 °C | — | 1022 | — | LSB | D |
| A _{DRIFT} | Acceleration measurement drift | — | –4 | — | +4 | LSB | C |

6.11.3 Acceleration measurement characteristic (–175 g to +550 g) range option

Table 18. Acceleration measurement characteristic (–175 g to +550 g) range option

$V_{DDM\ Min} \leq V_{DD} \leq V_{DDM\ Max}$, $T_{AS\ Min} \leq T_A \leq T_{AS\ Max}$, unless otherwise specified.

Transfer Function: Offset Step 7 $A\ g's = (0.343\ g/LSB \times A_{CODE}) - 175.686\ g$

Interpolated limits between –40 °C to –20 °C and between 85 °C to 125 °C

Due to the inverted polarity calibration where the offset steps are in reverse order, the standard library function

TPMS_READ_DYNAMIC_ACCEL is not compatible with this range option.

| Symbol | Parameter | Conditions | Min | Typ | Max | Unit | Notes |
|-----------------------|--|---------------------------------|-------|-------|-------|---------|-------|
| ΔA _{MAX-MIN} | Sensitivity | | 0.302 | 0.343 | 0.398 | g / LSB | C |
| A _{ERROR} | Error | | | 0 | | LSB | C |
| A _{UNDER} | Underflow | FW error status bit 0 = 1 | | 1 | | LSB | C |
| A _{OVER} | Overflow | FW error status bit 0 = 1 | | 1023 | | LSB | C |
| A _{MIN4} | Acceleration measurement, 200 g, Offset step 4 | –20 °C ≤ T _A ≤ 85 °C | — | 2 | — | LSB | D |
| A _{CODE4} | Acceleration measurement, 288 g, Offset step 4 | –20 °C ≤ T _A ≤ 85 °C | — | 257 | — | LSB | D |
| A _{CODE4} | Acceleration measurement, 375 g, Offset step 4 | –20 °C ≤ T _A ≤ 85 °C | — | 512 | — | LSB | D |
| A _{CODE4} | Acceleration measurement, 463 g, Offset step 4 | –20 °C ≤ T _A ≤ 85 °C | — | 767 | — | LSB | D |
| A _{MAX4} | Acceleration measurement, 550 g, Offset step 4 | –20 °C ≤ T _A ≤ 85 °C | — | 1022 | — | LSB | D |
| A _{MIN5} | Acceleration measurement, 75 g, Offset step 5 | –20 °C ≤ T _A ≤ 85 °C | — | 2 | — | LSB | D |
| A _{CODE5} | Acceleration measurement, 163 g, Offset step 5 | –20 °C ≤ T _A ≤ 85 °C | — | 257 | — | LSB | D |

Table 18. Acceleration measurement characteristic (–175 g to +550 g) range option...continued

$V_{DDM\ Min} \leq V_{DD} \leq V_{DDM\ Max}$, $T_{AS\ Min} \leq T_A \leq T_{AS\ Max}$, unless otherwise specified.

Transfer Function: Offset Step 7 $A\ g's = (0.343\ g/LSB \times A_{CODE}) - 175.686\ g$

Interpolated limits between –40 °C to –20 °C and between 85 °C to 125 °C

Due to the inverted polarity calibration where the offset steps are in reverse order, the standard library function TPMS_READ_DYNAMIC_ACCEL is not compatible with this range option.

| Symbol | Parameter | Conditions | Min | Typ | Max | Unit | Notes |
|---------------------|---|----------------------|-----|------|-----|------|-------|
| A _{CODE5} | Acceleration measurement, 250 g, Offset step 5 | -20 °C ≤ TA ≤ 85 °C | — | 512 | — | LSB | D |
| A _{CODE5} | Acceleration measurement, 338 g, Offset step 5 | -20 °C ≤ TA ≤ 85 °C | — | 767 | — | LSB | D |
| A _{MAX5} | Acceleration measurement, 425 g, Offset step 5 | -20 °C ≤ TA ≤ 85 °C | — | 1022 | — | LSB | D |
| A _{MIN6} | Acceleration measurement, -50 g, Offset step 6 | -20 °C ≤ TA ≤ 85 °C | — | 2 | — | LSB | D |
| A _{CODE6} | Acceleration measurement, 38 g, Offset step 6 | -20 °C ≤ TA ≤ 85 °C | — | 257 | — | LSB | D |
| A _{CODE6} | Acceleration measurement, 125 g, Offset step 6 | -20 °C ≤ TA ≤ 85 °C | — | 512 | — | LSB | D |
| A _{CODE6} | Acceleration measurement, 213 g, Offset step 6 | -20 °C ≤ TA ≤ 85 °C | — | 767 | — | LSB | D |
| A _{MAX6} | Acceleration measurement, 300 g, Offset step 6 | -20 °C ≤ TA ≤ 85 °C | — | 1022 | — | LSB | D |
| A _{MIN 7} | Acceleration measurement, –175 g, Offset step 7 | -20 °C ≤ TA ≤ 85 °C | — | 2 | 60 | LSB | D |
| A _{CODE 7} | Acceleration measurement, –88 g, Offset step 7 | -20 °C ≤ TA ≤ 85 °C | 224 | 257 | 290 | LSB | D |
| A _{CODE 7} | Acceleration measurement, 0 g, Offset step 7 | -20 °C ≤ TA ≤ 85 °C | 504 | 512 | 520 | LSB | A |
| A _{CODE 7} | Acceleration measurement, 88 g, Offset step 7 | -20 °C ≤ TA ≤ 85 °C | 734 | 767 | 800 | LSB | D |
| A _{MAX 7} | Acceleration measurement, 175 g, Offset step 7 | -20 °C ≤ TA ≤ 85 °C | 964 | 1022 | — | LSB | D |
| A _{MIN 7} | Acceleration measurement, –175 g, Offset step 7 | TA = -40 °C & 125 °C | — | 2 | 72 | LSB | D |
| A _{CODE 7} | Acceleration measurement, –88 g, Offset step 7 | TA = -40 °C & 125 °C | 218 | 257 | 296 | LSB | D |
| A _{CODE 7} | Acceleration measurement, 0 g, Offset step 7 | TA = -40 °C & 125 °C | 503 | 512 | 525 | LSB | D |
| A _{CODE 7} | Acceleration measurement, 88 g, Offset step 7 | TA = -40 °C & 125 °C | 728 | 767 | 806 | LSB | D |
| A _{MAX 7} | Acceleration measurement, 175 g, Offset step 7 | TA = -40 °C & 125 °C | 952 | 1022 | — | LSB | D |
| A _{MIN 8} | Acceleration measurement, –300 g, Offset step 8 | -20 °C ≤ TA ≤ 85 °C | — | 2 | — | LSB | D |
| A _{CODE 8} | Acceleration measurement, –213 g, Offset step 8 | -20 °C ≤ TA ≤ 85 °C | — | 257 | — | LSB | D |
| A _{CODE 8} | Acceleration measurement, –125 g, Offset step 8 | -20 °C ≤ TA ≤ 85 °C | — | 512 | — | LSB | D |
| A _{CODE 8} | Acceleration measurement, –38 g, Offset step 8 | -20 °C ≤ TA ≤ 85 °C | — | 767 | — | LSB | D |

Table 18. Acceleration measurement characteristic (–175 g to +550 g) range option...continued

$V_{DDM\ Min} \leq V_{DD} \leq V_{DDM\ Max}$, $T_{AS\ Min} \leq T_A \leq T_{AS\ Max}$, unless otherwise specified.

Transfer Function: Offset Step 7 A g's = $(0.343\ g/LSB \times A_{CODE}) - 175.686\ g$

Interpolated limits between –40 °C to –20 °C and between 85 °C to 125 °C

Due to the inverted polarity calibration where the offset steps are in reverse order, the standard library function TPMS_READ_DYNAMIC_ACCEL is not compatible with this range option.

| Symbol | Parameter | Conditions | Min | Typ | Max | Unit | Notes |
|----------------------|--|---------------------|-----|------|-----|------|-------|
| A _{MAX} 8 | Acceleration measurement, 50 g, Offset step 8 | -20 °C ≤ TA ≤ 85 °C | — | 1022 | — | LSB | D |
| A _{MIN} 9 | Acceleration measurement, –425 g, Offset step 9 | -20 °C ≤ TA ≤ 85 °C | — | 2 | — | LSB | D |
| A _{CODE} 9 | Acceleration measurement, –338 g, Offset step 9 | -20 °C ≤ TA ≤ 85 °C | — | 257 | — | LSB | D |
| A _{CODE} 9 | Acceleration measurement, –250 g, Offset step 9 | -20 °C ≤ TA ≤ 85 °C | — | 512 | — | LSB | D |
| A _{CODE} 9 | Acceleration measurement, –163 g, Offset step 9 | -20 °C ≤ TA ≤ 85 °C | — | 767 | — | LSB | D |
| A _{MAX} 9 | Acceleration measurement, –75 g, Offset step 9 | -20 °C ≤ TA ≤ 85 °C | — | 1022 | — | LSB | D |
| A _{MIN} 10 | Acceleration measurement, –550 g, Offset step 10 | -20 °C ≤ TA ≤ 85 °C | — | 2 | — | LSB | D |
| A _{CODE} 10 | Acceleration measurement, –463 g, Offset step 10 | -20 °C ≤ TA ≤ 85 °C | — | 257 | — | LSB | D |
| A _{CODE} 10 | Acceleration measurement, –375 g, Offset step 10 | -20 °C ≤ TA ≤ 85 °C | — | 512 | — | LSB | D |
| A _{CODE} 10 | Acceleration measurement, –288 g, Offset step 10 | -20 °C ≤ TA ≤ 85 °C | — | 767 | — | LSB | D |
| A _{MAX} 10 | Acceleration measurement, –200 g, Offset step 10 | -20 °C ≤ TA ≤ 85 °C | — | 1022 | — | LSB | D |
| A _{DRIFT} | Inertia drift | | –4 | | +4 | LSB | C |

6.11.4 Acceleration measurement characteristic (–400 g to +400 g) range option

Table 19. Acceleration measurement characteristic (–400 g to +400 g) range option

$V_{DDM\ Min} \leq V_{DD} \leq V_{DDM\ Max}$, $T_{AS\ Min} \leq T_A \leq T_{AS\ Max}$, unless otherwise specified.

Transfer Function: Offset Step 7 A g's = $(0.294\ g/LSB \times A_{CODE}) - 150.59\ g$

Interpolated limits between –40 °C to –20 °C and between 85 °C to 125 °C

| Symbol | Parameter | Conditions | Min | Typ | Max | Unit | Notes |
|-----------------------|---|---------------------------|-------|-------|-------|---------|-------|
| ΔA _{MAX-MIN} | Sensitivity | | 0.260 | 0.294 | 0.342 | g / LSB | C |
| A _{ERROR} | Error | | | 0 | | LSB | C |
| A _{UNDER} | Underflow | FW error status bit 0 = 1 | | 1 | | LSB | C |
| A _{OVER} | Overflow | FW error status bit 0 = 1 | | 1023 | | LSB | C |
| A _{MIN} 6 | Acceleration measurement, –400 g, Offset step 6 | -20 °C ≤ TA ≤ 85 °C | — | 2 | — | LSB | D |
| A _{CODE} 6 | Acceleration measurement, –325 g, Offset step 6 | -20 °C ≤ TA ≤ 85 °C | — | 257 | — | LSB | D |
| A _{CODE} 6 | Acceleration measurement, –250 g, Offset step 6 | -20 °C ≤ TA ≤ 85 °C | — | 512 | — | LSB | D |
| A _{CODE} 6 | Acceleration measurement, –175 g, Offset step 6 | -20 °C ≤ TA ≤ 85 °C | — | 767 | — | LSB | D |

Table 19. Acceleration measurement characteristic (–400 g to +400 g) range option...continued

$V_{DDM} Min \leq V_{DD} \leq V_{DDM} Max$, $T_{AS} Min \leq T_A \leq T_{AS} Max$, unless otherwise specified.

Transfer Function: Offset Step 7 $A g's = (0.294 g/LSB \times A_{CODE}) - 150.59 g$

Interpolated limits between –40 °C to –20 °C and between 85 °C to 125 °C

| Symbol | Parameter | Conditions | Min | Typ | Max | Unit | Notes |
|---------------------|---|----------------------|-----|------|-----|------|-------------------|
| A _{MAX} 6 | Acceleration measurement, –100 g, Offset step 6 | -20 °C ≤ TA ≤ 85 °C | — | 1022 | — | LSB | D |
| A _{MIN} 7 | Acceleration measurement, –150 g, Offset step 7 | -20 °C ≤ TA ≤ 85 °C | — | 2 | 61 | LSB | D |
| A _{CODE} 7 | Acceleration measurement, –75 g, Offset step 7 | -20 °C ≤ TA ≤ 85 °C | 223 | 257 | 291 | LSB | D |
| A _{CODE} 7 | Acceleration measurement, 0 g, Offset step 7 | -20 °C ≤ TA ≤ 85 °C | 503 | 512 | 521 | LSB | A |
| A _{CODE} 7 | Acceleration measurement, 75 g, Offset step 7 | -20 °C ≤ TA ≤ 85 °C | 733 | 767 | 801 | LSB | D |
| A _{MAX} 7 | Acceleration measurement, 150 g, Offset step 7 | -20 °C ≤ TA ≤ 85 °C | 963 | 1022 | — | LSB | D |
| A _{MIN} 7 | Acceleration measurement, –150 g, Offset step 7 | TA = -40 °C & 125 °C | — | 2 | 73 | LSB | D |
| A _{CODE} 7 | Acceleration measurement, –75 g, Offset step 7 | TA = -40 °C & 125 °C | 216 | 257 | 298 | LSB | D |
| A _{CODE} 7 | Acceleration measurement, 0 g, Offset step 7 | TA = -40 °C & 125 °C | 501 | 512 | 523 | LSB | D |
| A _{CODE} 7 | Acceleration measurement, 75 g, Offset step 7 | TA = -40 °C & 125 °C | 726 | 767 | 808 | LSB | D |
| A _{MAX} 7 | Acceleration measurement, 150 g, Offset step 7 | TA = -40 °C & 125 °C | 951 | 1022 | — | LSB | D |
| A _{MIN} 8 | Acceleration measurement, 100 g, Offset step 8 | -20 °C ≤ TA ≤ 85 °C | — | 2 | — | LSB | D |
| A _{CODE} 8 | Acceleration measurement, 175 g, Offset step 8 | -20 °C ≤ TA ≤ 85 °C | — | 257 | — | LSB | D |
| A _{CODE} 8 | Acceleration measurement, 250 g, Offset step 8 | -20 °C ≤ TA ≤ 85 °C | — | 512 | — | LSB | D |
| A _{CODE} 8 | Acceleration measurement, 325 g, Offset step 8 | -20 °C ≤ TA ≤ 85 °C | — | 767 | — | LSB | D |
| A _{MAX} 8 | Acceleration measurement, 400 g, Offset step 8 | -20 °C ≤ TA ≤ 85 °C | — | 1022 | — | LSB | D |
| A _{DRIFT} | Inertia drift | | –5 | | +5 | LSB | C |

6.12 Low frequency receiver characteristics

Table 20. LFR characteristics

$V_{DDF} Min \leq V_{DD} \leq V_{DDF} Max$, $T_{AF} Min \leq T_A \leq T_{AF} Max$, unless otherwise specified.

| Symbol | Parameter | Conditions | Min | Typ | Max | Unit | Notes |
|----------------------|--|--------------------------|------|-----|-----|------|-------------------|
| R _{LDFD} | LFA / LFB load resistance | — | 0.8 | — | 4 | MΩ | D |
| DR _{LFIN} | Dynamic range, f _c at BW _{ACC} | Data mode, always detect | 56 | — | — | dB | D |
| V _{IN-AD-H} | Sensitivity, high - carrier and data modes | Always detect | — | — | 3.0 | mVPP | B |
| V _{IN-ND-H} | Sensitivity, high - carrier and data modes | Never detect | 0.25 | — | — | mVPP | B |

Table 20. LFR characteristics...continued

$V_{DDF\ Min} \leq V_{DD} \leq V_{DDF\ Max}$, $T_{AF\ Min} \leq T_A \leq T_{AF\ Max}$, unless otherwise specified.

| Symbol | Parameter | Conditions | Min | Typ | Max | Unit | Notes |
|----------------------|---|---------------|------|---------|---------|-------|-------|
| V _{IN-AD-L} | Sensitivity, low - carrier and data modes | Always detect | — | — | 12.0 | mVPP | B |
| V _{IN-ND-L} | Sensitivity, low - carrier and data modes | Never detect | 4.0 | — | — | mVPP | B |
| MD | Modulation depth | — | 70 | — | 100 | % | C |
| BRLF | Baud rate | — | 3788 | 3906 | 4032 | Bit/s | C |
| DCM | Manchester duty cycle tolerance | — | — | 40 / 60 | 45 / 55 | % | C |
| DCN | NRZ duty cycle tolerance | — | — | 50 / 50 | 45 / 55 | % | C |
| MER | Message error rate | — | — | 5 | — | % | C |
| BW _{ACC} | Bandwidth | Always detect | ≥ 88 | — | ≤ 175 | kHz | C |
| BW _{REJ} | Bandwidth | Never detect | < 88 | — | > 175 | kHz | C |
| t _{LF} | Signal rise / decay time constant, carrier envelope | — | 15.3 | — | — | μs | D |

6.13 Radio frequency transmitter characteristics

Table 21. Radio frequency transmitter characteristics

$V_{DDS\ Min} \leq V_{DD} \leq V_{DDS\ Max}$, $T_{AS\ Min} \leq T_A \leq T_{AS\ Max}$, unless otherwise specified.

All conditions characterized with NDK NX2016SA 26.000 MHz crystal.

| Symbol | Parameter | Conditions | Min | Typ | Max | Unit | Notes |
|----------|--|--|------|------|------|-----------|-------|
| PRF3 | Nominal output power w/ 50 Ω matching network | 315 MHz, 25 °C, 3.0 V PWR[4:0] = 0 1 1 0 0 | — | 5 | — | dBm | C |
| PRF4 | Nominal output power w/ 50 Ω matching network | 434 MHz, 25 °C, 3.0 V PWR[4:0] = 0 1 1 1 0 | — | 5 | — | dBm | C |
| PRF | Output power, range | — | -1.5 | — | 8 | dBm | C |
| PRFSTEP | Output power, step size | — | — | 0.5 | — | dBm | C |
| PRFMINp | Output power, minimum PRF vs. T _A and V _{DD} under control of FW TPMS_RF_DYNAMIC_POWER | -40 °C ≤ T _A ≤ 0 °C and 1.8 V ≤ V _{DD} ≤ 2.5 V, or 0 °C ≤ T _A ≤ 125 °C and 2.5 V ≤ V _{DD} ≤ 3.6 V | 3 | — | — | dBm | C |
| PRFMINn | Output power, minimum PRF vs. T _A and V _{DD} under control of FW TPMS_RF_DYNAMIC_POWER | 25 °C ≤ T _A ≤ 60 °C and 2.5 V ≤ V _{DD} ≤ 3.6 V | 5 | — | — | dBm | C |
| PRFMIN00 | Output power, Step = 00 | — | — | -10 | — | dBm | C |
| FSK | Frequency shift key step | — | — | 3.17 | — | kHz | D |
| MOOK | On off key modulation depth | — | 60 | 80 | — | dBc | C |
| BRRF | Baud rate range | — | 1.2 | — | 38.4 | kbits/sec | C |
| DR | Manchester encoding bit/s accuracy, based on MFO | — | -5 | — | +5 | % | D |
| DC | Modulation duty cycle, FSK, and OOK | — | 45 | 50 | 55 | % | C |
| FxTAL | External crystal frequency, all conditions | — | — | 26 | — | MHz | D |

Table 21. Radio frequency transmitter characteristics...continued

$V_{DDs} Min \leq V_{DD} \leq V_{DDs} Max$, $T_{AS} Min \leq T_A \leq T_{AS} Max$, unless otherwise specified.
 All conditions characterized with NDK NX2016SA 26.000 MHz crystal.

| Symbol | Parameter | Conditions | Min | Typ | Max | Unit | Notes |
|---------------------|--|---|-----|------|------|-----------|-------|
| t _{S-RCTS} | Fixed portion, RF start-up process | Typ = 25 °C, 3.0 V, Max = T _{AS} Min to Max & V _{DDs} Min to Max | — | 500 | 620 | µs | C |
| Bits | Variable portion, RF start-up process | — | — | 3 | — | bit times | C |
| t _{RF2} | Total RF start time, write of SEND bit to start of RF output, at 2000 bit/s, where t _{RF} = t _{S-RCTS} + (Bits * bit/s ⁻¹ - 1) | Typ = 25 °C, 3.0 V, Max = T _{AS} Min to Max & V _{DDs} Min to Max | — | 2 | 2.2 | ms | C |
| t _{RF9} | Total RF start time, write of SEND bit to start of RF output, at 9600 bit/s, where t _{RF} = t _{S-RCTS} + (Bits * bit/s ⁻¹ - 1) | Typ = 25 °C, 3.0 V, Max = T _{AS} Min to Max & V _{DDs} Min to Max | — | 800 | 920 | µs | C |
| t _{RF20} | Total RF start time, write of SEND bit to start of RF output, at 20000 bit/s, where t _{RF} = t _{S-RCTS} + (Bits * bit/s ⁻¹ - 1) | Typ = 25 °C, 3.0 V, Max = T _{AS} Min to Max & V _{DDs} Min to Max | — | 640 | 760 | µs | C |
| H2 | Harmonic 2, 315 MHz or 434 MHz, with 50 Ω matching network, power step adjusted to reach target power in each domain. | — | — | — | -22 | dBc | C |
| H3 | Harmonic 3, 315 MHz or 434 MHz, with 50 Ω matching network, power step adjusted to reach target power in each domain. | — | — | — | -31 | dBc | C |
| H4 | Harmonic 4, 315 MHz or 434 MHz, with 50 Ω matching network, power step adjusted to reach target power in each domain. | — | — | — | -40 | dBc | C |
| N3PH10k | 315 MHz phase noise, ±10 kHz, Boost = 0 | Typ = 25 °C, 3.0 V, Max = T _{AS} Min to Max & V _{DDs} Min to Max | — | -87 | -78 | dBc / Hz | C |
| N3PH100k | 315 MHz phase noise, ±100 kHz, Boost = 0 | Typ = 25 °C, 3.0 V, Max = T _{AS} Min to Max & V _{DDs} Min to Max | — | -95 | -87 | dBc / Hz | C |
| N3PH1M | 315 MHz phase noise, ±1 MHz, Boost = 0 | Typ = 25 °C, 3.0 V, Max = T _{AS} Min to Max & V _{DDs} Min to Max | — | -82 | -77 | dBc / Hz | C |
| N31PH10k | 315 MHz phase noise, ±10 kHz, Boost = 1 | Typ = 25 °C, 3.0 V, Max = T _{AS} Min to Max & V _{DDs} Min to Max | — | -75 | -66 | dBc / Hz | C |
| N31PH100k | 315 MHz phase noise, ±100 kHz, Boost = 1 | Typ = 25 °C, 3.0 V, Max = T _{AS} Min to Max & V _{DDs} Min to Max | — | -83 | -75 | dBc / Hz | C |
| N31PH1M | 315 MHz phase noise, ±1 MHz, Boost = 1 | Typ = 25 °C, 3.0 V, Max = T _{AS} Min to Max & V _{DDs} Min to Max | — | -96 | -93 | dBc / Hz | C |
| N4PH10k | 434 MHz phase noise, ±10 kHz, Boost = 0 | Typ = 25 °C, 3.0 V, Max = T _{AS} Min to Max & V _{DDs} Min to Max | — | -85 | -75 | dBc / Hz | C |
| N4PH100k | 434 MHz phase noise, ±100 kHz, Boost = 0 | Typ = 25 °C, 3.0 V, Max = T _{AS} Min to Max & V _{DDs} Min to Max | — | -92 | -83 | dBc / Hz | C |
| N4PH1M | 434 MHz phase noise, ±1 MHz, Boost = 0 | Typ = 25 °C, 3.0 V, Max = T _{AS} Min to Max & V _{DDs} Min to Max | — | -83 | -78 | dBc / Hz | C |
| NPH10M | Phase noise, ±10 MHz | Typ = 25 °C, 3.0 V, Max = T _{AS} Min to Max & V _{DDs} Min to Max | — | -105 | -101 | dBc / Hz | C |
| NSP315 | Spurious noise, <1 GHz, 10 kHz BW 315 MHz FCC 15.231a-e | — | — | — | -30 | dBc | C |

Table 21. Radio frequency transmitter characteristics...continued

$V_{DDs} Min \leq V_{DD} \leq V_{DDs} Max$, $T_{AS} Min \leq T_A \leq T_{AS} Max$, unless otherwise specified.

All conditions characterized with NDK NX2016SA 26.000 MHz crystal.

| Symbol | Parameter | Conditions | Min | Typ | Max | Unit | Notes |
|---------------------|--|--------------------------|-----|-----|------|------|-------|
| NSPUG | Spurious noise, < 1 GHz, 10 kHz BW 434 MHz ETSI EN300220 | — | — | — | -40 | dBc | C |
| NSPOG | Spurious noise, >1 GHz, 10 kHz BW 434 MHz ETSI EN300220 | — | — | — | -40 | dBc | C |
| OBWKF | Occupied bandwidth, < ±35 kHz FSK up to 19.2 kbit/s Korea, MIC 2007-63 | — | — | — | 200 | kHz | C |
| OBWKO | Occupied bandwidth, OOK up to 9.6 kbit/s, Korea, MIC 2007-64 | — | — | — | 200 | kHz | C |
| OBWJF | Occupied bandwidth, < ±45 kHz FSK up to 38.4 kbit/s, Japan, ARIB STD- T93 | — | — | — | 400 | kHz | C |
| OBWJO | Occupied bandwidth, OOK up to 19.2 kbit/s, Japan, ARIB STD-T94 | — | — | — | 600 | kHz | C |
| ML | Oscillation margin | — | 850 | — | — | Ω | D |
| f _{XCO} | Internal oscillator accuracy | — | -10 | — | +10 | ppm | D |
| V _{AREGOK} | RF V _{reg} capacitor Pre-charge voltage - Note: 0.47 μF V _{reg} capacitor connected. | V _{DDs} ≥ 2.1 V | — | 1.5 | — | V | C |
| t _{AREGOK} | RF V _{reg} capacitor Pre-charge Process - Note: 0.47 μF V _{reg} capacitor connected, additional to t _{S-RCTS} | V _{DDs} ≥ 2.1 V | — | 630 | 1000 | μSec | D |

The firmware routine TPMS_PRECHARGE_EN performs the pre-charge of RF V_{reg} capacitor. When the pre-charge is successful, the execution time of the routine corresponds to t_{AREGOK} duration. When the pre-charge fails, the routine exits after a timeout longer than t_{AREGOK} max duration.

6.14 Power consumption RF transmissions

Using the TPMS_RF_DYNAMIC_POWER firmware routine² allows adjusting the power step in order to compensate for variations of output power versus temperature and voltage. This routine is associated to a part-to-part trimming that initially adjusts the power step to compensate for process variations.

² Refer to user manual, UM11227.^[1]

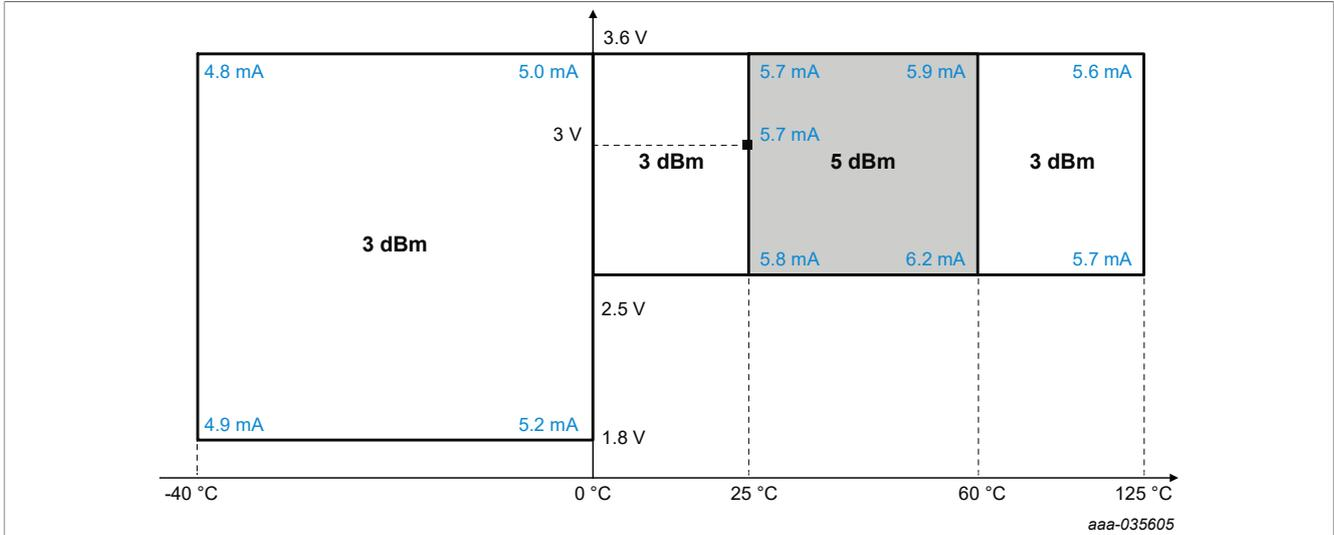

Figure 4. Dynamic power adjustment — 315 MHz

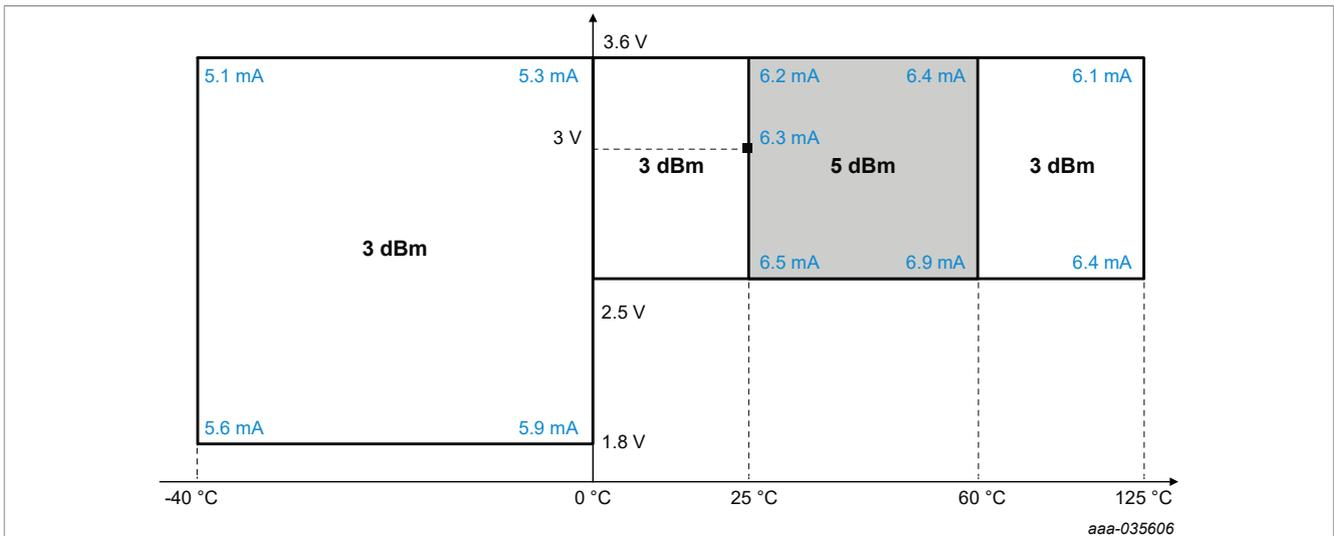

Figure 5. Dynamic power adjustment — 434 MHz

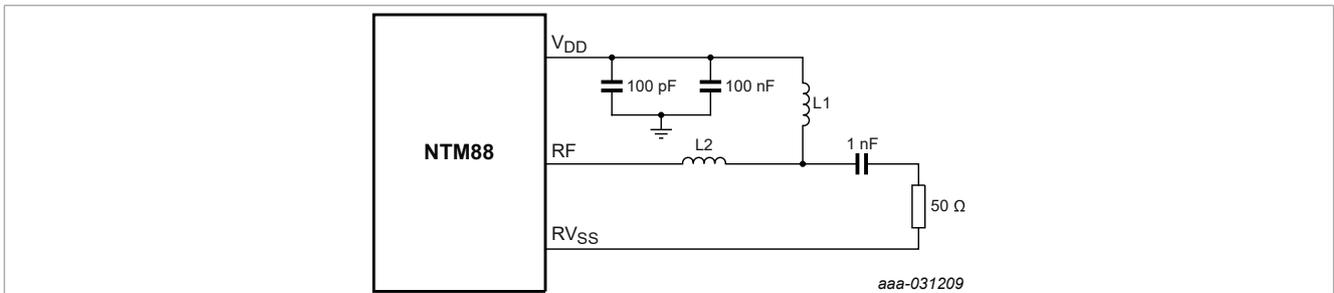

Figure 6. RF output power measurement configuration

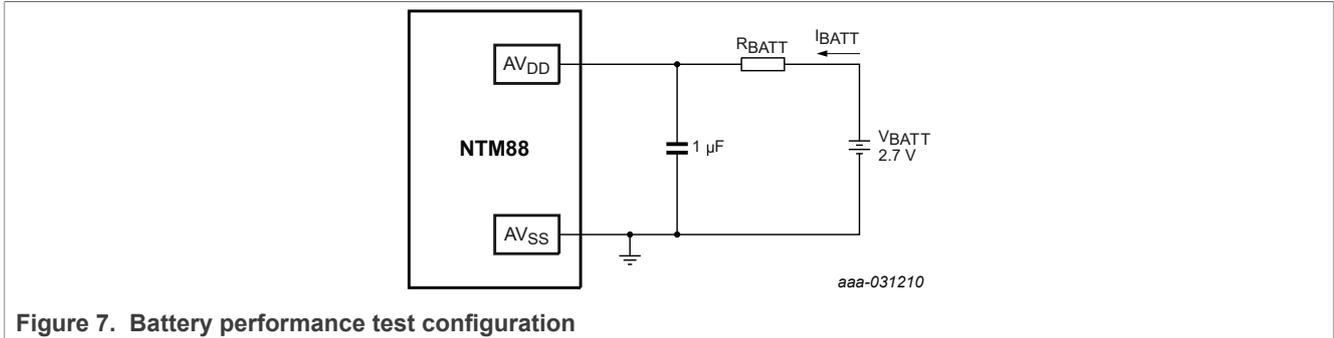

Figure 7. Battery performance test configuration

7 Mechanical specifications

7.1 Maximum ratings (mechanical)

Maximum ratings are the extreme limits the device can be exposed without permanent damage. The device contains circuitry to protect the inputs against damage from high static voltages; however, do not apply voltages higher than the values shown in [Table 22](#). Keep V_{IN} and V_{OUT} within the range $V_{SS} \leq (V_{IN} \text{ or } V_{OUT}) \leq V_{DD}$.

Table 22. Maximum ratings

| Symbol | Parameter | Conditions | Min | Typ | Max | Unit | Notes |
|---------------|---|--|------|------|------|--------------|-------------------|
| $P_{burst1k}$ | Pressure transducer, minimum burst pressure | ≤ 1200 kPa rating | 2000 | — | — | kPa | D |
| f_{P0} | Pressure transducer, minimum natural resonance frequency | — | — | 5 | — | MHz | D |
| Q_P | Pressure transducer damping ratio | — | — | 1 | — | — | D |
| PA_N | Pressure transducer, sensitivity to vertical acceleration | $-500 \text{ g} \leq A \leq +500 \text{ g}$ | — | 0 | — | Pa / g | C |
| PA_{neg} | Pressure transducer, sensitivity to vertical acceleration | $A < -500 \text{ g}$ | 2 | 4.5 | 6.5 | Pa / g | C |
| PA_{pos} | Pressure transducer, sensitivity to vertical acceleration | $A > +500 \text{ g}$ | -6.5 | -4.5 | -2 | Pa / g | C |
| f_{A0} | Accelerometer, minimum natural resonance frequency | — | 7 | — | 16 | kHz | D |
| Q_A | Accelerometer, damping ratio | — | 1 | — | 4 | — | D |
| $AP1k$ | Accelerometer, sensitivity to pressure | $90 \text{ kPa} \leq P \leq 1200 \text{ kPa}$ | -1.5 | — | +1.5 | g / 1000 kPa | C |
| A_{stop2h} | Accelerometer, minimum acceleration to reach travel stop | $\leq 100 \text{ g}$ rating | -200 | — | +200 | g | D |
| A_{stop7h} | Accelerometer, minimum acceleration to reach travel stop | $> 100 \text{ g}$ rating | -700 | — | +700 | g | D |
| A_{CROSS} | Accelerometer, maximum cross axis sensitivity | $X \rightarrow Z$, or $Z \rightarrow X$, or $X \rightarrow Y$, or $Z \rightarrow Y$ | -5 | — | +5 | % | D |
| m | Package Mass | — | — | 0.2 | — | gram | D |
| τ | Thermal time constant | — | — | 101 | — | sec | D |

7.2 Media compatibility

Media compatibility is based on media and test method described in NXP specification

NXPOMS-999116894-4501.^[2] Consult your sales representative for more details and specific requirements.

8 Mounting recommendations

The package should be mounted with the pressure port pointing away from the axis of tire rotation. By mounting the pressure port away from the axis of tire rotation, centrifugal force propels any contaminants out of the pressure port. In cases where the application must orient the pressure port pointing inward, care must be taken to assure contaminants do not reach inside the pressure port.

A plugged port exhibits no change in pressure and can be cross checked in the user software. Use the method described in user manual UM11227.^[1]

Refer to application note AN1902^[3] for proper printed circuit board attributes and recommendations.

9 Package outline

Consult the most recently issued drawing before initiating or completing a design. The drawings are available for download at https://www.nxp.com/docs/en/package-information/SOT1931-1_D.pdf.

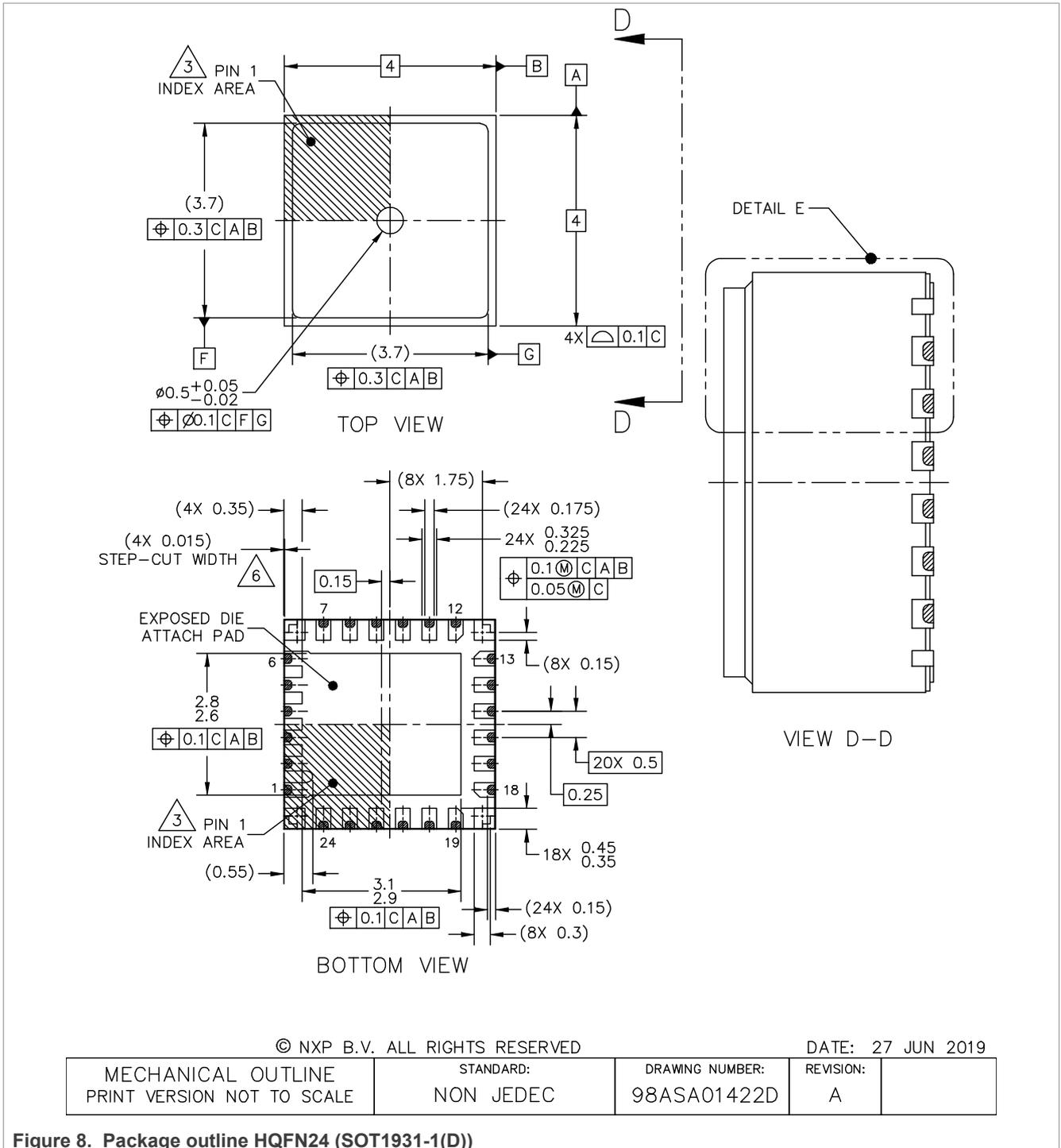

Figure 8. Package outline HQFN24 (SOT1931-1(D))

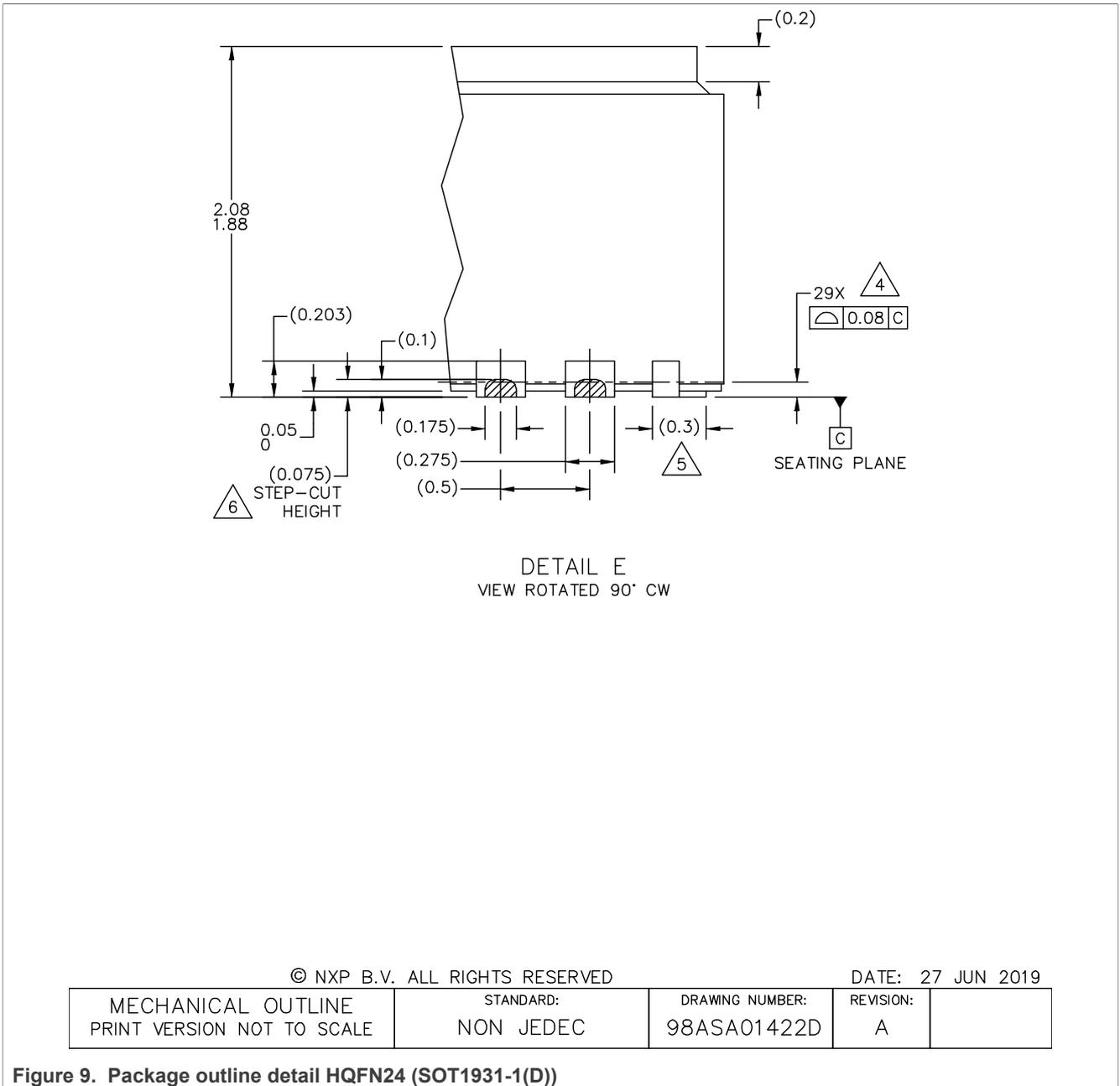
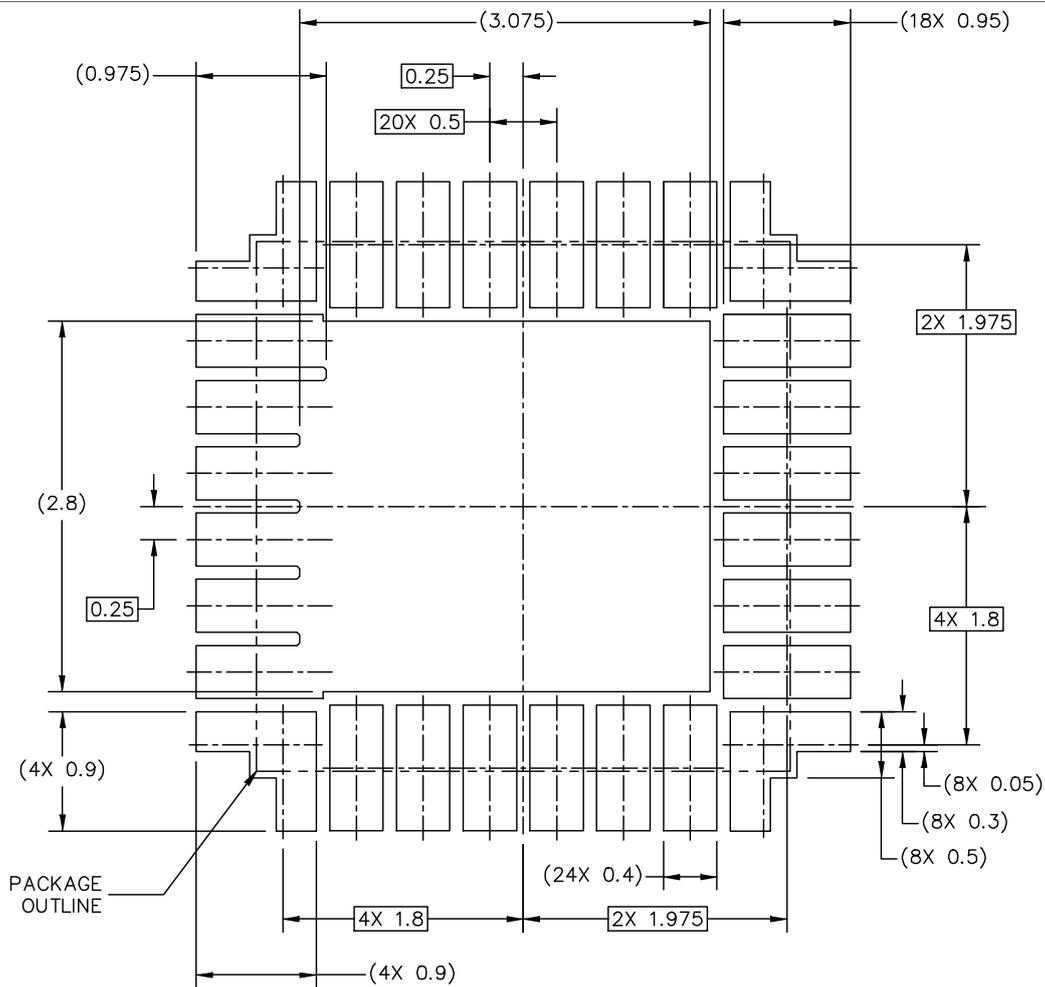

Figure 9. Package outline detail HQFN24 (SOT1931-1(D))



PCB DESIGN GUIDELINES – SOLDER MASK OPENING PATTERN

THIS SHEET SERVES ONLY AS A GUIDELINE TO HELP DEVELOP A USER SPECIFIC SOLUTION. DEVELOPMENT EFFORT WILL STILL BE REQUIRED BY END USERS TO OPTIMIZE PCB MOUNTING PROCESSES AND BOARD DESIGN IN ORDER TO MEET INDIVIDUAL/SPECIFIC REQUIREMENTS.

© NXP B.V. ALL RIGHTS RESERVED

DATE: 27 JUN 2019

| | | | | |
|--|------------------------|--------------------------------|----------------|--|
| MECHANICAL OUTLINE PRINT VERSION NOT TO SCALE | STANDARD: NON JEDEC | DRAWING NUMBER: 98ASA01422D | REVISION: A | |
|--|------------------------|--------------------------------|----------------|--|

Figure 10. Reflow soldering footprint part1 for HQFN24 (SOT1931-1(D))

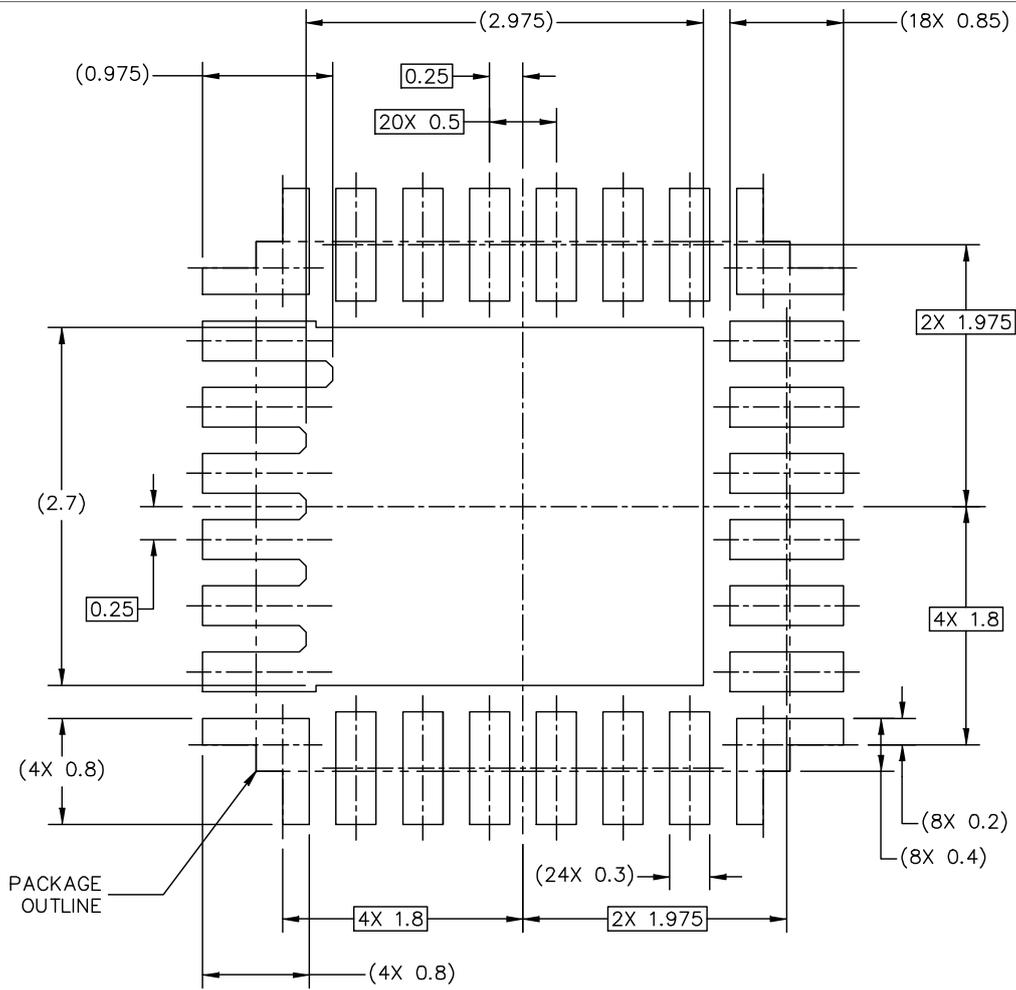

PCB DESIGN GUIDELINES – I/O PADS AND SOLDERABLE AREA

THIS SHEET SERVES ONLY AS A GUIDELINE TO HELP DEVELOP A USER SPECIFIC SOLUTION. DEVELOPMENT EFFORT WILL STILL BE REQUIRED BY END USERS TO OPTIMIZE PCB MOUNTING PROCESSES AND BOARD DESIGN IN ORDER TO MEET INDIVIDUAL/SPECIFIC REQUIREMENTS.

© NXP B.V. ALL RIGHTS RESERVED

DATE: 27 JUN 2019

| | | | | |
|--|------------------------|--------------------------------|----------------|--|
| MECHANICAL OUTLINE PRINT VERSION NOT TO SCALE | STANDARD: NON JEDEC | DRAWING NUMBER: 98ASA01422D | REVISION: A | |
|--|------------------------|--------------------------------|----------------|--|

Figure 11. Reflow soldering footprint part2 for HQFN24 (SOT1931-1(D))

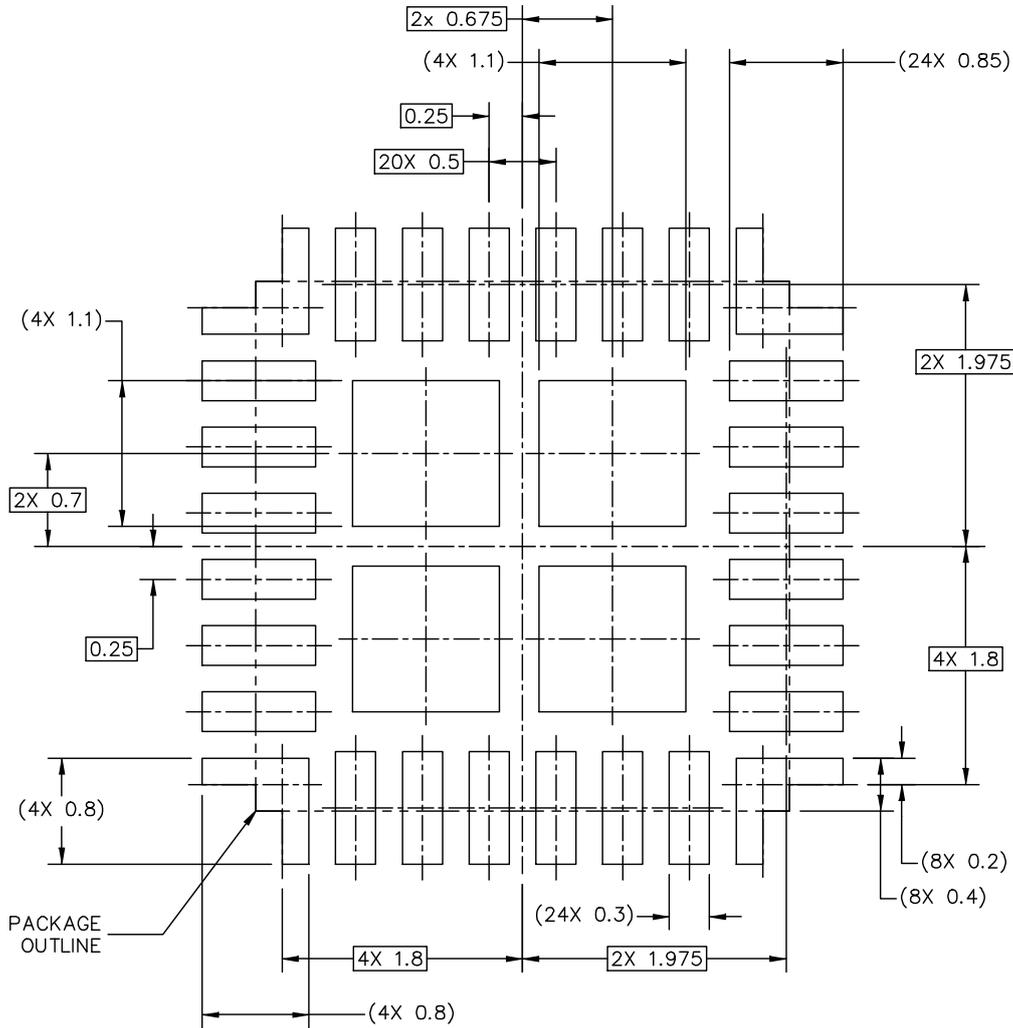

RECOMMENDED STENCIL THICKNESS 0.125

PCB DESIGN GUIDELINES – SOLDER PASTE STENCIL

THIS SHEET SERVES ONLY AS A GUIDELINE TO HELP DEVELOP A USER SPECIFIC SOLUTION. DEVELOPMENT EFFORT WILL STILL BE REQUIRED BY END USERS TO OPTIMIZE PCB MOUNTING PROCESSES AND BOARD DESIGN IN ORDER TO MEET INDIVIDUAL/SPECIFIC REQUIREMENTS.

© NXP B.V. ALL RIGHTS RESERVED

DATE: 27 JUN 2019

| | | | | |
|--|------------------------|--------------------------------|----------------|--|
| MECHANICAL OUTLINE PRINT VERSION NOT TO SCALE | STANDARD: NON JEDEC | DRAWING NUMBER: 98ASA01422D | REVISION: A | |
|--|------------------------|--------------------------------|----------------|--|

Figure 12. Reflow soldering footprint part3 for HQFN24 (SOT1931-1(D))

NOTES:

1. ALL DIMENSIONS ARE IN MILLIMETERS.
2. DIMENSIONING AND TOLERANCING PER ASME Y14.5M-1994.
3. PIN 1 FEATURE SHAPE, SIZE AND LOCATION MAY VARY.
4. COPLANARITY APPLIES TO LEADS, DIE ATTACH FLAG AND CORNER NON-FUNCTIONAL PADS.
5. ANCHORING PADS.
6. STEP-CUT IS APPLIED FOR BURR REMOVAL ONLY.

© NXP B.V. ALL RIGHTS RESERVED

DATE: 27 JUN 2019

| | | | | |
|--|------------------------|--------------------------------|----------------|--|
| MECHANICAL OUTLINE PRINT VERSION NOT TO SCALE | STANDARD: NON JEDEC | DRAWING NUMBER: 98ASA01422D | REVISION: A | |
|--|------------------------|--------------------------------|----------------|--|

Figure 13. Package outline notes HQFN24 (SOT1931-1(D))

10 References

NXP reference documents

- [1] UM11227, *NTM88 family of tire pressure monitor sensors*
- [2] NXP Specification NXPOMS-999116894-4501, *Media test for TPMS MCM automotive pressure sensors*
- [3] AN1902, *Assembly guidelines for QFN (quad flat no-lead) and SON (small outline no-lead) packages*

11 Revision history

Table 23. Revision history

| Document ID | Release date | Data sheet status | Change notice | Supersedes |
|------------------|---|----------------------|---------------|------------------|
| NTM88Hxx5S v.1.3 | 20231205 | Objective data sheet | — | NTM88Hxx5S v.1.2 |
| Modifications: | <ul style="list-style-type: none"> • Section 1, revised "...accelerometers in five ranges..." to "...accelerometers in four ranges..." • Section 3, Table 1, removed NTM88H025ST1, NTM88H055ST1, NTM88H065ST1, and NTM88H075ST1 from the table. • Section 6.11, removed the section titled "Acceleration measurement characteristics (–120 g to +520 g) range option". | | | |
| NTM88Hxx5S v.1.2 | 20230721 | Objective data sheet | — | NTM88Hxx5S v.1.1 |
| NTM88Hxx5S v.1.1 | 20230623 | Objective data sheet | — | NTM88Hxx5S v.1 |
| NTM88Hxx5S v.1 | 20221012 | Objective data sheet | — | NTM88xxx5S v.1.2 |

Legal information

Data sheet status

| Document status ^{[1][2]} | Product status ^[3] | Definition |
|-----------------------------------|-------------------------------|---|
| Objective [short] data sheet | Development | This document contains data from the objective specification for product development. |
| Preliminary [short] data sheet | Qualification | This document contains data from the preliminary specification. |
| Product [short] data sheet | Production | This document contains the product specification. |

[1] Please consult the most recently issued document before initiating or completing a design.

[2] The term 'short data sheet' is explained in section "Definitions".

[3] The product status of device(s) described in this document may have changed since this document was published and may differ in case of multiple devices. The latest product status information is available on the Internet at URL <https://www.nxp.com>.

Definitions

Draft — A draft status on a document indicates that the content is still under internal review and subject to formal approval, which may result in modifications or additions. NXP Semiconductors does not give any representations or warranties as to the accuracy or completeness of information included in a draft version of a document and shall have no liability for the consequences of use of such information.

Short data sheet — A short data sheet is an extract from a full data sheet with the same product type number(s) and title. A short data sheet is intended for quick reference only and should not be relied upon to contain detailed and full information. For detailed and full information see the relevant full data sheet, which is available on request via the local NXP Semiconductors sales office. In case of any inconsistency or conflict with the short data sheet, the full data sheet shall prevail.

Product specification — The information and data provided in a Product data sheet shall define the specification of the product as agreed between NXP Semiconductors and its customer, unless NXP Semiconductors and customer have explicitly agreed otherwise in writing. In no event however, shall an agreement be valid in which the NXP Semiconductors product is deemed to offer functions and qualities beyond those described in the Product data sheet.

Disclaimers

Limited warranty and liability — Information in this document is believed to be accurate and reliable. However, NXP Semiconductors does not give any representations or warranties, expressed or implied, as to the accuracy or completeness of such information and shall have no liability for the consequences of use of such information. NXP Semiconductors takes no responsibility for the content in this document if provided by an information source outside of NXP Semiconductors.

In no event shall NXP Semiconductors be liable for any indirect, incidental, punitive, special or consequential damages (including - without limitation - lost profits, lost savings, business interruption, costs related to the removal or replacement of any products or rework charges) whether or not such damages are based on tort (including negligence), warranty, breach of contract or any other legal theory.

Notwithstanding any damages that customer might incur for any reason whatsoever, NXP Semiconductors' aggregate and cumulative liability towards customer for the products described herein shall be limited in accordance with the Terms and conditions of commercial sale of NXP Semiconductors.

Right to make changes — NXP Semiconductors reserves the right to make changes to information published in this document, including without limitation specifications and product descriptions, at any time and without notice. This document supersedes and replaces all information supplied prior to the publication hereof.

Applications — Applications that are described herein for any of these products are for illustrative purposes only. NXP Semiconductors makes no representation or warranty that such applications will be suitable for the specified use without further testing or modification.

Customers are responsible for the design and operation of their applications and products using NXP Semiconductors products, and NXP Semiconductors accepts no liability for any assistance with applications or customer product design. It is customer's sole responsibility to determine whether the NXP Semiconductors product is suitable and fit for the customer's applications and products planned, as well as for the planned application and use of customer's third party customer(s). Customers should provide appropriate design and operating safeguards to minimize the risks associated with their applications and products.

NXP Semiconductors does not accept any liability related to any default, damage, costs or problem which is based on any weakness or default in the customer's applications or products, or the application or use by customer's third party customer(s). Customer is responsible for doing all necessary testing for the customer's applications and products using NXP Semiconductors products in order to avoid a default of the applications and the products or of the application or use by customer's third party customer(s). NXP does not accept any liability in this respect.

Limiting values — Stress above one or more limiting values (as defined in the Absolute Maximum Ratings System of IEC 60134) will cause permanent damage to the device. Limiting values are stress ratings only and (proper) operation of the device at these or any other conditions above those given in the Recommended operating conditions section (if present) or the Characteristics sections of this document is not warranted. Constant or repeated exposure to limiting values will permanently and irreversibly affect the quality and reliability of the device.

Terms and conditions of commercial sale — NXP Semiconductors products are sold subject to the general terms and conditions of commercial sale, as published at <https://www.nxp.com/profile/terms>, unless otherwise agreed in a valid written individual agreement. In case an individual agreement is concluded only the terms and conditions of the respective agreement shall apply. NXP Semiconductors hereby expressly objects to applying the customer's general terms and conditions with regard to the purchase of NXP Semiconductors products by customer.

No offer to sell or license — Nothing in this document may be interpreted or construed as an offer to sell products that is open for acceptance or the grant, conveyance or implication of any license under any copyrights, patents or other industrial or intellectual property rights.

Suitability for use in automotive applications — This NXP product has been qualified for use in automotive applications. If this product is used by customer in the development of, or for incorporation into, products or services (a) used in safety critical applications or (b) in which failure could lead to death, personal injury, or severe physical or environmental damage (such products and services hereinafter referred to as “Critical Applications”), then customer makes the ultimate design decisions regarding its products and is solely responsible for compliance with all legal, regulatory, safety, and security related requirements concerning its products, regardless of any information or support that may be provided by NXP. As such, customer assumes all risk related to use of any products in Critical Applications and NXP and its suppliers shall not be liable for any such use by customer. Accordingly, customer will indemnify and hold NXP harmless from any claims, liabilities, damages and associated costs and expenses (including attorneys’ fees) that NXP may incur related to customer’s incorporation of any product in a Critical Application.

Quick reference data — The Quick reference data is an extract of the product data given in the Limiting values and Characteristics sections of this document, and as such is not complete, exhaustive or legally binding.

Export control — This document as well as the item(s) described herein may be subject to export control regulations. Export might require a prior authorization from competent authorities.

Translations — A non-English (translated) version of a document, including the legal information in that document, is for reference only. The English version shall prevail in case of any discrepancy between the translated and English versions.

Security — Customer understands that all NXP products may be subject to unidentified vulnerabilities or may support established security standards or specifications with known limitations. Customer is responsible for the design and operation of its applications and products throughout their lifecycles to reduce the effect of these vulnerabilities on customer’s applications and products. Customer’s responsibility also extends to other open and/or proprietary technologies supported by NXP products for use in customer’s applications. NXP accepts no liability for any vulnerability. Customer should regularly check security updates from NXP and follow up appropriately. Customer shall select products with security features that best meet rules, regulations, and standards of the intended application and make the ultimate design decisions regarding its products and is solely responsible for compliance with all legal, regulatory, and security related requirements concerning its products, regardless of any information or support that may be provided by NXP.

NXP has a Product Security Incident Response Team (PSIRT) (reachable at PSIRT@nxp.com) that manages the investigation, reporting, and solution release to security vulnerabilities of NXP products.

NXP B.V. — NXP B.V. is not an operating company and it does not distribute or sell products.

Trademarks

Notice: All referenced brands, product names, service names, and trademarks are the property of their respective owners.

NXP — wordmark and logo are trademarks of NXP B.V.

Tables

| | | | | | |
|----------|---|----|----------|---|----|
| Tab. 1. | Ordering information | 2 | Tab. 15. | Pressure measurement characteristics (90 kPa to 930 kPa) range | 14 |
| Tab. 2. | Ordering options | 2 | Tab. 16. | Acceleration measurement characteristic (–80 g to +90 g) range option | 15 |
| Tab. 3. | Pin description | 4 | Tab. 17. | Acceleration measurement characteristic (–360 g to +400 g) range option | 16 |
| Tab. 4. | Electrical and mechanical specification note definition table | 7 | Tab. 18. | Acceleration measurement characteristic (–175 g to +550 g) range option | 17 |
| Tab. 5. | Maximum ratings | 8 | Tab. 19. | Acceleration measurement characteristic (–400 g to +400 g) range option | 19 |
| Tab. 6. | Operating range | 8 | Tab. 20. | LFR characteristics | 20 |
| Tab. 7. | Charge consumptions | 10 | Tab. 21. | Radio frequency transmitter characteristics | 21 |
| Tab. 8. | Clocks and thresholds | 10 | Tab. 22. | Maximum ratings | 25 |
| Tab. 9. | Power-on reset | 11 | Tab. 23. | Revision history | 33 |
| Tab. 10. | GPIO port pins | 11 | | | |
| Tab. 11. | SPI timing | 12 | | | |
| Tab. 12. | Temperature measurement | 12 | | | |
| Tab. 13. | Voltage measurement characteristics | 13 | | | |
| Tab. 14. | External pin voltage measurement | 14 | | | |

Figures

| | | | | | |
|---------|---|----|----------|--|----|
| Fig. 1. | Block diagram | 3 | Fig. 9. | Package outline detail HQFN24 (SOT1931-1(D)) | 28 |
| Fig. 2. | Pin configuration | 4 | Fig. 10. | Reflow soldering footprint part1 for HQFN24 (SOT1931-1(D)) | 29 |
| Fig. 3. | NTM88Hxx5S orientation at rest. | 7 | Fig. 11. | Reflow soldering footprint part2 for HQFN24 (SOT1931-1(D)) | 30 |
| Fig. 4. | Dynamic power adjustment — 315 MHz | 24 | Fig. 12. | Reflow soldering footprint part3 for HQFN24 (SOT1931-1(D)) | 31 |
| Fig. 5. | Dynamic power adjustment — 434 MHz | 24 | Fig. 13. | Package outline notes HQFN24 (SOT1931-1(D)) | 32 |
| Fig. 6. | RF output power measurement configuration | 24 | | | |
| Fig. 7. | Battery performance test configuration | 25 | | | |
| Fig. 8. | Package outline HQFN24 (SOT1931-1(D)) | 27 | | | |

Contents

| | | |
|-----------|---|-----------|
| 1 | General description | 1 |
| 2 | Features and benefits | 1 |
| 3 | Ordering information | 2 |
| 4 | Block diagram | 3 |
| 5 | Pinning information | 4 |
| 5.1 | Pinning | 4 |
| 5.2 | Pin description | 4 |
| 5.3 | Orientation | 7 |
| 6 | Electrical specifications | 7 |
| 6.1 | Maximum ratings (electrical) | 7 |
| 6.2 | Operating conditions | 8 |
| 6.3 | Charge consumptions | 10 |
| 6.4 | Clocks and thresholds | 10 |
| 6.5 | Power-on reset operation | 11 |
| 6.6 | GPIO port pins | 11 |
| 6.7 | SPI timing characteristics | 12 |
| 6.8 | Temperature measurement characteristics | 12 |
| 6.9 | Voltage measurement characteristics | 13 |
| 6.10 | Pressure measurement characteristics | 14 |
| 6.10.1 | Pressure measurement characteristic (90 kPa to 930 kPa) range | 14 |
| 6.11 | Acceleration measurement characteristics | 15 |
| 6.11.1 | Acceleration measurement characteristics (-80 g to +90 g) range option | 15 |
| 6.11.2 | Acceleration measurement characteristic (- 360 g to +400 g) range option | 16 |
| 6.11.3 | Acceleration measurement characteristic (- 175 g to +550 g) range option | 17 |
| 6.11.4 | Acceleration measurement characteristic (- 400 g to +400 g) range option | 19 |
| 6.12 | Low frequency receiver characteristics | 20 |
| 6.13 | Radio frequency transmitter characteristics | 21 |
| 6.14 | Power consumption RF transmissions | 23 |
| 7 | Mechanical specifications | 25 |
| 7.1 | Maximum ratings (mechanical) | 25 |
| 7.2 | Media compatibility | 26 |
| 8 | Mounting recommendations | 26 |
| 9 | Package outline | 27 |
| 10 | References | 32 |
| 11 | Revision history | 33 |
| | Legal information | 34 |

Please be aware that important notices concerning this document and the product(s) described herein, have been included in section 'Legal information'.