

High-Performance, Low-Power MPC831x Family

Ideal for video surveillance, building automation, health care, industrial control, consumer NAS and media servers

Satisfying Ever-Changing Multiple-Market Needs

While different markets seem to require different product solutions, the same key processor attributes often apply across consumer, commercial and industrial applications. Freescale, known for its design and integration capabilities, designed the versatile MPC8313E, MPC8315E and MPC8314E PowerQUICC® processors to integrate hardware for Ethernet and serial communications, memory interfaces, USB ports, security and other popular inputs and outputs in a ubiquitous architecture engineered to serve several markets equally well. Designers benefit from its legacy System-on-Chip (SoC) architecture, lower pin count and high-speed peripherals like SGMII, PCI Express® and DDRII. Based on the mature Power Architecture™ technology, this family of processors offers designers easy scalability, integrated on-chip features and the possibility of significant software reuse across product families. This can speed up development and reduce product sustaining costs.

Freescale has cost-effective evaluation boards, software and drivers for the MPC8313E and MPC8315E as well as CodeWarrior® development tools that will help speed a design to market. The MPC831x processor provides the horsepower, I/O, power envelope and enablement to meet the design requirements of a spectrum of applications, whether you are building a cost-effective consumer device or a low-power industrial device.



MPC831xE Family	
Features	Benefits
SGMII	Low pin count reduces board real estate requirements
IEEE® 1588 hardware support	Nanosecond-level clock synchronization accuracy
<2W power	Fanless operation, saves on BOM costs and increases MTBF
Power management	Enables power savings for reduced operational efficiencies and extended system life
High-speed USB	High-speed USB supports 480 Mbps operation, while full speed runs at 12 Mbps and low speed runs at 1.5 Mbps; enables a faster data rate
Comprehensive development tools including reference design board, Linux® and third-party tools	Helps to decrease time to revenue by getting designs up and running with efficiency
RAID 1 support on MPC8315E	Offloads the CPU leaving it free to run other functions
x2 SATA on MPC8315E provides direct connection to up to two hard disk drives	Optimizes BOM cost, helps to reduce overall board real estate and helps you save money on your design

Factory Automation and Control

The most significant trend in factory automation is the connection of the factory floor with enterprise systems using Ethernet as the common network. According to ARC Advisory Group shipments of industrial Ethernet devices in industrial automation will grow from 840,000 units in 2004 to 6.7 million units by 2009. This convergence of traditional corporate IT and factory floor automation presents a challenge for engineers trying to make automation design decisions.

One driver for connectivity to the factory floor is the need to make machine performance and maintenance data visible to engineers in the factory. This helps engineers to troubleshoot manufacturing problems, extend product lifetimes and reduce maintenance costs. However the primary driver for this connectivity is the need for factory floor data to be analyzed for supply chain optimization, asset utilization, capacity planning and product tracking.

Device management and a connected factory floor require a protected network that cross-communicates via wireless, cable and fiber mediums to efficiently manage industrial control and connectivity. This connectivity lowers operating costs and improves product and service quality and reliability. Freescale's competitively priced MPC831x processor, with IEEE® 1588 and power management



features, brings Ethernet-based protocol processing into this arena.

- Junction temperature range -40° to +105°C
- <2W typical power, helps support fanless designs in harsh environments

Features for the Market

- Integrated Ethernet controllers support Industrial Ethernet protocols for access to networked devices on the factory floor to help reduce system management costs
- IEEE 1588 hardware support designed to give nanosecond-level clock synchronization accuracy for extremely precise industrial clock-synchronization

Applications

- Test and Instrumentation
- Industrial Automation
- Service Robotics
- Process Manufacturing Control

Factory Automation and Control

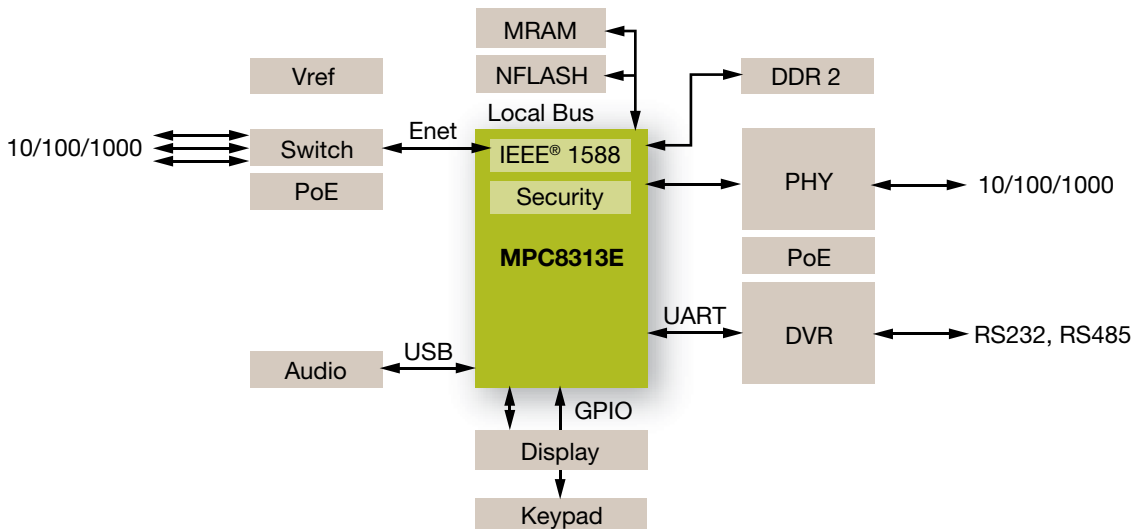

Security and Surveillance

Effective security surveillance in airports, government buildings, retail sites and homes often requires functionality that exceeds the capabilities of historical VCR-based systems. To help meet today's demanding requirements, surveillance solutions must provide greater intelligence, higher bandwidth, system redundancy, easier data backup and disaster recovery and remote maintenance, plus scalability for future growth. The MPC8315E processor integrates the features and performance required to meet the needs of security and surveillance applications, including SATA for locally accessed and stored data in a video surveillance environment.

Features for the Market

- Ethernet for network connectivity and remote monitoring such as in CCTV applications
- IEEE 1588 clock synchronization accuracy measured in nanoseconds provides information on when each event occurred in a networked system
- Integrated hardware encryption on MPC831x—AES, DES, 3DES, SHA-1 helps to enable secure transmission of sensitive data

- High throughput at the I/O interface to help ensure timely information is delivered to security stations
- Integrated SATA controller designed to enable local storage and management of data

Applications

- Video Surveillance
- Security Camera

Intelligent Surveillance System

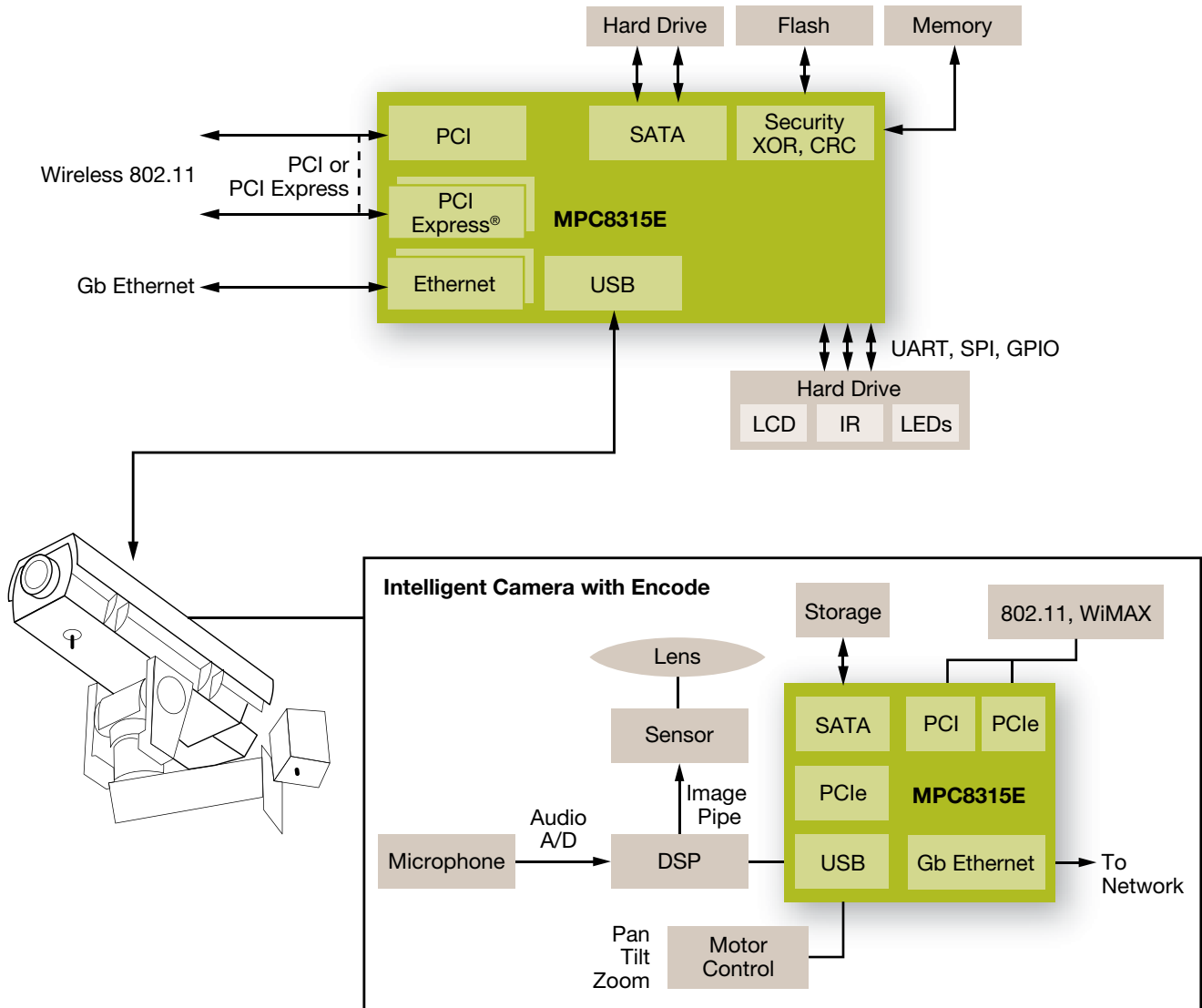

Freescale technology

Health Care Instrumentation

Health care industry demand for networked health care devices is growing. The Health Insurance Portability and Accountability Act (HIPAA) of 1996, industry consolidations and the push toward patient management within alternate-care sites—all contribute to the need for equipment manufacturers to supply products with reliable networking capabilities. Fortunately, advances in networking technology and the Internet are enabling health care providers to create an environment where health care devices, equipment, and systems are communicating with one another—over networks and the Internet—in health care environments as diverse as hospitals, nursing homes, outpatient care centers and patients’ homes.

The industry is demanding device networking solutions based on de facto standards like Ethernet and Internet Protocol (IP) because health care product end-users want real-time access to information, reductions in maintenance costs through remote monitoring and management, and the ability to leverage existing Ethernet wiring, corporate IP networks and the Internet.

In addition, the use of high-speed serial buses in the health care industry has prompted the need for a solution to facilitate system expansion for custom peripherals that are critical to fast-evolving health care device technology. Highly integrated processors help facilitate the ability to distribute and utilize patient information to help improve patient care and reduce costs, by delivering control and communication in one solution along with a varied level of I/O interfaces.

Features for the Market

- 8- to 10-year product lifetime addresses the requirement for regulatory approval processes
- Integrated Ethernet controllers for network connectivity and remote monitoring are supported by a wide assortment of commercial protocols
- Serial interfaces designed to enable network integration in health-related equipment
- 700+ MIPS with FPU for analytical calculations

Patient Monitor Hub

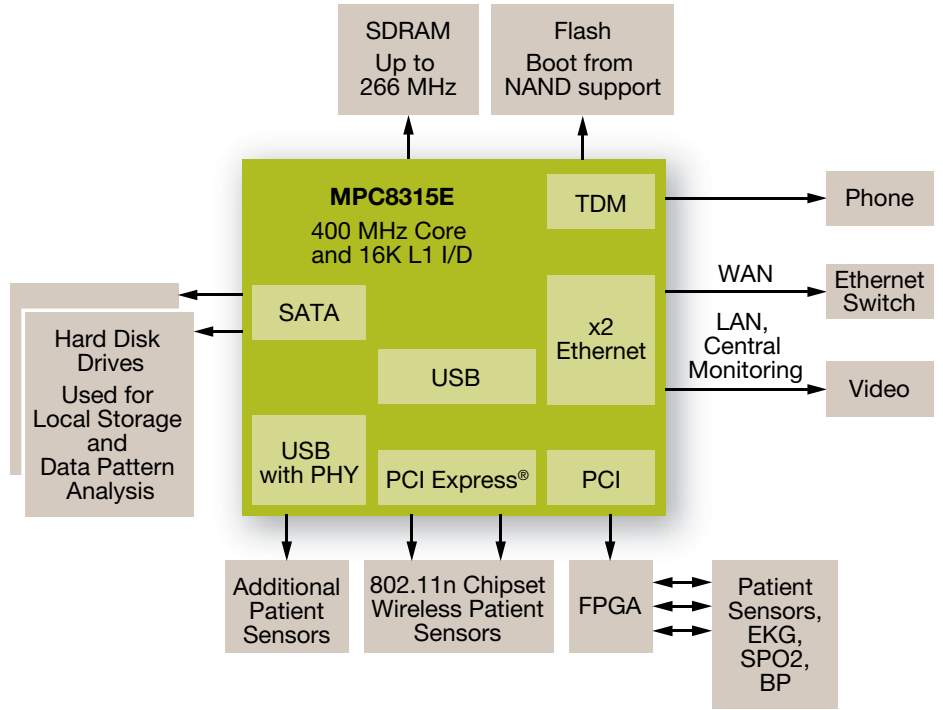

Freescale technology



Applications

- Diagnostic Equipment
- Patient Monitoring
- Networking for Assisted Surgery
- Patient Ethernet Access



Consumer/SOHO

The rapid growth of personal and premium content in and around the home has created the need for multi-service residential gateways, digital media servers and network attached storage devices that can handle feature-rich applications in a secure environment. As consumers download and play music, compete in online games and create and share photos and videos, their home equipment must enable a secure, powerful and seamless user experience.

The widespread availability of broadband Internet access has made the Internet a larger part of how consumers access media. Consumers are looking for ways to remain connected and get access to their multimedia content anytime and anywhere. One such broadband wireless technology that has the potential to overcome this is WiMAX. The combination of wireless Internet access anytime, anywhere for the mass of unconnected consumer electronics devices brings new opportunities for convenience and real-time immersion in the digital world. The MPC8313E processor provides the capabilities and WiMAX support for customers needing to connect, store and stream content via multiple devices in the home.

Digital Media Server System (MPC8313E)

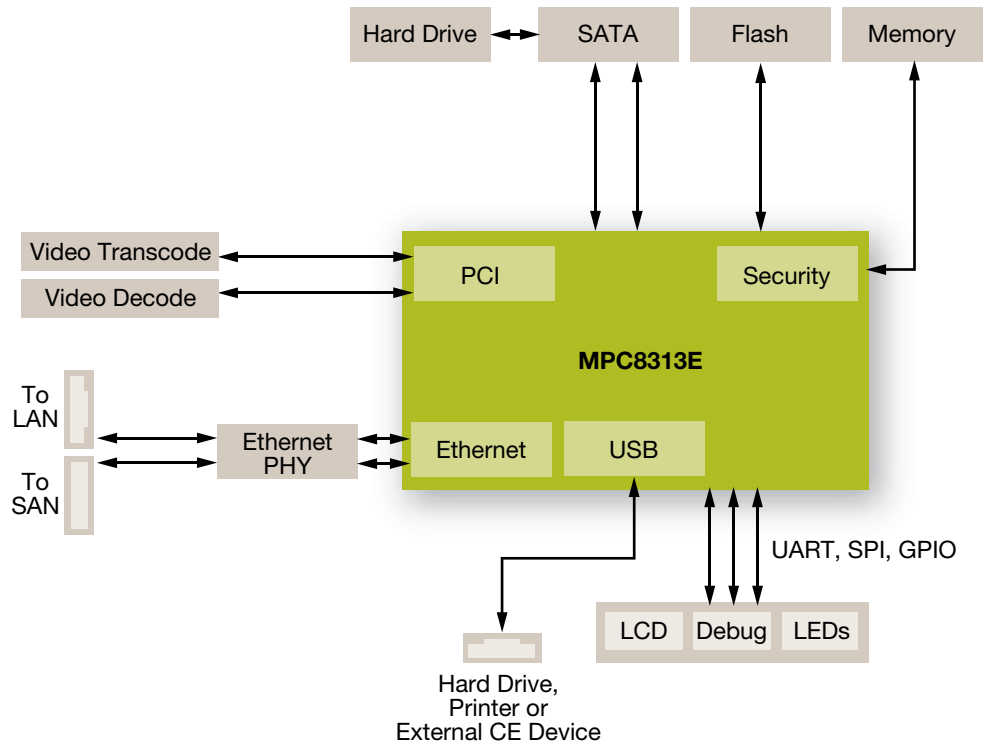

Freescale technology

Features for the Market

- Enables bandwidth to store and backup MPEG and JPEG content
- Enables up to four encrypted HD streams, so multiple TVs can be served simultaneously and seamlessly
- Complies with Digital Living Network Alliance (DLNA) standards to easily manage, view, print and share digital content across multiple devices within the home

Applications

- VoIP Phone
- Residential Gateway
- Digital TV (Network Enabled)
- Security System
- Wireless Router
- Consumer Network Storage Devices

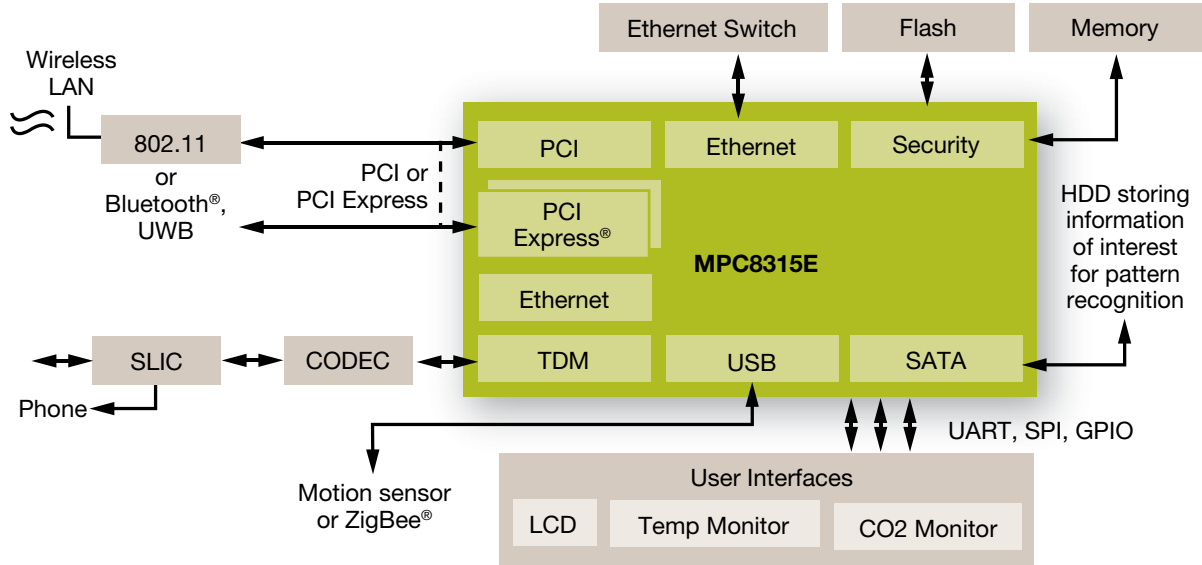

Freescale technology

Building Automation

An intelligent building automation system enables a facilities manager to better manage resources, improve building safety and reduce energy costs. With device networking technology, an intelligent building will allow managers to control virtually every system from a central location.

Given that thousands of buildings are equipped with separate lighting, security, heating, ventilation and air conditioning systems, there is a strong demand for sophisticated controls to incorporate these complex applications. Automation and integration of all equipment functions represent the greatest area of advancement within the building technology arena. Interest is growing for building automation systems as the benefits of reduced resource consumption, increased safety and security and enhanced occupant comfort are realized by end users.

The MPC831x family can connect electronic devices (including security, HVAC, lighting, elevators and safety systems) into a single, efficient building management network.

Features for the Market

- Designed to allow new communication-intensive features, that were previously impossible with a single integrated chip, to be added



- With integrated Ethernet and USB, the MPC8313E is engineered to seamlessly communicate across a variety of protocols
- High-performance core (700+ MIPS) with FPU and MMU
- Integrated dual Ethernet controller
- Hardware encryption acceleration
- PCI expandable
- Serial communications
- -40° to +105°C temperature range

Applications

- Elevator Control
- Fire and Safety Systems
- Remote Meter Reading Aggregator
- HVAC Systems

Storage

Nearly all organizations today are facing record data growth, making storage a front-and-center issue for companies worldwide. And it's spreading to the home market. With storage costs coming down and pressure from tech savvy consumers for integrated homes, the demand for storage devices that are easily deployed and highly integrated is increasing.

Freescale offers a broad portfolio of embedded processor solutions for three market areas: storage area network (SAN), network attached storage (NAS) and digital media server (DMS). These solutions range from high-performance host processors to cost-optimized SoC architectures with integrated redundant array of independent drives (RAID) engines and serial advanced technology attachment (SATA) interfaces.

Features for the Market

- Virtualization support and management control
- Offload RAID ASICx, TCP/IP, or ISCI protocols
- Ability to access, store and stream digital content
- SATA small footprint, affordable to deploy

MPC8315E Consumer NAS Application

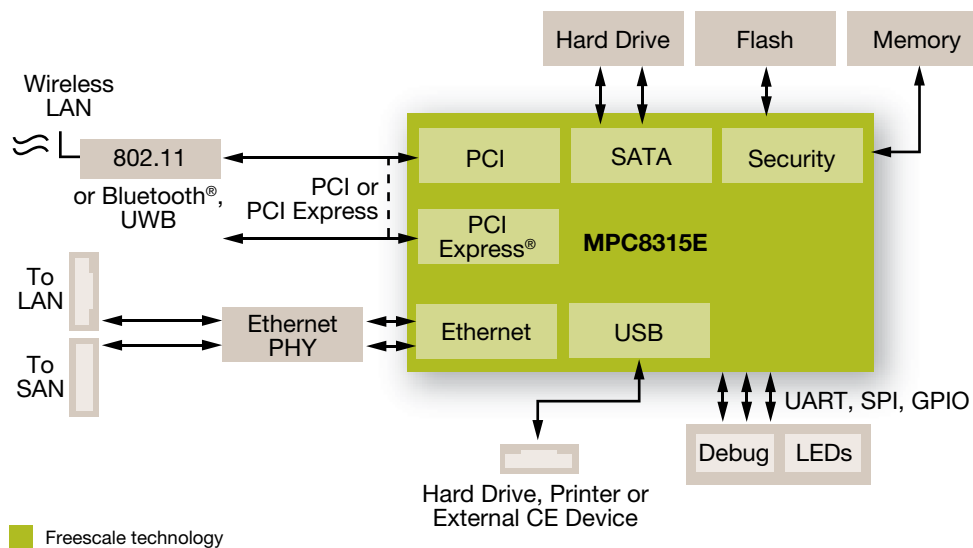

Applications

- Network Attached Storage (NAS)
- Storage Area Network (SAN)
- Digital Media System (DMS)

	MPC8313E	MPC8315E	MPC8314E
CPU Frequency (MHz)	266 to 400	266 to 400	266 to 400
MIPs	510-840	510-840	510-840
Cache (I/D)	16K/16K	16K/16K	16K/16K
DDR2 Controller	1 x 16-/32-bit	1 x 16-/32-bit	1 x 16-/32-bit
DDR2 Frequency (MHz)	333	266	266
PCI	1 32-bit 2.3	1 32-bit 2.3	1 32-bit 2.3
PCI Express®	N	2-x1	2-x1
USB	High-Speed 2.0 w/PHY	High-Speed 2.0 w/PHY	High-Speed 2.0 w/PHY
SATA	N	2x 2.0 w/PHY	N
Security Core	Y	Y	Y
10/100/1000 Ethernet	2 SGMII, RGMII, RTBI, (R)MII	2 SGMII, RGMII, RTBI, (R)MII	2 SGMII, RGMII, RTBI, (R)MII
FPU	Yes	Yes	Yes
UART	Dual	Dual	Dual
I ² C	Dual	Single	Single
SPI	Single	Single	Single
Package	516 Te PBGA II	620 Te PBGA	620 Te PBGA
Estimated Max Power	<2W	<2W	<2W
Protocol Support	IEEE® 1588	IEEE 1588	IEEE 1588



The MPC8313E-RDB ships with Linux® V2.6 with drivers for SATA, 4-port Gigabit Ethernet switch (Vitesse), USB, IEEE 1588 and power management. The board is supported by CodeWarrior V8.8, Wind River, Green Hills and MontaVista development environments.

Ecosystem Support

- IXXAT: IEEE 1588
- Kenati: Residential Gateway
- Mediabolic: Digital Media Server
- Mocana: Security Software Stacks
- Ralink: Wireless

The MPC8315E-RDB ships with a Linux V2.6 board support package (BSP) and is supported by CodeWarrior V8.8, Wind River, Green Hills and MontaVista.

Ecosystem Support

- Axentra: Residential Gateway
- FalconStor: Storage
- Mediabolic: Digital Media Server
- Mocana: Security Software Stacks
- Ralink: Wireless

MPC8313E-RDB Block Diagram

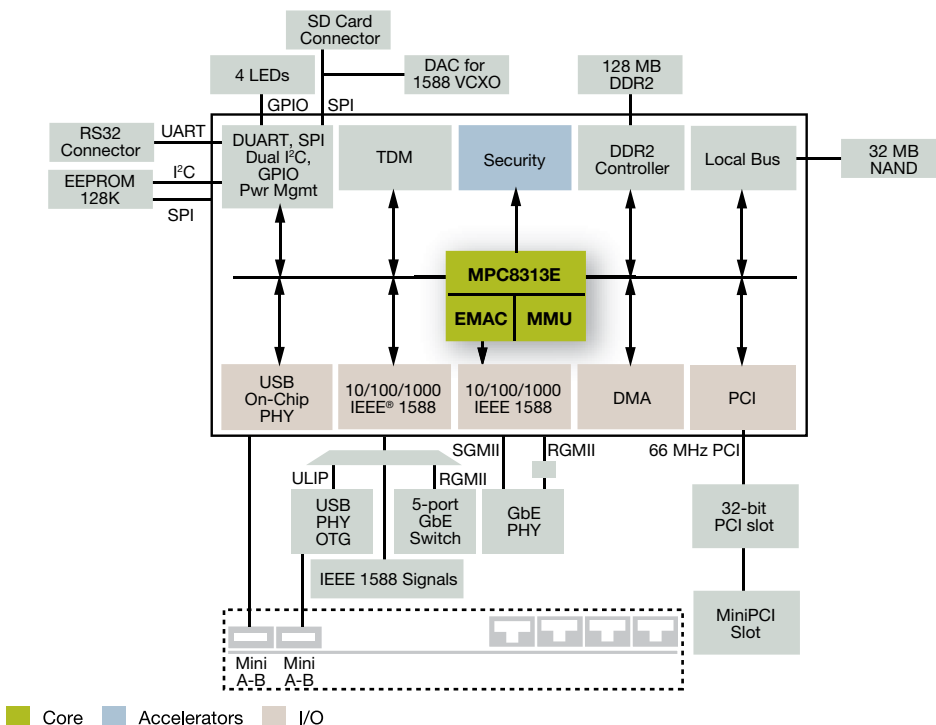

■ Core ■ Accelerators ■ I/O

MPC8315E-RDB Block Diagram

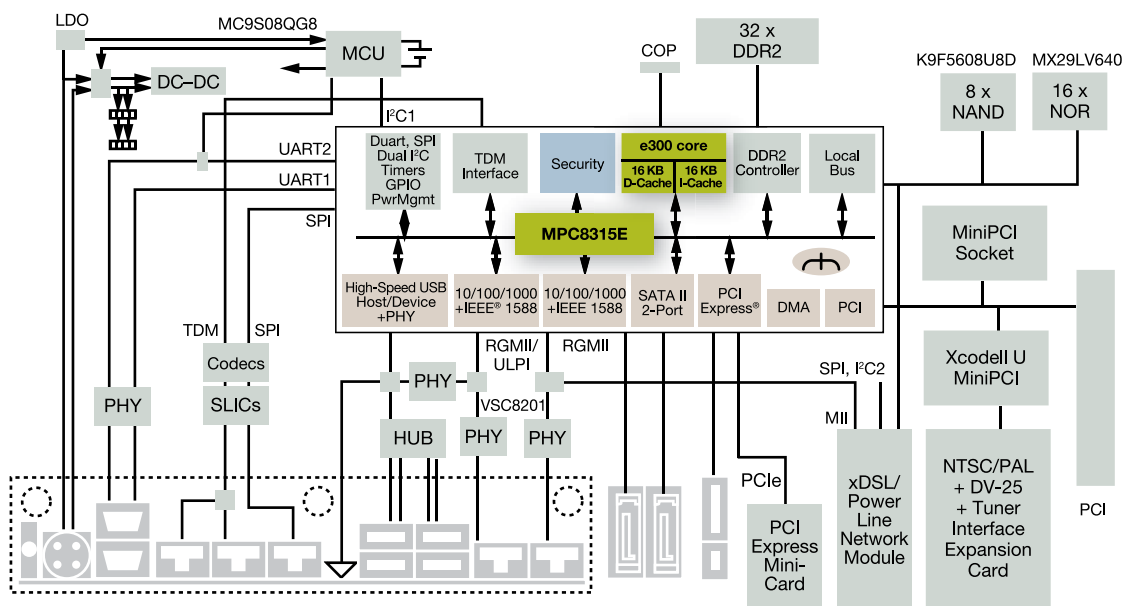

■ Core ■ Accelerators ■ I/O

Learn More: For current information about Freescale products, please visit www.freescale.com.



Freescale and the Freescale logo are trademarks or registered trademarks of Freescale Semiconductor, Inc. in the U.S. and other countries. All other product or service names are the property of their respective owners. The Power Architecture and Power.org word marks and the Power and Power.org logos and related marks are trademarks and service marks licensed by Power.org. ARM is the registered trademark of ARM Limited. ARM 1588 is the trademark of ARM Limited. © Freescale Semiconductor, Inc. 2008

Document Number: MPC831XQRG
REV 0

