



SPI to I²C-Bus Bridge

SC18IS604

Last Updated: Oct 13, 2023

SC18IS604 is designed to serve as an interface between the standard SPI of a host (microcontroller, microprocessor, chip set, etc.) and the serial I²C-bus. This allows the host to communicate directly with other I²C-bus devices. SC18IS604 can operate as an I²C-bus controller-transmitter or controller-receiver. SC18IS604 controls all the I²C-bus specific sequences, protocol, arbitration and timing.

SC18IS604 is a functional replacement for SC18IS600 with exception of: new pinout, transmit and receive buffer of 255 bytes vs 96 bytes, three instead of four GPIOs but no longer with quasi bidirectional mode, operating supply voltage lower level lowered to 1.71 V vs 2.4 V and temperature range of -40 to 105 °C vs -40 to 85 °C.

SC18IS604 Block Diagram Block Diagram

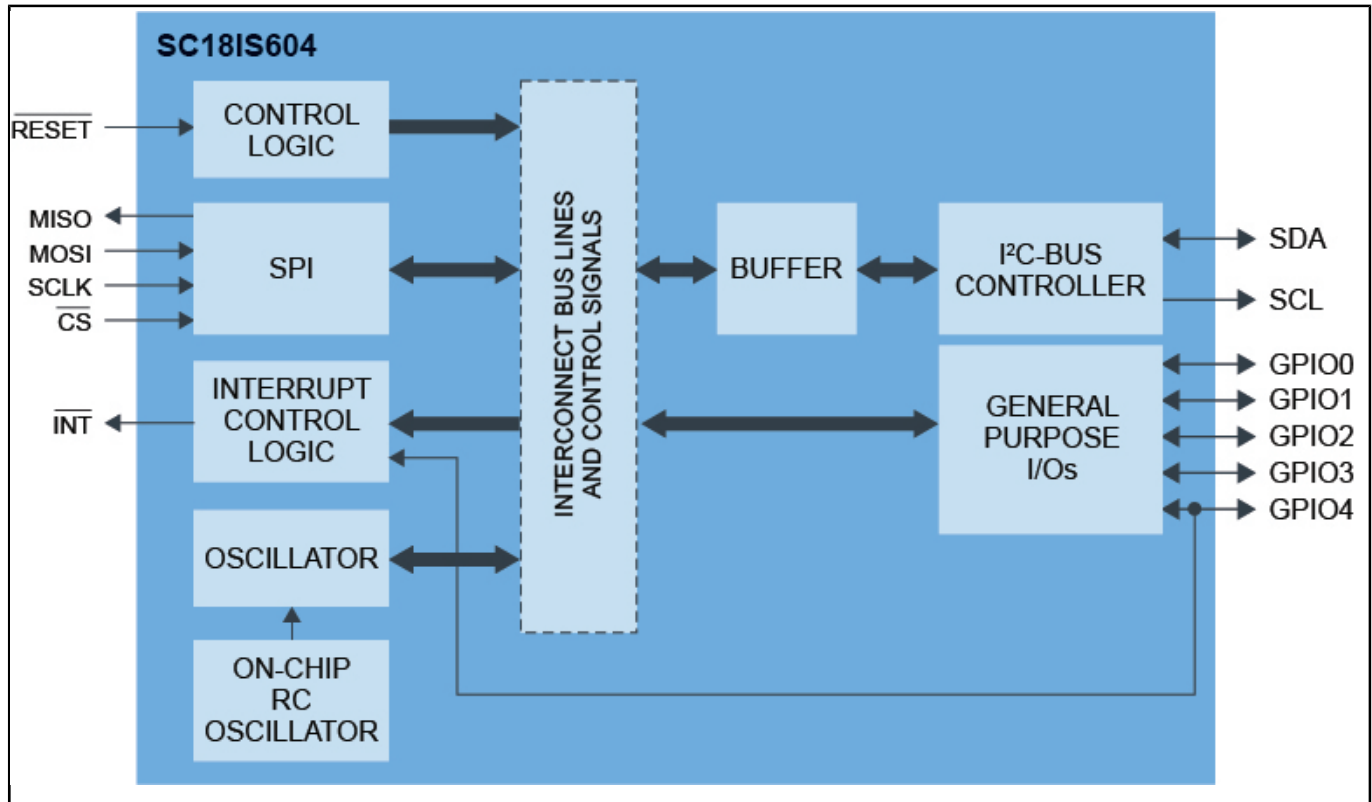

View additional information for [SPI to I²C-Bus Bridge](#).

Note: The information on this document is subject to change without notice.

www.nxp.com

NXP and the NXP logo are trademarks of NXP B.V. All other product or service names are the property of their respective owners. The related technology may be protected by any or all of patents, copyrights, designs and trade secrets. All rights reserved. © 2024 NXP B.V.