



Arm7™ with 512 kB flash, 58 kB SRAM, Ethernet, USB 2.0 Device, CAN, SD/MMC, and 10-bit ADC

LPC2368FET100

Not Recommended for New Designs

This page contains information on a product that is not recommended for new designs.

Last Updated: Apr 8, 2022

The LPC2368FET100 is a Arm7 microcontroller for embedded applications featuring a high level of integration and low power consumption at frequencies of 72 MHz. Features include up to 256 kB of flash memory, up to 58 kB of RAM, Ethernet MAC, USB Device/Host/OTG, DMA controller, SD/MMC, 4 UARTs, 2 CAN channels, 3 SSP/SPI, 3 I2C, I2S, 8-channel 10-bit ADC, 10-bit DAC, 2 PWM, 4 general purpose timers, low power Real-Time Clock with separate battery supply, and up to 70 general purpose I/O pins. The LPC23xx are pin-compatible to the LPC176x Cortex-M3 series.

Block diagram: LPC2364FBD100, LPC2364FET100, LPC2364HBD100, LPC2365FBD100, LPC2366FBD100, LPC2367FBD100, LPC2368FBD100, LPC2368FET100 Block Diagram

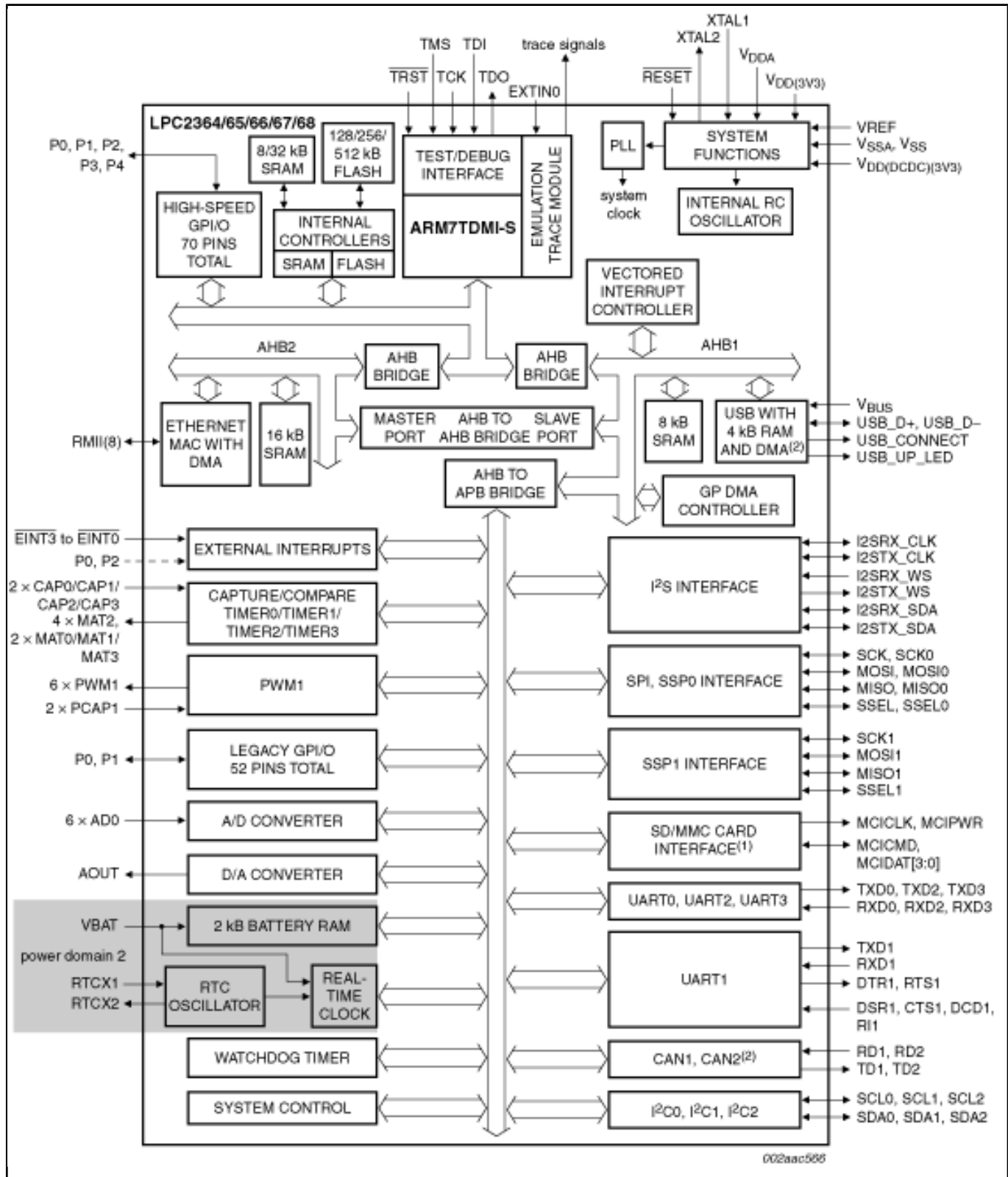

View additional information for [Arm7™ with 512 kB flash, 58 kB SRAM, Ethernet, USB 2.0 Device, CAN, SD/MMC, and 10-bit ADC.](#)

Note: The information on this document is subject to change without notice.

www.nxp.com

NXP and the NXP logo are trademarks of NXP B.V. All other product or service names are the property of their respective owners. The related technology may be protected by any or all of patents, copyrights, designs and trade secrets. All rights reserved. © 2024 NXP B.V.