



# DSI3/SPI Automotive Safety Digital Accelerometer

## FXLS90

Last Updated: Jul 25, 2023

The FXLS90 family is the latest generation of airbag crash sensors from NXP.

The devices are designed using NXP proprietary UMEMS sensing technology combined with a signal conditioning ASIC in a QFN 4 x 4 x 1.45 mm package.

The devices feature a user selectable DSI3 interface, 32-bit SPI interface. They can measure acceleration in single or dual independent axis configuration from +/-15.5 g to +/-500 g. The embedded DSP provides fully programmable digital high and low pass filtering.

The FXLS90 family is fully AEC-Q100 qualified up to 125# operating temperature and is compliant with the AK LV 27 requirements. The package has wettable flanks for solder joint inspection. FXLS90 products have been developed following ISO26262 2018 edition and can be used in up to ASIL D system.

For additional information and sample availability, contact your local [sales office](#).

## FXSL9x Single Axis internal Block Diagram Block Diagram

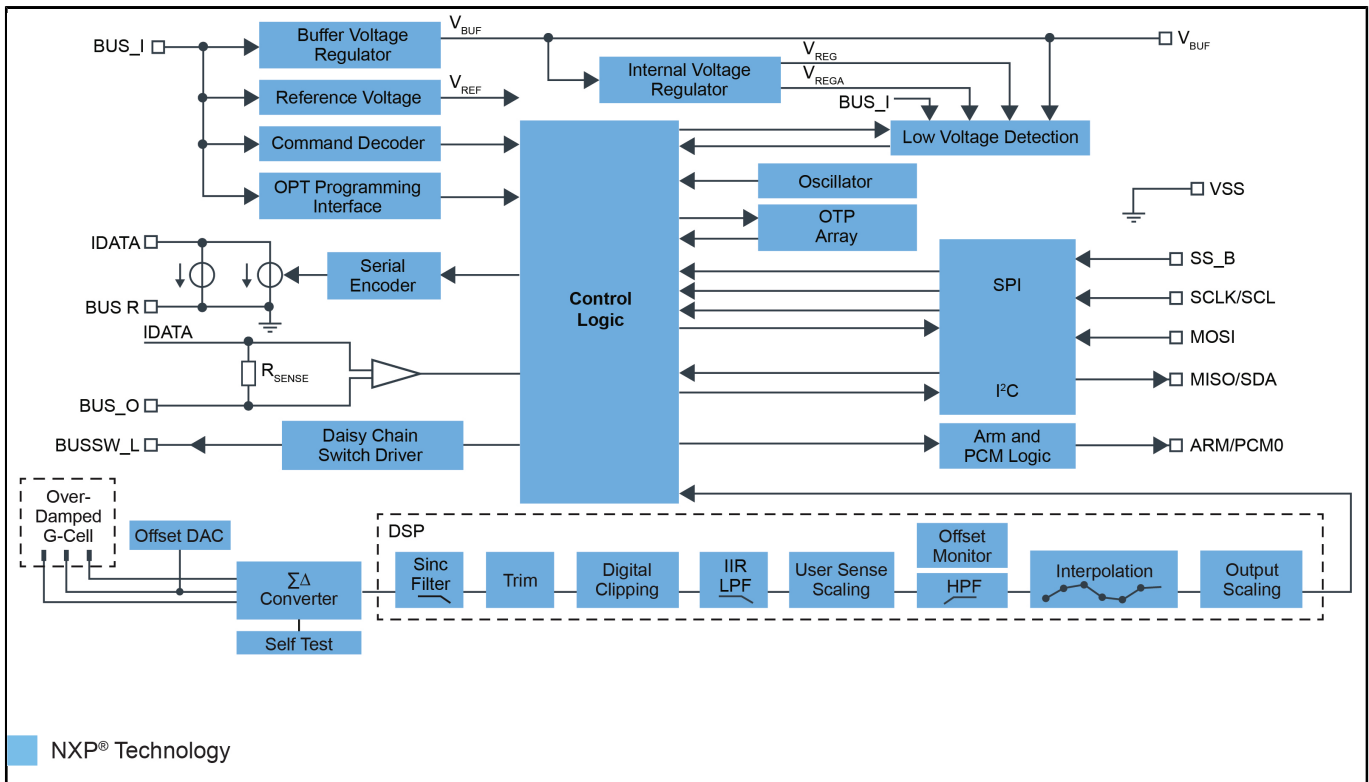

## FXLS90 Application Diagram Block Diagram

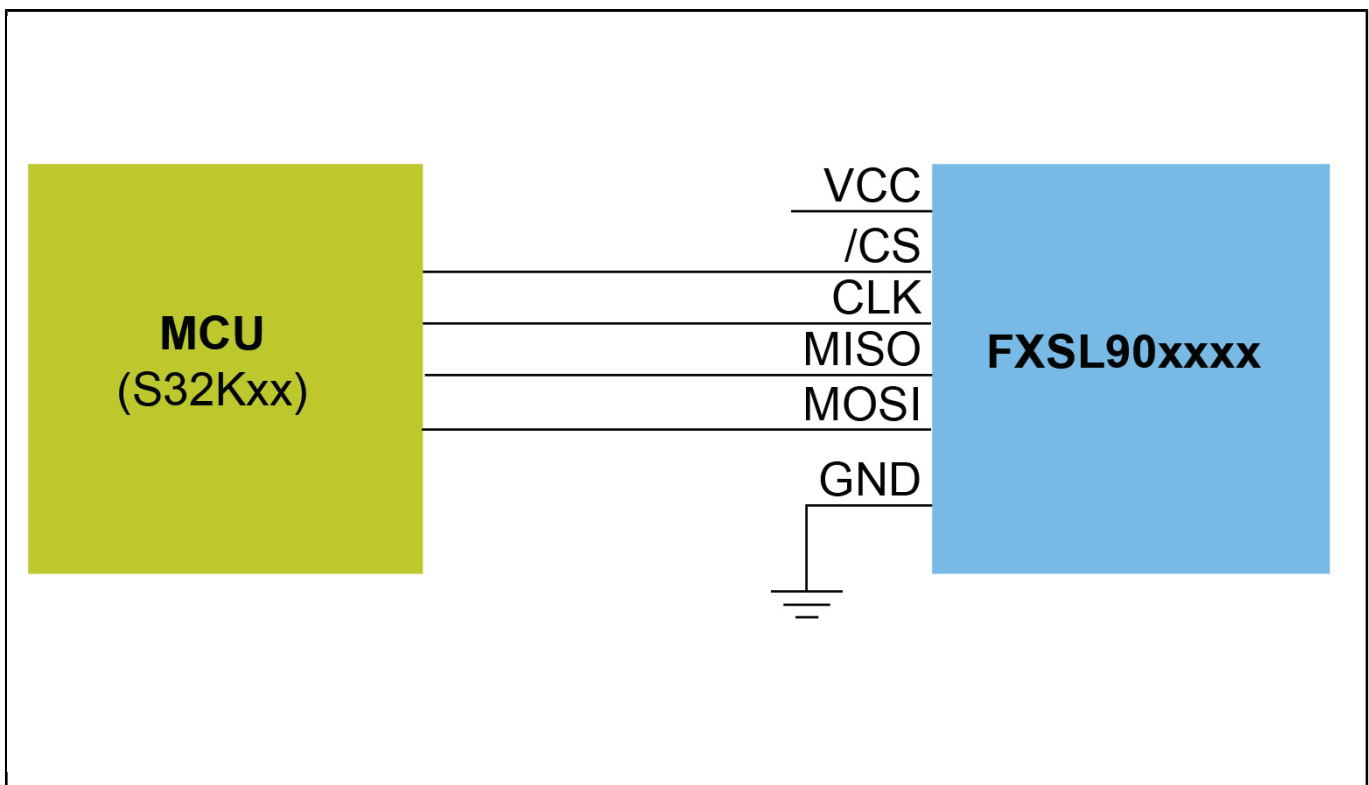

## FXLS90 DSI3 Application Diagram Block Diagram

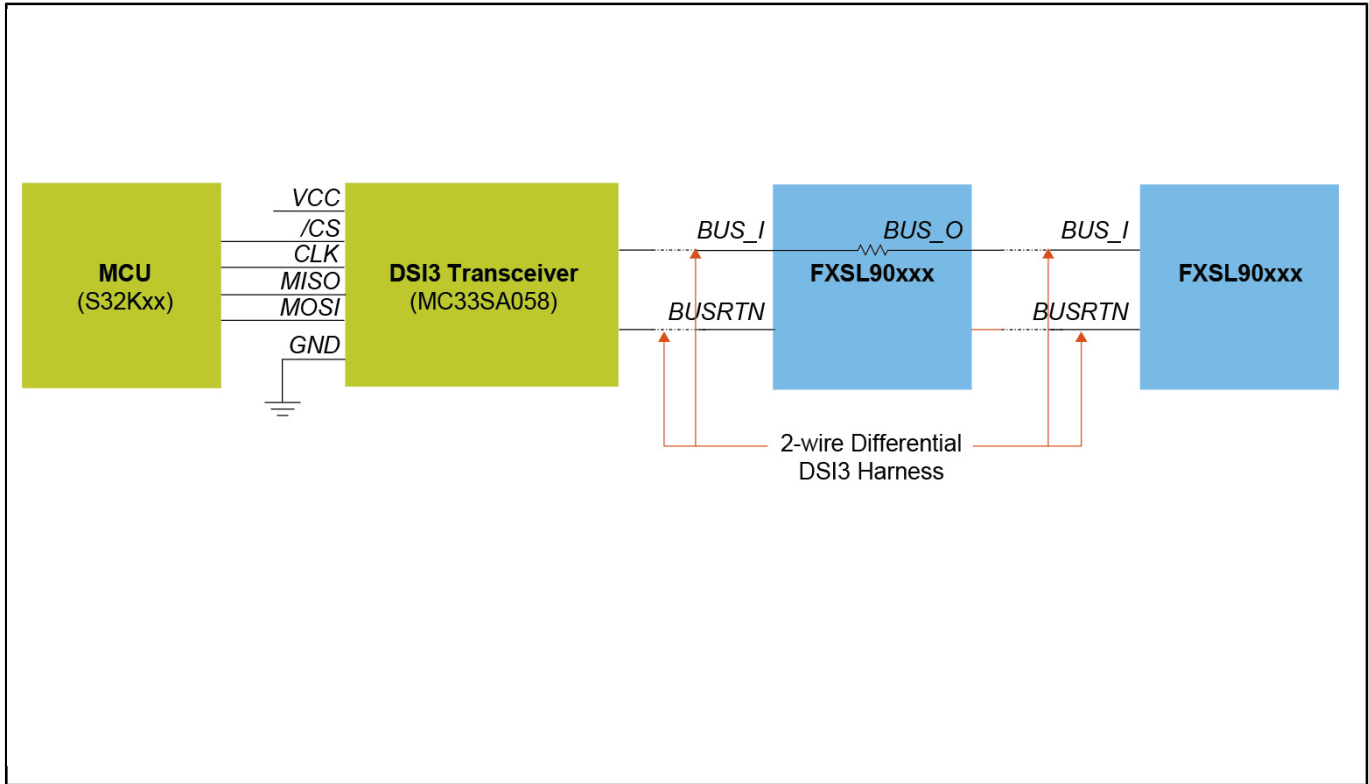

View additional information for [DSI3/SPI Automotive Safety Digital Accelerometer](#).

**Note:** The information on this document is subject to change without notice.

[www.nxp.com](http://www.nxp.com)

NXP and the NXP logo are trademarks of NXP B.V. All other product or service names are the property of their respective owners. The related technology may be protected by any or all of patents, copyrights, designs and trade secrets. All rights reserved. © 2024 NXP B.V.